

TRI-LEG GLYCOL FEED SYSTEMS SYSTEM SPECIFICATIONS

WSS161004.D 01/24



DESCRIPTION

1.0) **AUTOMATIC GLYCOL FEED PACKAGE:** Tri-leg glycol feed systems shall consist of a polyethylene tank, polyethylene lid, tri-leg carbon steel frame, NEMA 4X control panel, low level float switch, 1/4HP open motor bronze rotary vane pump with internal relief valve, pressure switch, relief valve, check valve, Schedule 40 carbon steel and black iron plumbing and high temperature rubber hoses.

MATERIALS

2.0) **TANK AND FRAME:** Polyethylene tank shall be industrial grade with a nominal wall thickness of 1/8". Tank stand frame shall be constructed of carbon steel with bracing for plumbing and control panel. Tank frame shall have 14ga pump mount shelf and be coated with water based enamel paint. (Check size below.)

- 15 Gallon tank and stand
- 30 Gallon tank and stand
- 50 Gallon tank and stand
- 100 Gallon tank and stand

2.1) **PUMP:** Pump shall be close-coupled with internal pressure relief valve. Standard pump will be capable of 1.6 GPM @ 100 PSI. Pump motor is 1/4HP, 110/120 VAC, 1 phase, 60 hertz, open drip proof type and will be wired to control panel. (Options below.)

- 1/2HP with an output of 3.6 GPM @ 100 PSI
- Dual pumps, discharge manifold and suction manifold, (only applicable on 50 and 100 gallon systems.)

2.2) **PRESSURE SWITCH:** Pressure switch shall be designed for pressures as indicated below. Pressure switch will be prewired to the control panel to turn the pump on and off based on rising and falling pressure settings. (Check one below.)

- Code 1 (10-45 PSI cut-in, 20-60 PSI cut-out, 10-30 PSI pressure differential)
- Code 2 (40-80 PSI cut-in, 65-100 PSI cut-out, 20-40 PSI pressure differential)
- Code 3 (3-10 PSI cut-in, 9-30 PSI cut-out, 6-20 PSI pressure differential)
- Code D* (0-149 PSI cut-in, 1-150 PSI cut-out, 1-149 PSI pressure differential)
- Code X (no pressure switch)

**D Represents change Digital Glycol Feed System*

2.3) **CONTROL PANEL:** Polycarbonate NEMA 4X lockable control panel shall be of ample size for equipment needs and servicing of electrical components. All exterior components shall be rated NEMA 4X and installed per manufacturer's instructions. Wiring and wiring diagram shall be color-coded for easy trouble shooting. All internal wire shall be 16ga minimum. Controls are, but not limited to, main power switch and indicator light, pump hand/off/auto switch and indicator light and red low-level indicator light.

2.4) **PRESSURE RELIEF VALVE:** Pressure relief valve shall be Conbraco model 16-501-01, constructed of bronze with a nitrile diaphragm.

2.5) **CHECK VALVE:** Back flow check valve shall be a true union design with soft seat cone, PVC construction, and EPDM seals for positive seal.

2.6) **LOW LEVEL SWITCH:** Polypropylene low level switch shall be interlocked with pump feed and low level indicator. Low level will stop all pump operations when level falls below the factory set point.

TRI-LEG GLYCOL FEED SYSTEMS SYSTEM SPECIFICATIONS

WSS161004.D 01/24



2.7) **OPTIONAL FEATURES:** (Check all that apply below.)

- AUDIBLE ALARM:** Audible alarm shall be 95 decibel @ 10ft with silence switch that will sound on low level, (Option B).
- LOW LEVEL DRY CONTACT:** Dry contact shall be SPST NO switch that is wired to level switch for control room signal, (Option C).
- EXPANSION TANK:** 4.5 gallon expansion tank with adjustable pressure reducing valve, Max. Pressure: 70 PSI (Option ET).
- HIGH LEVEL DRY CONTACT:** Dry contact shall be SPST NO switch that is wired to level switch for control room signal, (Option HC).
- HINGED COVER:** Shoebox type lid shall be 1/3 the diameter hinged with 304 stainless steel piano hinge and 316 stainless steel rivets, (Option HN).
- MIXER:** TEFC stand mounted mixer with On-Off switch. 1/20HP for units less than or equal to 55 gallon, 1/4HP for units greater than 55 gallons, (Option MXR).
- TEFC:** Totally Enclosed Fan Cooled pump motor in place of the standard ODP pump, (Option TEFC).
OUTDOOR: Outdoor rated system with a bolted down cover and TEFC pump, (Option OUTDOOR).

- 3.0) **WARRANTY:** Wingert Glycol Feed Systems are warranted against manufacturing defects in material and workmanship for one year from the date of shipment. Applications outside the service for which the product is designed will automatically void any warranty. J.L. Wingert Co. will repair or replace a defective unit when returned to the factory with transportation prepaid. Final determination will be made upon inspection. J.L. Wingert Co. assumes no liability for labor and/or other expenses in making repairs or adjustments. All replacements will be F.O.B. factory. There are no other implied or expressed warranties.

The pump is not manufactured by J.L. Wingert Co. and thus is warranted by the original manufacturer. Repair or replacement is contingent upon inspection and determination by the original manufacturer. Their findings are final and beyond our control.

J.L. WINGERT CO.

Specification Sheet TRI-LEG GLYCOL FEED SYSTEM MODEL TGL[]-E[]-[]

SS161004.E 01/24

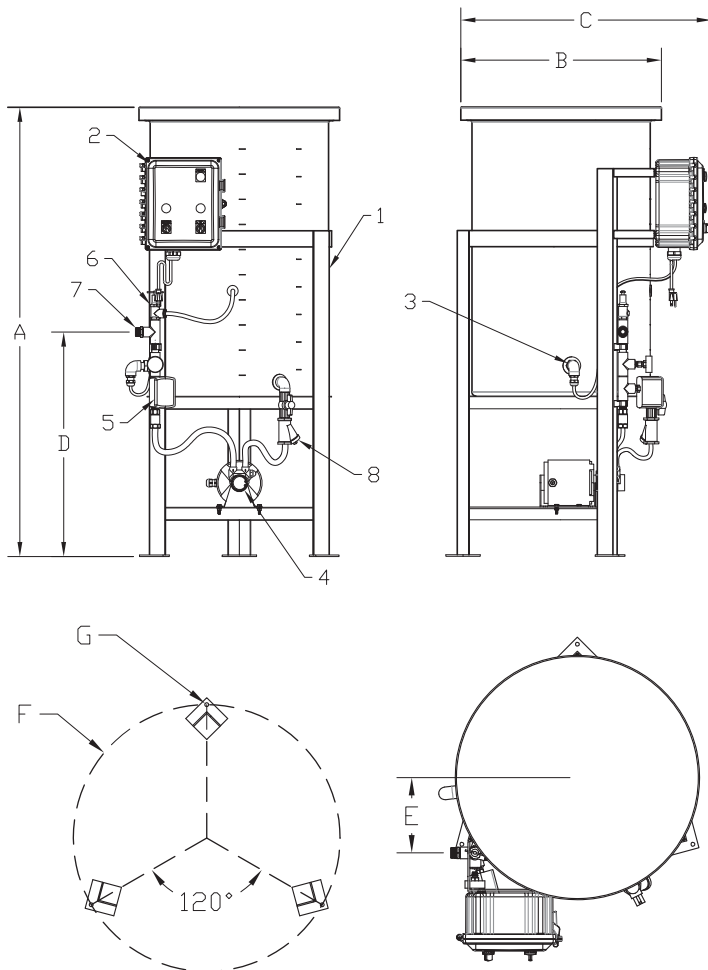

SPECIFICATIONS:

KEY	MODEL	DESCRIPTION
TANK/TANK STAND:		
1	TGL15-E[]-[]	15 Gallon polyethylene tank with cover. Tank is supported and restrained by a carbon steel tank stand. Tank stand is coated with water based enamel paint.
	TGL30-E[]-[]	30 Gallon polyethylene tank with cover. Tank is supported and restrained by a carbon steel tank stand. Tank stand is coated with water based enamel paint.
	TGL50-E[]-[]	50 Gallon polyethylene tank with cover. Tank is supported and restrained by a carbon steel tank stand. Tank stand is coated with water based enamel paint.
	TGL100-E[]-[]	100 Gallon polyethylene tank with cover. Tank is supported and restrained by a carbon steel tank stand. Tank stand is coated with water based enamel paint.
CONTROL PANEL:		
2	ALL	NEMA 4X control panel includes the following: -8ft 115VAC power cord -Main power off-on switch and green LED indicator light -Pump H-O-A switch and green LED indicator light -Red low level LED indicator light -15 Amp slow blow fuse -115VAC Auxiliary low level output
LOW LEVEL SWITCH:		
3	ALL	Polypropylene side entry low level switch with 12 Amp relay.
PUMP:		
4	ALL	1/4HP brass rotary vane pump that provides even flow against pressure. See the Pump Curves on page 2. *Optional 1/2HP brass rotary vane pump (E2)
PRESSURE SWITCH:		
5	ALL	1/4" NPT pressure switch. See Pressure Code on page 2 for cut-in and cut-out values.
PRESSURE RELIEF VALVE:		
6	ALL	20-150 PSI brass pressure relief valve
OUTLET:		
7	ALL	3/4" MNPT
SUCTION ASSEMBLY:		
8	ALL	Black iron fittings, brass isolation ball valve, cast iron Y-Strainer
MAXIMUM PRESSURE:		150 PSI (10.3 BAR)
MAXIMUM TEMPERATURE:		150 °F (65.5 °C)

DIMENSIONS:

	TGL15-E[]-[]	TGL30-E[]-[]	TGL50-E[]-[]	TGL100-E[]-[]
A	42 3/8"	50"	55 7/16"	72 3/16"
B	17 1/8"	20 3/16"	24 3/4"	30 1/4"
C	25 3/8"	27 11/16"	30 15/16"	35 13/16"
D	19 3/4"	27 11/16"	27 11/16"	27 11/16"
E	5 15/16"	6 11/16"	7 5/8"	8 7/8"
F	20 3/16"	23 1/4"	27"	32 1/16"
G	3/8"	3/8"	3/8"	3/8"
SHIPPING DIMENSION	30"x30"x48"	30"x36"x55"	30"x36"x60"	36"x36"x68"
SHIPPING WEIGHT	90 lbs	115 lbs	130 lbs	180 lbs

OPTIONAL FEATURES

-B	95 decibel audible alarm and silence switch
-C	Remote dry contact on low level, (PLC interface)
-ET	Expansion tank, 4.5 gallon with adjustable pressure reducing valve (Max. Pressure: 70 PSI)
-HC	High level float switch with remote dry contact (PLC interface)
-HN	1/3 hinged cover using stainless steel piano hinge with stainless steel hardware
-MXR	TEFC, tank stand mounted mixer and ON/OFF switch
-TEFC	TEFC, (Totally Enclosed Fan Cooled), pump motor
-OUTDOOR	Outdoor rated glycol feed system (TEFC pump, solid cover, cover is bolted to the tank)

Note: All dimensions are +/- 1/8". All weights are approximate. All dimensions are subject to change without notice.

MANUFACTURING: Mixers, Bypass Feeders, Filter Feeders, Bromine Feeders, Sample Coolers, Sludge Traps, Separators, Separator Systems, Tank Stands, Tank Package Systems, Glycol Feed Systems, Coupon Racks, Control Stations, NEMA Enclosures, Custom Packaged Systems and Specialty Welding

1298 N Blue Gum St, Anaheim, CA 92806 | Phone (714) 379-5519 | Fax (714) 379-5549 Northern California Region | Phone (510) 487-5310 | Southwest Region | Phone (602) 470-1015 | Email: customerservice@jllwingert.com

www.jllwingert.com

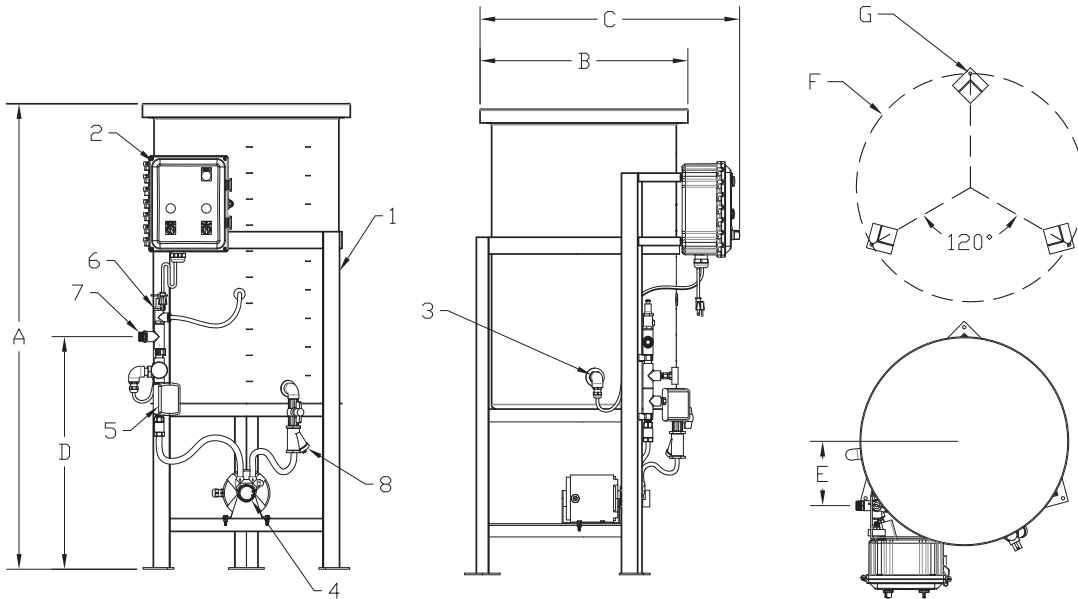

PRESSURE CODE	CUT-IN RANGE (PSI)	CUT-OUT RANGE (PSI)	PRESSURE DIFFERENTIAL (PSI)
1*	10 - 45	20 - 60	10 - 30
2	40 - 80	65 - 100	20 - 40
3	3 - 10	9 - 30	6 - 20
D**	0 - 149	1 - 150	1 - 149
X	No Pressure Switch		

*Code 1 is standard. Code 2 and Code 3 are available at no additional charge.
 **Code D is digital. For output pressure exceeding 100PSI, please consult the factory.

STANDARD MOTOR (E1)		OPTIONAL MOTOR (E2)	
MOTOR DATA		MOTOR DATA	
HP:	1/4	HP:	1/2
MOTOR TYPE:	Split-Phase Carbonator Pump Motor	MOTOR TYPE:	Split-Phase Carbonator Pump Motor
ENCLOSURE:	ODP	ENCLOSURE:	ODP
NEMA FRAME:	48Y	NEMA FRAME:	48Y
VOLTAGE:	115 VAC	VOLTAGE:	100 - 120 / 200 - 240 VAC
PHASE:	1	PHASE:	1
FULL LOAD AMPS:	5	FULL LOAD AMPS:	7.1 - 7.2 / 3.4 - 3.6
THERMAL PROTECTION:	YES	THERMAL PROTECTION:	YES
INSULATION CLASS:	B	INSULATION CLASS:	B
SERVICE FACTOR:	1	SERVICE FACTOR:	1
NAMEPLATE RPM:	1725	NAMEPLATE RPM:	1725

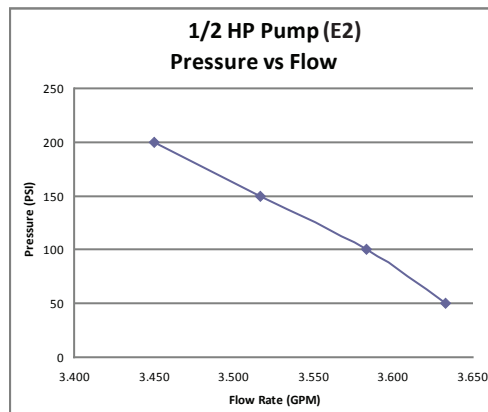
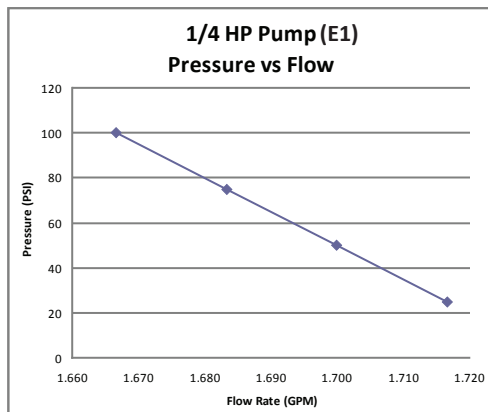

Note: All dimensions are +/- 1/8". All weights are approximate. All dimensions are subject to change without notice.