

J.L. WINGERT CO.

Specification Sheet DUAL TRI-LEG GLYCOL FEED SYSTEM MODEL TGL[]-2E[]-[]

SS161008.C 01/24

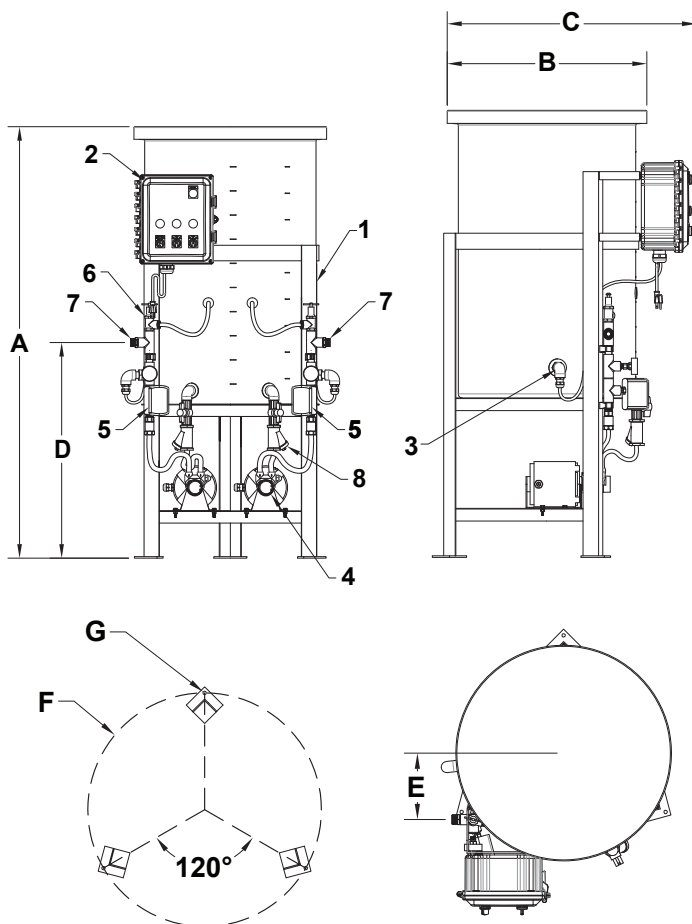

SPECIFICATIONS:

KEY	MODEL	MODEL
TANK/TANK STAND:		
1	TGL50-2E[]-[]	50 Gallon polyethylene tank with cover. Tank is supported and restrained by a carbon steel tank stand. Tank stand is coated with water based enamel paint.
	TGL100-2E[]-[]	100 Gallon polyethylene tank with cover. Tank is supported and restrained by a carbon steel tank stand. Tank stand is coated with water based enamel paint.
CONTROL PANEL:		
2	ALL	NEMA 4X control panel includes the following: -8ft 115VAC power cord -Main power off-on switch and green LED indicator light -Pump 1 H-O-A Switch and Green LED Indicator Light -Pump 2 H-O-A Switch and Green LED Indicator Light -Red low level LED indicator light -15 Amp slow blow fuse -115VAC Auxiliary low level output
LOW LEVEL SWITCH:		
3	ALL	Polypropylene side entry low level switch with 12 Amp relay.
PUMP:		
4	ALL	1/4HP brass rotary vane pump that provides even flow against pressure (Qty: 2ea). See the Pump Curves on page 2. *Optional 1/2HP brass rotary vane pump (E2)
PRESSURE SWITCH:		
5	ALL	1/4" NPT pressure switch (Qty: 2ea). See Pressure Code on page 2 for cut-in and cut-out values.
PRESSURE RELIEF VALVE:		
6	ALL	20-150 PSI brass pressure relief valve (Qty: 2ea)
OUTLET:		
7	ALL	3/4" MNPT (Qty: 2ea)
SUCTION ASSEMBLY:		
8	ALL	Black iron fittings, brass isolation ball valve, cast iron Y-Strainer (Qty: 2ea)
MAXIMUM PRESSURE:		150 PSI (10.3 BAR)
MAXIMUM TEMPERATURE:		150°F (65.5°C)

DIMENSIONS:

	TGL50-2E[]-[]	TGL100-2E[]-[]
A	55 7/16"	72 3/16"
B	24 3/4"	30 1/4"
C	30 15/16"	35 13/16"
D	27 11/6"	27 11/16"
E	7 5/8"	8 7/8"
F	27"	32 1/16"
G	3/8"	3/8"
SHIPPING DIMENSION	30"x36"x60"	36"x36"x68"
SHIPPING WEIGHT	152 lbs	202 lbs

OPTIONAL FEATURES

-B	95 decibel audible alarm and silence switch
-C	Remote dry contact on low level, (PLC interface)
-ET	Expansion tank, 4.5 gallon with adjustable pressure reducing valve (Max. Pressure: 70 PSI)
-HC	High level float switch with remote dry contact (PLC interface)
-HN	1/3 hinged cover using stainless steel piano hinge with stainless steel hardware
-MXR	TEFC, tank stand mounted mixer and ON/OFF switch
-TEFC	TEFC, (Totally Enclosed Fan Cooled), pump motor
-OUTDOOR	Outdoor rated glycol feed system (TEFC pump, solid cover, cover is bolted to the tank)

Note: All dimensions are +/- 1/8". All weights are approximate. All dimensions are subject to change without notice.

MANUFACTURING: Mixers, Bypass Feeders, Filter Feeders, Bromine Feeders, Sample Coolers, Sludge Traps, Separators, Separator Systems, Tank Stands, Tank Package Systems, Glycol Feed Systems, Coupon Racks, Control Stations, NEMA Enclosures, Custom Packaged Systems and Specialty Welding

1298 N Blue Gum St, Anaheim, CA 92806 | Phone (714) 379-5519 | Fax (714) 379-5549 Northern California Region | Phone (510) 487-5310 | Southwest Region | Phone (602) 470-1015 | Email: customerservice@jllwingert.com

www.jllwingert.com

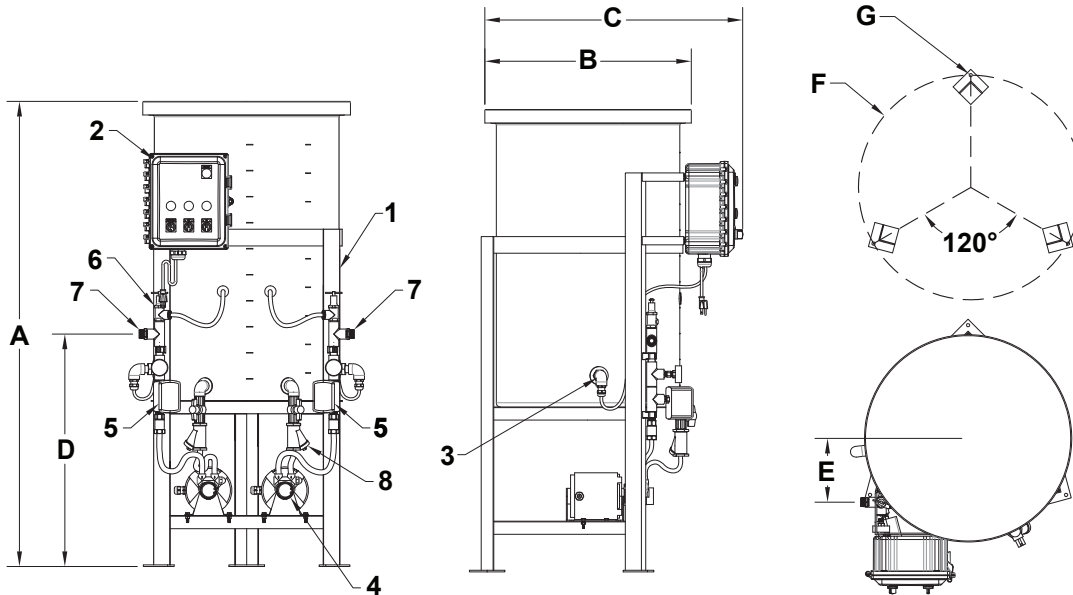

PRESSURE CODE	CUT-IN RANGE (PSI)	CUT-OUT RANGE (PSI)	PRESSURE DIFFERENTIAL (PSI)
1*	10 - 45	20 - 60	10 - 30
2	40 - 80	65 - 100	20 - 40
3	3 - 10	9 - 30	6 - 20
D**	0 - 149	1 - 150	1 - 149
X	No Pressure Switch		

*Code 1 is standard. Code 2 and Code 3 are available at no charge
 **Code D is the Digital.

STANDARD MOTOR (E1)		OPTIONAL MOTOR (E2)	
MOTOR DATA		MOTOR DATA	
HP:	1/4	HP:	1/2
MOTOR TYPE:	Split-Phase Carbonator Pump Motor	MOTOR TYPE:	Split-Phase Carbonator Pump Motor
ENCLOSURE:	ODP	ENCLOSURE:	ODP
NEMA FRAME:	48Y	NEMA FRAME:	48Y
VOLTAGE:	115 VAC	VOLTAGE:	100 - 120 / 200 - 240 VAC
PHASE:	1	PHASE:	1
FULL LOAD AMPS:	5	FULL LOAD AMPS:	7.1 - 7.3 / 3.4 - 3.6
THERMAL PROTECTION:	YES	THERMAL PROTECTION:	YES
INSULATION CLASS:	B	INSULATION CLASS:	B
SERVICE FACTOR:	1	SERVICE FACTOR:	1
NAMEPLATE RPM:	1725	NAMEPLATE RPM:	1725

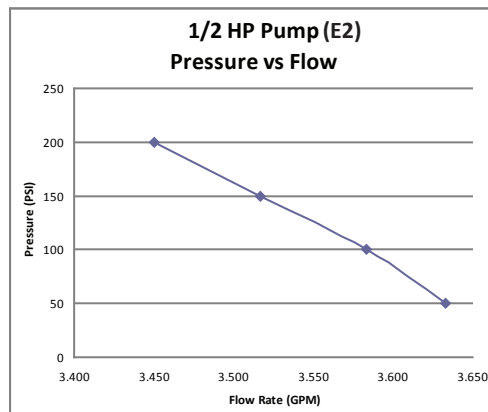
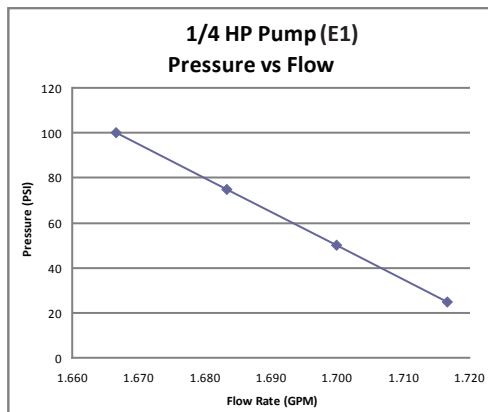

Note: All dimensions are +/- 1/8". All weights are approximate. All dimensions are subject to change without notice.