

J.L. WINGERT CO.

Specification Sheet SIGHT TUBE ASSEMBLY OPTION II

SS102210.C 02/17

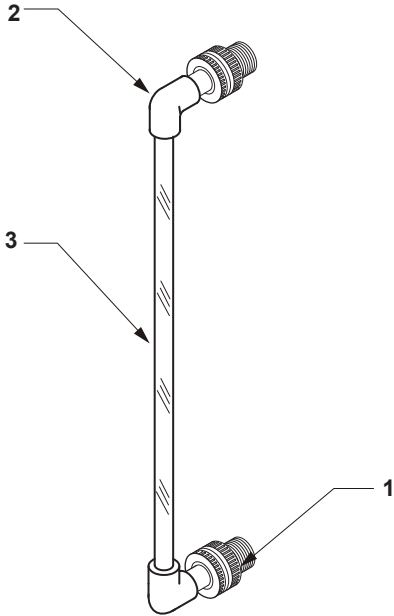

SPECIFICATIONS

KEY	PART	DESCRIPTION
1	II	ADAPTER: Constructed of 1/2" gray Sch. 80 PVC with both threaded and slip connections
2		ELBOW: Threaded 1/2" NPT Sch. 80 PVC
3		CLEAR PVC TUBE: Constructed of clear Sch. 80 PVC

TYPICAL USES

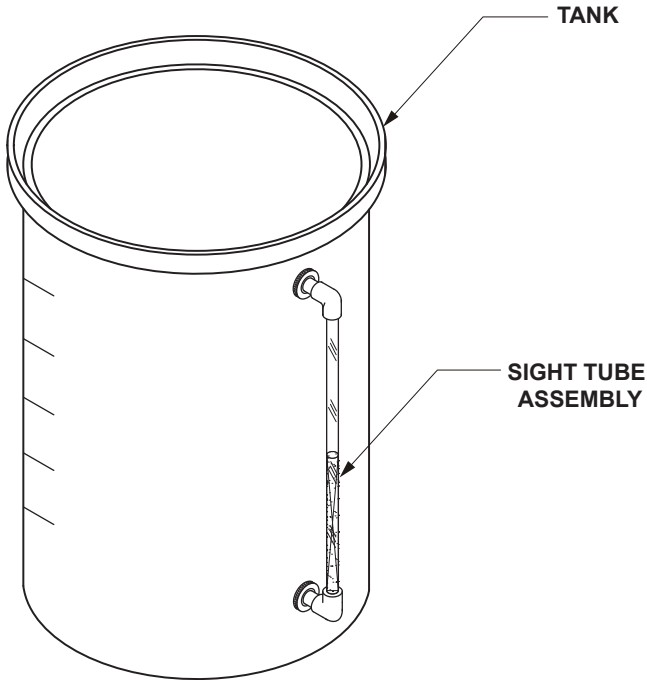

Note: All dimensions are +/- 1/8". All weights are approximate. All dimensions are subject to change without notice.