

# J.L. WINGERT CO.

## Specification Sheet HIGH-LOW LEVEL CONTROLLER OPTION KK

SS102209.D 02/17

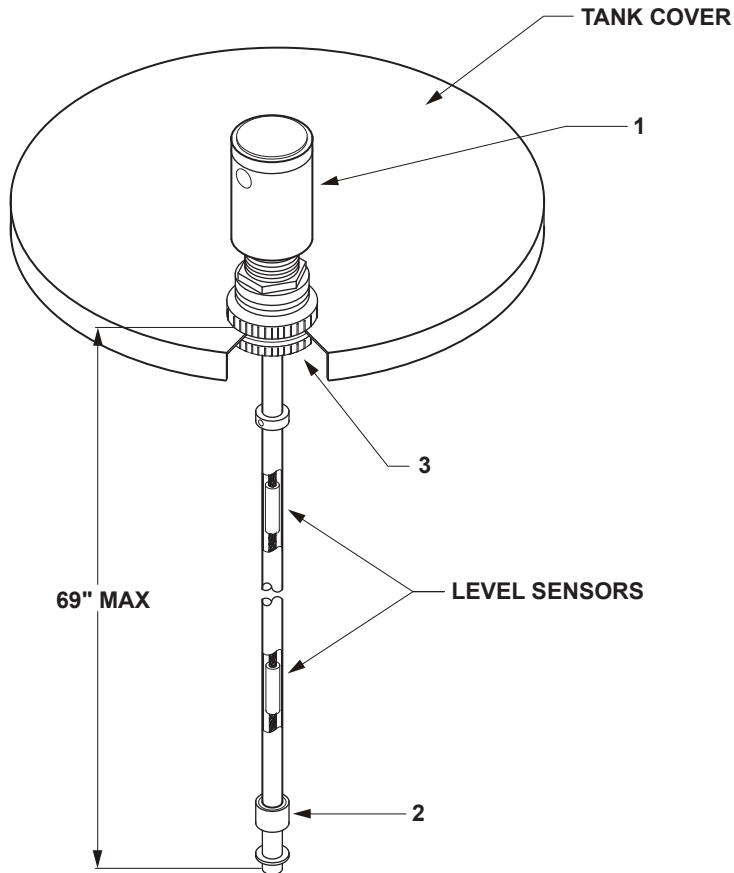

### SPECIFICATIONS

KEY	PART	DESCRIPTION
1		<b>CONTROLLER:</b> 115V / 1Ph / 60 Hz controller with PVC housing, 10 amp relay and 1/2" conduit connection
2	KK	<b>FLOAT:</b> Low voltage float, polypropylene and encapsulated reed switch
3		<b>TANK ADAPTER:</b> Constructed of grey Sch. 80 PVC with both threaded and slip connections and neoprene gasket

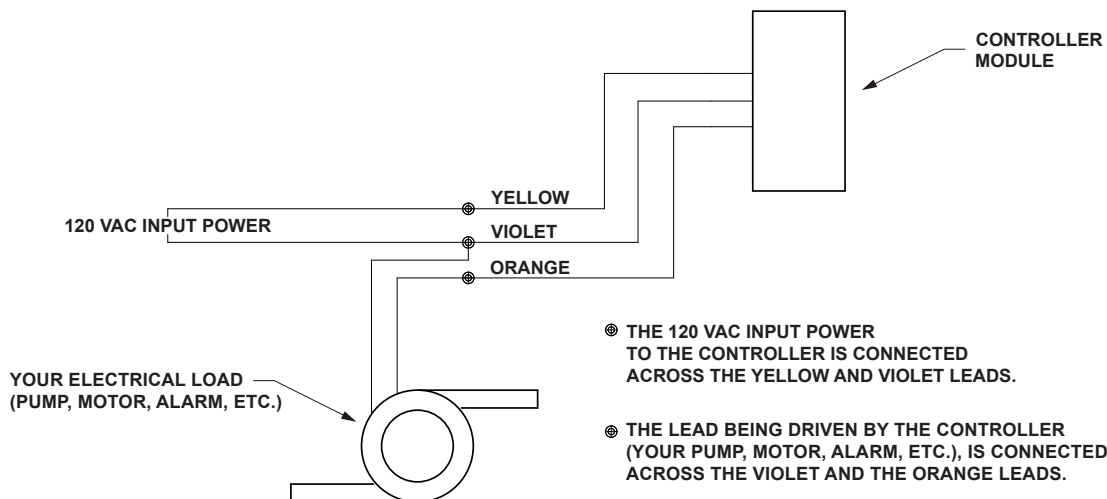

Note: All dimensions are +/- 1/8". All weights are approximate. All dimensions are subject to change without notice.

MANUFACTURING: Mixers, Bypass Feeders, Filter Feeders, Bromine Feeders, Sample Coolers, Sludge Traps, Separators, Separator Systems, Tank Stands, Tank Package Systems, Glycol Feed Systems, Coupon Racks, Control Stations, NEMA Enclosures, Custom Packaged Systems and Specialty Welding

P.O. Box 6207 | Garden Grove, CA 92846-6207 / 11800 Monarch St. | Garden Grove, CA 92841-2113 | Phone (714) 379-5519 | Fax (714) 379-5549  
Northern California Region | Phone (510) 487-5310 | Southwest Region | Phone (602) 470-1015 | Email: customerservice@jllwingert.com

[www.jllwingert.com](http://www.jllwingert.com)