

# J.L. WINGERT CO.

## Specification Sheet CONICAL TANK STAND MODEL CTS[ ]

SS100004.E 02/17

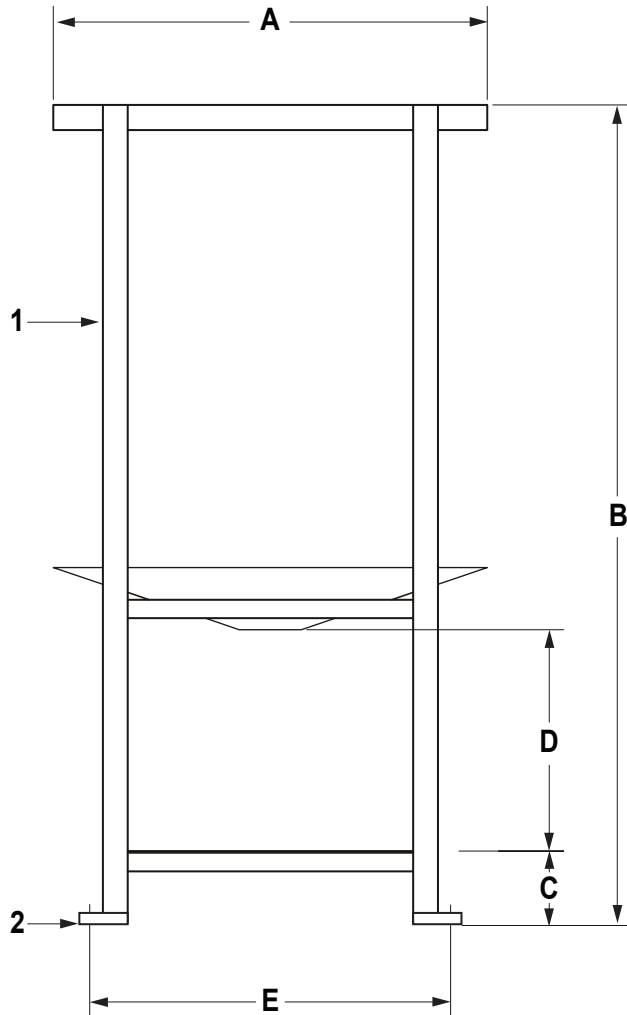

### SPECIFICATIONS

KEY	PART	DESCRIPTION
1	CTS [*]	<b>TANK STAND:</b> Constructed of carbon steel and painted with water based enamel
2		<b>FOOT PAD:</b> Constructed of 3/16" thick steel with bolt hole

\*NOTE: Place gallons inside [ ] for complete part number.

### DIMENSIONS

KEY	CTS10	CTS15	CTS30	CTS55	CTS70	CTS100	CTS200	CTS275
<b>A</b>	17 3/4"	18 1/4"	18 3/4"	22 1/4"	24 1/4"	32 3/4"	36 3/4"	43"
<b>B</b>	36"	41 5/8"	52 3/8"	63 3/16"	63 3/16"	56 3/16"	78 3/16"	72 3/16"
<b>C</b>	6 3/16"	6 3/16"	6 3/16"	6 3/16"	6 3/16"	6 3/16"	6 3/16"	6 3/16"
<b>D</b>	18"	18"	18"	18"	18"	18"	18"	18"
<b>E</b>	15 1/2"	15 7/8"	16 1/4"	18 3/4"	20 1/8"	26 3/16"	29"	34 3/16"
<b>WEIGHT</b>	36 lbs.	40 lbs.	47 lbs.	56 lbs.	59 lbs.	62 lbs.	86 lbs.	162 lbs.

\*Bottom Plate is not standard equipment - Add "-B" when ordering

**Note: All dimensions are +/- 1/8". All weights are approximate. All dimensions are subject to change without notice.**

**MANUFACTURING:** Mixers, Bypass Feeders, Filter Feeders, Bromine Feeders, Sample Coolers, Sludge Traps, Separators, Separator Systems, Tank Stands, Tank Package Systems, Glycol Feed Systems, Coupon Racks, Control Stations, NEMA Enclosures, Custom Packaged Systems and Specialty Welding

P.O. Box 6207 | Garden Grove, CA 92846-6207 | 11800 Monarch St. | Garden Grove, CA 92841-2113 | Phone (714) 379-5519 | Fax (714) 379-5549  
Northern California Region | Phone (510) 487-5310 | Southwest Region | Phone (602) 470-1015 | Email: customerservice@jllwingert.com

[www.jllwingert.com](http://www.jllwingert.com)