

# J.L. WINGERT CO.

## Specification Sheet **COMPACT GLYCOL FEED SYSTEM WALL MOUNT BRACKET MODEL CWB**

SS164002.B 12/15

**SPECIFICATIONS**

KEY	DESCRIPTION
<b>CWB</b>	Powder coated carbon steel wall mount bracket for Compact Glycol Feed System
<b>SHIPPING DIMENSIONS:</b>	
	18" x 16" x 6"
<b>SHIPPING WEIGHT:</b>	
	13 lbs

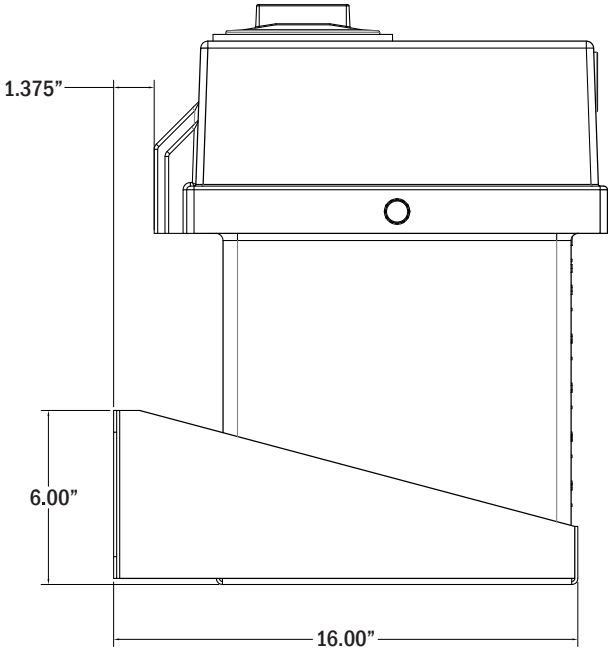
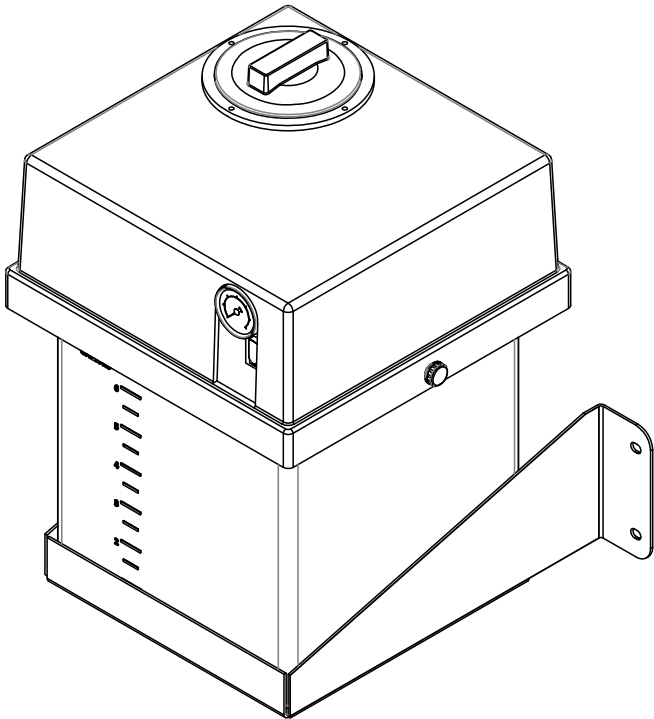
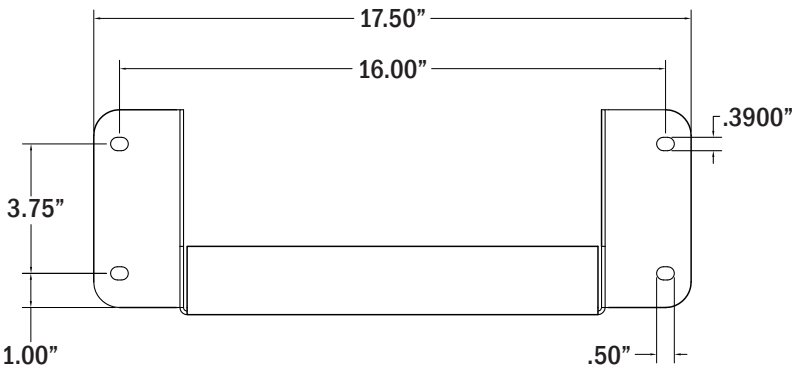

**Note: All dimensions are +/- 1/8". All weights are approximate. All dimensions are subject to change without notice.  
 The Compact Glycol Feed System is shown for reference only.**