

J.L. WINGERT CO.

Specification Sheet SEPARATOR MANUAL PURGE KITS MODELS PK-[]

SS052205.C 03/16

SPECIFICATIONS:

VALVE	Brass, 600 PSI WOG, full port ball valve
--------------	--

MODEL:	DESCRIPTION
--------	-------------

PK-0075	3/4" NPT manual purge kit
----------------	---------------------------

PK-0150	1 1/2" NPT manual purge kit
----------------	-----------------------------

PK-0200	2" NPT manual purge kit
----------------	-------------------------

DIMENSIONS:

KEY	PK-0075	PK-0150	PK-0200
A	13 3/16"	15 1/4"	13 7/8"
WEIGHT	Up to 8 lbs.		

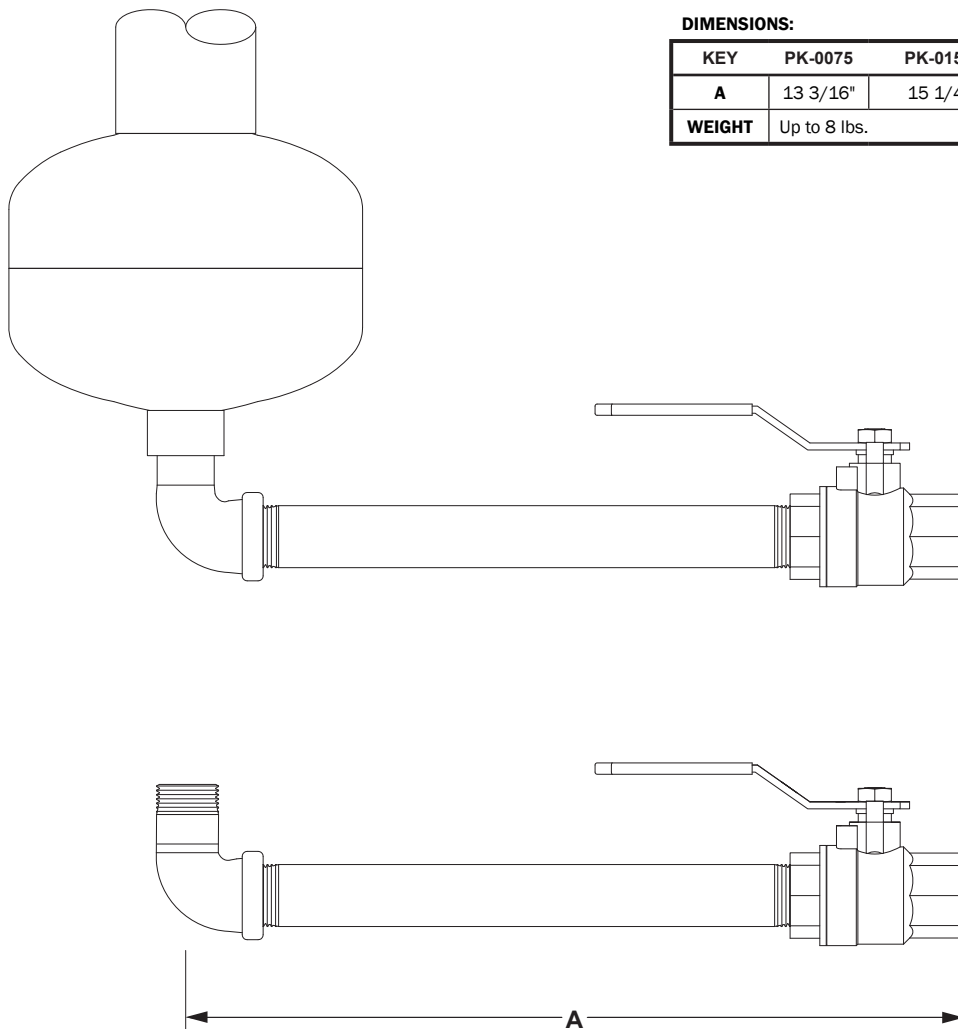

Note: All dimensions are +/- 1/8". All weights are approximate. All dimensions are subject to change without notice.

MANUFACTURING: Mixers, Bypass Feeders, Filter Feeders, Bromine Feeders, Sample Coolers, Sludge Traps, Separators, Separator Systems, Tank Stands, Tank Package Systems, Glycol Feed Systems, Coupon Racks, Control Stations, NEMA Enclosures, Custom Packaged Systems and Specialty Welding

P.O. Box 6207 | Garden Grove, CA 92846-6207 | 11800 Monarch St. | Garden Grove, CA 92841-2113 | Phone (714) 379-5519 | Fax (714) 379-5549
Northern California Region | Phone (510) 487-5310 | Southwest Region | Phone (602) 470-1015 | Email: customerservice@jllwingert.com

www.jllwingert.com