

J.L. WINGERT CO.

Specification Sheet 4" TO 20" FLANGED SEPARATORS MODELS XFD-[]

SS050050.A 03/16

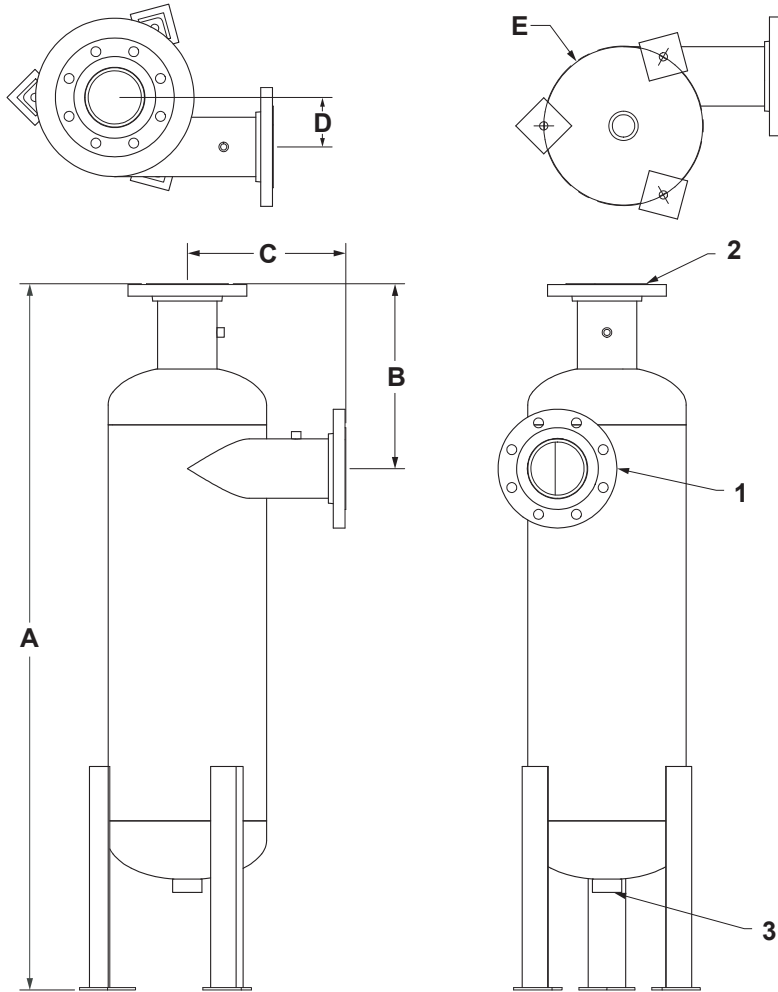

SPECIFICATIONS:

XFD-[]

Body is constructed of carbon steel, with ANSI 150# RF/SO flanges and painted with a water based enamel.

FLOW RANGE:

MODEL	4 PSI DROP	12 PSI DROP
XFD-0400	352 GPM	610 GPM
XFD-0500	554 GPM	959 GPM
XFD-0600	800 GPM	1,385 GPM
XFD-0800	1,385 GPM	2,398 GPM
XFD-1000	2,183 GPM	3,780 GPM
XFD-1200	2,915 GPM	5,049 GPM
XFD-1400	3,817 GPM	6,610 GPM
XFD-1600	5,056 GPM	8,757 GPM
XFD-1800	6,469 GPM	11,204 GPM
XFD-2000	8,056 GPM	13,953 GPM

MODEL SHOWN: XFD-0400

DIMENSIONS:

KEY	XFD-0400	XFD-0500	XFD-0600	XFD-0800	XFD-1000	XFD-1200	XFD-1400	XFD-1600	XFD-1800	XFD-2000
1	4" flanged	5" flanged	6" flanged	8" flanged	10" flanged	12" flanged	14" flanged	16" flanged	18" flanged	20" flanged
2	4" flanged	5" flanged	6" flanged	8" flanged	10" flanged	12" flanged	14" flanged	16" flanged	18" flanged	20" flanged
3	1 1/2" FNPT	1 1/2" FNPT	1 1/2" FNPT	1 1/2" FNPT	1 1/2" FNPT	2" FNPT	2" FNPT	2" FNPT	2" FNPT	2" FNPT
A	53 1/2"	53 1/2"	60 1/2"	70 1/2"	86 1/2"	100 1/2"	111 1/2"	125 1/2"	132 1/2"	135 1/2"
B	14"	14"	15 5/16"	17 5/16"	19 3/8"	22"	23"	24"	26 1/2"	29"
C	12"	12"	13"	15"	17"	18"	21"	21"	24"	27"
D	3 3/4"	3 1/4"	3 11/16"	4 11/16"	5 5/8"	5 5/8"	8"	7"	9"	11"
E	12 1/8"	12 1/8"	14 1/8"	18 3/16"	22"	24"	30"	30"	36 1/8"	42 1/8"
WEIGHT	159 lbs	172 lbs	232 lbs	374 lbs	565 lbs	804 lbs	1,428 lbs	1,570 lbs	2,142 lbs	2,464 lbs
PRESSURE	150 PSI (10.3 bar) max									
TEMPERATURE	200° F (93° C) max									

Note: All dimensions are +/- 1/8". All weights are approximate. All dimensions are subject to change without notice.

MANUFACTURING: Mixers, Bypass Feeders, Filter Feeders, Bromine Feeders, Sample Coolers, Sludge Traps, Separators, Separator Systems, Tank Stands, Tank Package Systems, Glycol Feed Systems, Coupon Racks, Control Stations, NEMA Enclosures, Custom Packaged Systems and Specialty Welding

P.O. Box 6207 | Garden Grove, CA 92846-6207 / 11800 Monarch St. | Garden Grove, CA 92841-2113 | Phone (714) 379-5519 | Fax (714) 379-5549
Northern California Region | Phone (510) 487-5310 | Southwest Region | Phone (602) 470-1015 | Email: customerservice@jllwingert.com

www.jllwingert.com