

J.L. WINGERT CO.

Specification Sheet 3" NPT SEPARATOR MODEL XTI-0300

SS050002.A 03/16

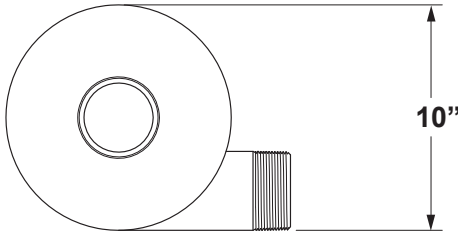

SPECIFICATIONS:

XTI-0300	Body is constructed of carbon steel and painted with water based enamel.
-----------------	--

FLOW RANGE:

MODEL	4 PSI DROP	12 PSI DROP
XTI-0300	205 GPM	355 GPM

DIMENSIONS:

KEY	DESCRIPTION
1	3" MNPT inlet
2	3" MNPT outlet
3	1 1/2" FNPT drain
WEIGHT	51 lbs
PRESSURE	150 PSI (10.3 bar) max
TEMPERATURE	200° F (93° C) max

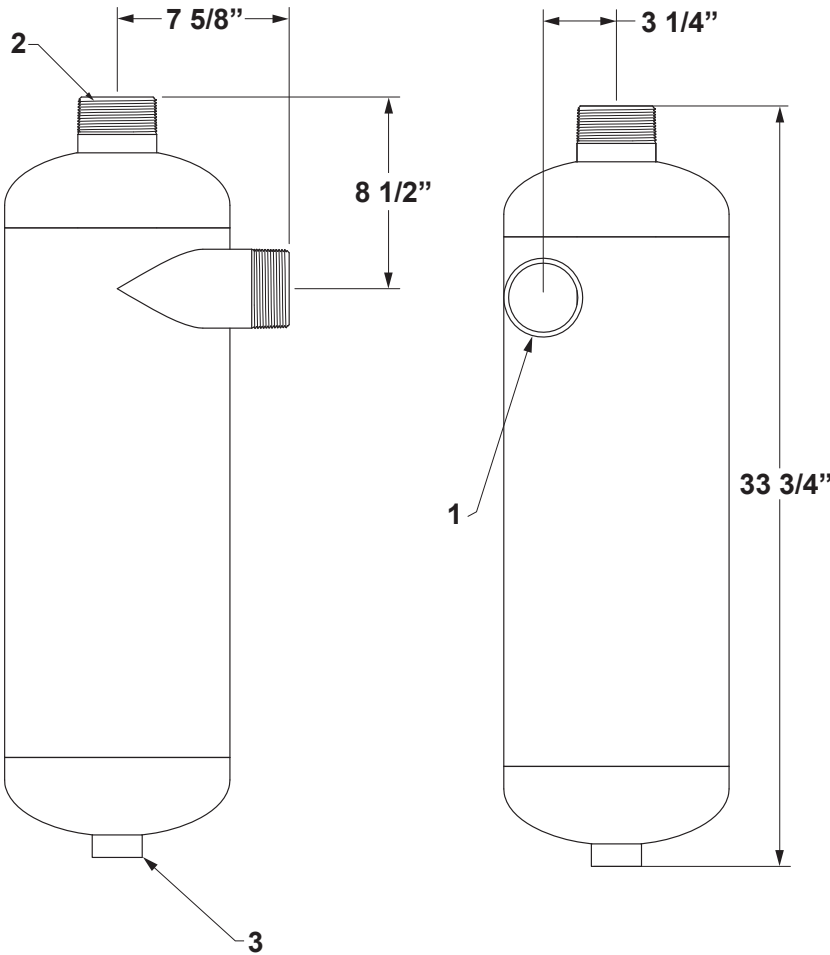

Note: All dimensions are +/- 1/8". All weights are approximate. All dimensions are subject to change without notice.