

PARTS LIST		
KEY	ITEM	DESCRIPTION
1	INET	2" FNPT FULL PORT BALL VALVE
2	STRAINER	2" CAST IRON W/ SS BASKET
3	SKID	CARBON STEEL SKID WITH ZINC PRIMER AND EPOXY TOP COAT
4	PUMP	GOULDS: 3AI1H9C0 100GPM @ 80TDH 3HP TEPE
5	SEPARATOR	XTI-0150
6	CONTROL PANEL	NEMA 4X ENCLOSURE MAIN POWER DISCONNECT MAIN POWER LED INDICATOR PUMP H-O-A SWITCH PUMP RUNNING LED INDICATOR PURGE H-O-A SWITCH SYSTEM PURGE LED INDICATOR 460VAC TO 120VAC TRANSFORMER PUMP CONTACTOR AND OVERLOAD PROGRAMMABLE PURGE CONTROL TERMINALS FOR EXTERNAL PURGE COMMAND
7	MOTORIZED PURGE	3/4" FULL PORT 120VAC ACTUATED BALL VALVE
8	DISCHARGE	1-1/2" FNPT FULL PORT BALL VALVE

DRAWN	RB	4/8/2020	J.L. WINGERT CO.
CHECKED			
QA			
MFG			
APPROVED			TITLE
			JLW 100GPM @ 80TDH SEPARATOR SYSTEM - SUBMITTAL
			SIZE
			C
			DWG NO
			CT-0100-80-MPK_BS
			REV
			SCALE
			1 / 9
			SHEET 1 OF 1

Customer	Date	08.04.2020
Contact	Project	
Phone number	Project no.	
Email		



3AI1H9C0

Operating data

Pump type	Fluid	Water
No. of pumps / Reserve	Operating temperature t A	°F 39.2
Nominal flow US g.p.m.	pH-value at t A	7
Nominal head ft	Density at t A	lb/ft ³ 62.4
Static head ft	Kin. viscosity at t A	ft ² /s 1.689E-5
Inlet pressure psi	Vapor pressure at t A	psi 14.5
Environmental temperature °F	Solids	0
Available system NPSH ft	Altitude	ft 0

Pump data

Make	Goulds Water Technology	Nominal	US g.p.m.	105.1	(105.1)
Speed	rpm 3600	Flow	Max-	US g.p.m.	157.5
No. of stages	1		Min-	US g.p.m.	
Max. casing pressure	psi		Nominal	ft	88.3
Max. working pressure	psi 49	Head	at Qmax	ft	30.2
Head H(Q=0)	ft 110		at Qmin	ft	113
Weight	lb 151	Shaft power		hp	3.3 (3.3)
	Max. inch 5 15/16	Max. shaft power		hp	3.5
Impeller R	designed inch 5 1/8	Efficiency		%	70.84
	Min. inch 4 3/4	NPSH 3%		ft	7.6

Shaft Seal

Type 21	Xylem
(10K13) Car/Cer/Buna [Max Temp. 212°F/100°C] (Std.)	
Rotary	Carbon
Stationary	Ceramic
Elastomers	Buna-N
Metal Parts	316 SS
Application	General Use, Clean Water to 212°F/100°C, Non-Fluctuating Temp

Motor data

Specific design	3ph TEPE	Speed	3500 rpm	Insulation class	F
Electric voltage	460 V	Frame size	182JM	Colour	RAL 5010
Type	230/460V 182JM (C09A32F5BD2S)	Degree of protection	IP 55		
Rated power	3 hp	Electric current	3.6 A		

Remarks:

Customer	Date	08.04.2020
Contact	Project	
Phone number	Project no.	
Email		

3AI1H9C0

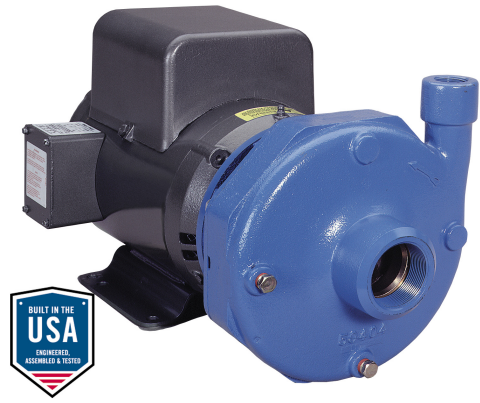

Pump Materials

100 - Casing	Gray cast iron ASTM A48 CL20B
101 - Impeller	Gray cast iron ASTM A48 CL20B
103 - Casing wear ring	Gray cast iron ASTM A48 CL20B
108 - Adapter	Gray cast iron ASTM A48 CL20B
184 - Seal housing (One piece with adapter)	Gray cast iron ASTM A48 CL20B
198 - Impeller bolt	AISI Type 300 series stainless steel
199 - Impeller washer	AISI Type 300 series stainless steel
178 - Impeller key	Carbon Steel
370 - Hex head cap screw (adapter to case)	Steel SAE 1200 Grade 5
371 - Hex head cap screw (adapter to motor)	Steel SAE 1200 Grade 5
383 - Mechanical seal	See seal chart
408 - Pipe plug 1/4" or 3/8"	Steel
513 - O-ring	BUNA-N

3656 S-GROUP MATERIALS OF CONSTRUCTION MATERIALES DE CONSTRUCCIÓN - GRUPO S, MODELO 3756

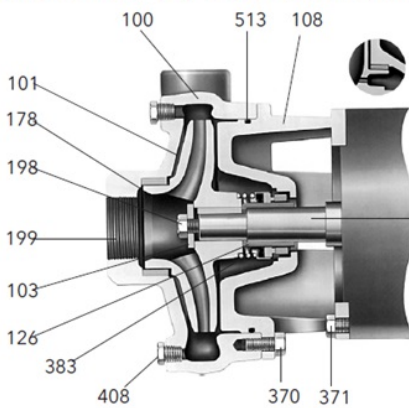

Back wearing ring on S-Group
(2½ x 3 - 7) only
*Anillo de desgaste posterior en el
Grupo S (2½ x 3 - 7) únicamente.*

AISI 1045 steel motor shaft
extension (typical)
*Extensión del eje del motor
de acero AISI 1045 (típico)*

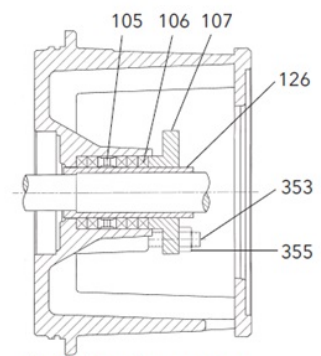

Packed Box Arrangement
Caja prensaestopas

Remarks:

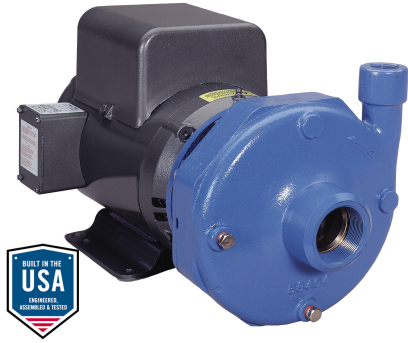

Customer	Date	08.04.2020
Contact	Project	
Phone number	Project no.	
Email		

3A1H9C0

Hydraulic Data

Operating Data Specification		Hydraulic data (duty point)		Impeller design	
Flow	100 US g.p.m.	Flow	105 US g.p.m.	Impeller R	5 1/8"
Head	80 ft	Head	88.3 ft	Frequency	60 Hz
Static head	0 ft	Head	88.3 ft	Speed	3600 rpm

Power datas referred to:
 Water [100%] ; 39.2°F; 62.4lb/ft³; 1.69E-5ft²/s
 Performance according to ISO 9906 - Annex A

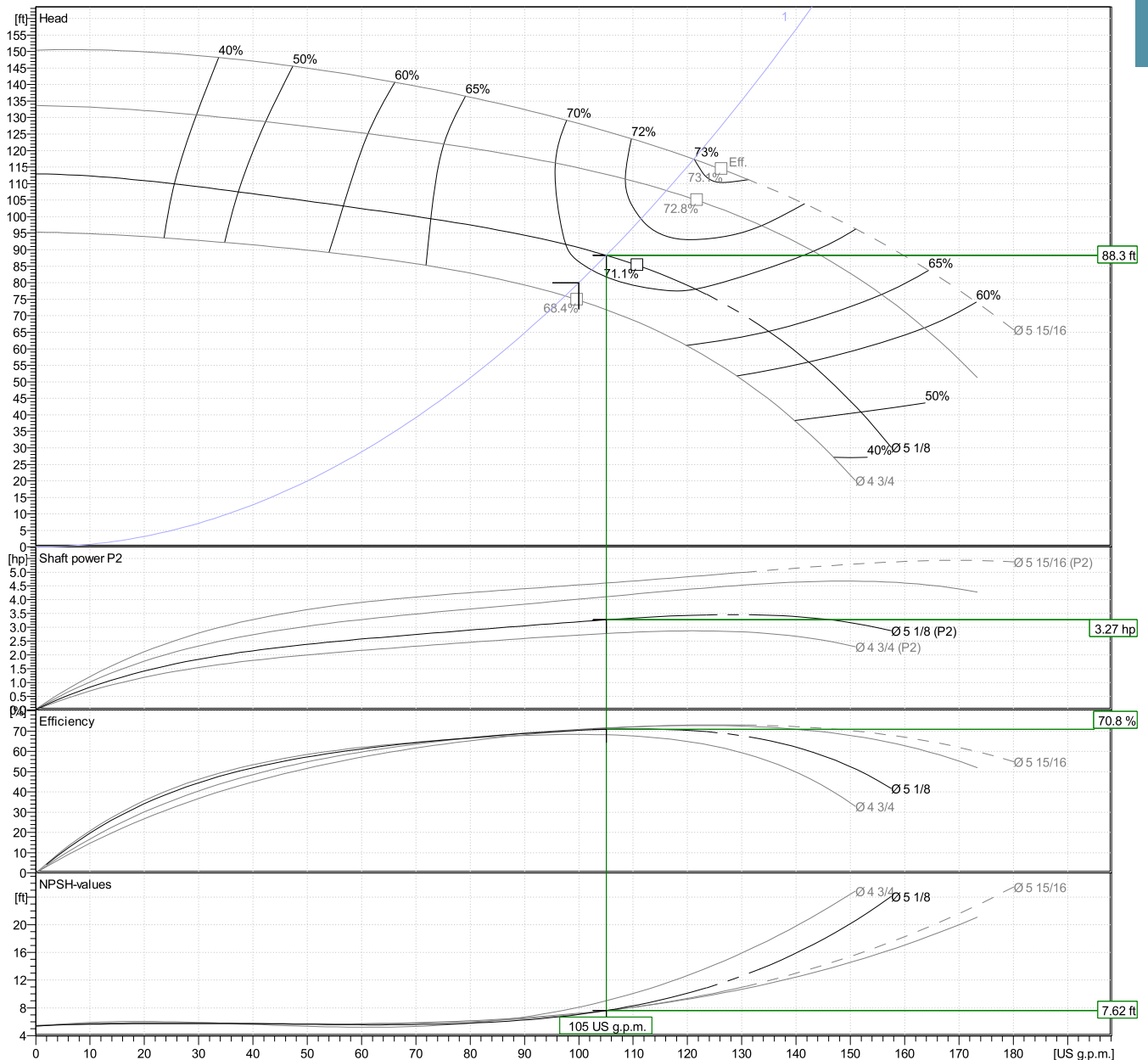

Customer	Date	08.04.2020
Contact	Project	
Phone number	Project no.	
Email		

3A11H9C0

Drawing

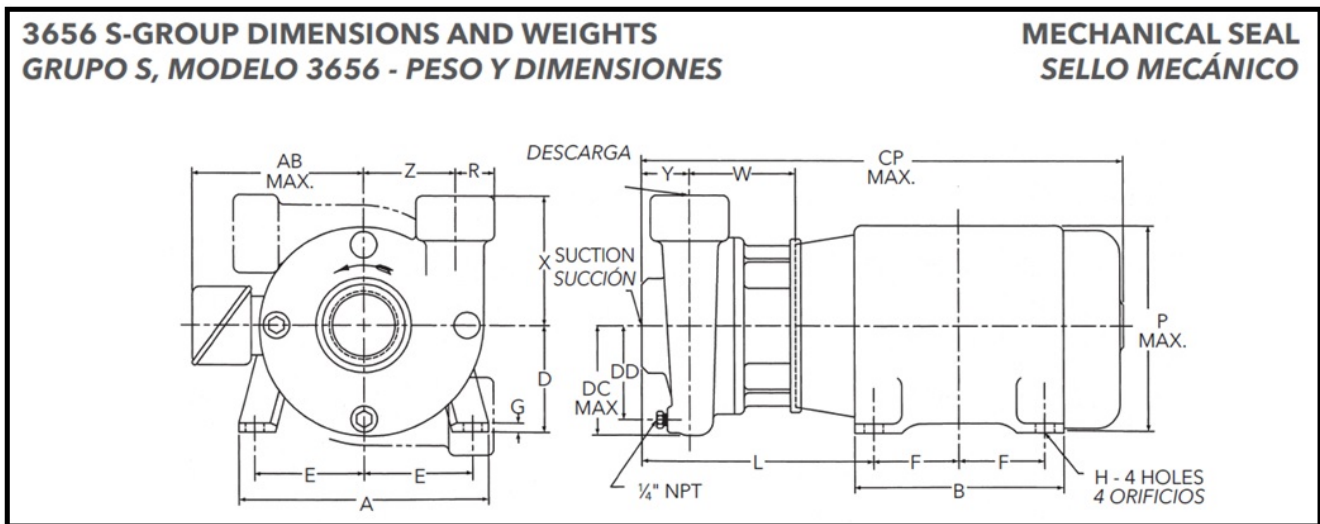

Dimensions inch

A	8 ¹¹ / ₁₆	F	2 ¹ / ₄	Y	2 ⁵ / ₈	Weight 150.84 lb
AB Max.	7 ¹ / ₂	G	3 ⁷ / ₈	Z	3 ¹ / ₂	
B	6 ¹ / ₂	H	10 ³ / ₈			
CP Max.	24 ¹ / ₂	L	9 ⁹ / ₁₆			
D	4 ¹ / ₂	P Max.	1 ¹ / ₄			
DC Max.	4 ¹ / ₄	R	2			
DD	3 ¹ / ₂	Suction	4 ¹ / ₄			
Discharge	1 ¹ / ₂	W	4 ¹ / ₂			
E	3 ³ / ₄	X				