

J.L. WINGERT CO.

Specification Sheet 5 FEET PER SECOND FLOW CONTROL VALVE OPTION 18

SS163518.D 05/16

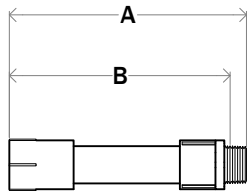

OPTION 18 FOR
PCR CORROSION
COUPON RACK



OPTION 18 FOR
CCR CORROSION
COUPON RACK



OPTION 18 FOR
CSCR CORROSION
COUPON RACK



OPTION 18 FOR
SSCR CORROSION
COUPON RACK

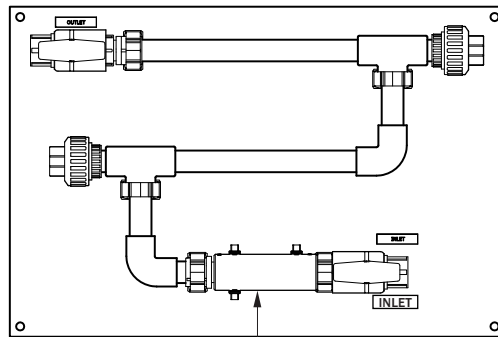

OPTION 18

EXAMPLE OF OPTION 18 ON CCR-2-007/18

KEY	DESCRIPTION	
1	INLET	3/4" MNPT
2	OUTLET	3/4" FNPT

DIMENSION	MODEL NUMBER			
	PCR_-007	CCR_-007	CSCR_-007	SSCR_-007
A	6 5/8"	5 7/8"	2 1/2"	4 7/8"
B (INSTALLED LENGTH)	6 1/8"	5 3/8"	1 3/4"	4 3/8"
WETTED MATERIALS	Body: PVC Orifice: BUNA-N	Body: CPVC Cartridge: 304SS Seals: VITON®	Body: Carbon Steel Orifice: BUNA-N	Body: 316SS Cartridge: 304SS Seals: VITON®

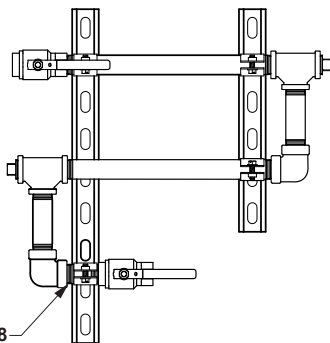

OPTION 18

EXAMPLE OF OPTION 18 ON CSCR-2-007/18

TEMPERATURE (°F / °C)	NON-SHOCK PRESSURE RATING							
	PVC		CPVC		Carbon Steel (CS)		316 Stainless Steel (SS)	
	PSI	BAR	PSI	BAR	PSI	BAR	PSI	BAR
73° / 23°	150.0	10.4	235.0	16.2	150.0	10.4	300.0	20.6
90° / 32°	112.5	7.7	213.8	14.7	112.5	7.7	300.0	20.6
110° / 43°	75.0	5.2	180.9	12.4	75.0	5.2	300.0	20.6
130° / 54°	45.0	3.1	145.7	10.0	45.0	3.1	300.0	20.6
150° / 66°	N/A	N/A	110.4	7.6	N/A	N/A	300.0	20.6
200° / 93°	N/A	N/A	47.0	3.2	N/A	N/A	265.0	18.2
250° / 121°	N/A	N/A	N/A	N/A	N/A	N/A	185.0	12.7

**Note: All dimensions are +/- 1/8". All dimensions are subject to change without notice.
See Operation & Maintenance Manual for part numbering.**

MANUFACTURING: Mixers, Bypass Feeders, Filter Feeders, Bromine Feeders, Sample Coolers, Sludge Traps, Separators, Separator Systems, Tank Stands, Tank Package Systems, Glycol Feed Systems, Coupon Racks, Control Stations, NEMA Enclosures, Custom Packaged Systems and Specialty Welding

P.O. Box 6207 | Garden Grove, CA 92846-6207 / 11800 Monarch St. | Garden Grove, CA 92841-2113 | Phone (714) 379-5519 | Fax (714) 379-5549
Northern California Region | Phone (510) 487-5310 | Southwest Region | Phone (602) 470-1015 | Email: customerservice@jllwingert.com

www.jllwingert.com