



SEPARATOR PURGE SYSTEM

OPERATION & MAINTENANCE MANUAL

PLEASE RECORD THE FOLLOWING DATA

(Information is located on the product label or packing slip)

Model Number: _____

Date Code: _____

Installation Date: _____

Installation Location / Application: _____

The above information will help when ordering replacement parts for your Wingert Purge System.

MANUFACTURING: *Mixers, Bypass Feeders, Filter Feeders, Bromine Feeders, Sample Coolers, Sludge Traps, Separators, Separator Systems, Tank Stands, Tank Package Systems, Glycol Feed Systems, Coupon Racks, Control Stations, NEMA Enclosures, Custom Packaged Systems and Specialty Welding*

P.O. Box 6207 • Garden Grove, CA 92846-6207 / 11800 Monarch St. • Garden Grove, CA 92841-2113 • Phone (714) 379-5519 • Fax (714) 379-5549
Northern California Region • (510) 487-5310 ■ Southwest Region • (602) 470-1015 ■ Email: customerservice@jllwingert.com
www.jllwingert.com

O&M Manual
INT0521.F 12/03

CONTENTS:	PAGE
1.0 INTRODUCTION	1
2.0 WARRANTY	1
3.0 UNPACKING	1
4.0 LOCATION AND ENVIRONMENT	1
5.0 INSTALLATION	2
5.1 MANUAL PURGE SYSTEMS	2
5.2 AUTOMATIC PURGE SYSTEMS	2
5.3 CONTINUAL PURGE SYSTEMS	3
6.0 WIRING	3
7.0 DETERMINING PURGE CYCLES	3
8.0 MAINTENANCE	3

1.0 INTRODUCTION

A Wingert Separator Purge System will complete any separator installation. In the following paragraphs, we will advise you on how a purge system is used and why it is needed.

2.0 WARRANTY

Wingert Separator Purge Systems are guaranteed for one year from the date of shipment against manufacturing defects in material and workmanship which develop in the service for which they are designed. We will repair or replace defective material when returned to our factory with transportation prepaid: providing that the material is found to be defective upon inspection. We assume no liability for labor and/or other expenses in making repairs or adjustments. All replacements will be F.O.B. factory.

3.0 UNPACKING

*Wingert Separator Purge Systems are assembled and ready for installation. All purge systems are shipped in a carton. Unpack and inspect for physical damage. If the purge system is damaged and not noted with the freight carrier, contact the factory immediately for assistance. **NOTE:** You only have 3-5 days after receipt of goods to file a freight claim. Verify that what you ordered is what you have received.*

4.0 LOCATION AND ENVIRONMENT

Every installation is different. The separator and purge system may be located indoors or outdoors with shelter from regional weather conditions. All electrical connections should be done by a qualified electrician to meet local building codes. Consult factory for harsh environments or direct exposure to the elements.

5.0 INSTALLATIONS

There are three standard purging options available. See "DETERMINE PURGE CYCLES" (page 3) for help with purge cycles.

5.1 MANUAL PURGE SYSTEMS

A manual purge system, as diagramed to the right, is all that is needed to perform the only maintenance required by a separator. Infrequent opening of a full port ball valve will clean the solids collection chamber.

System flow is cycled through the inlet and outlet of the separator. Solids are slung to the perimeter of the separator and collected in the chamber at the bottom.

System pressure will help in removing the solids when the purge valve is opened.

For best results, purge while system is in full operation.

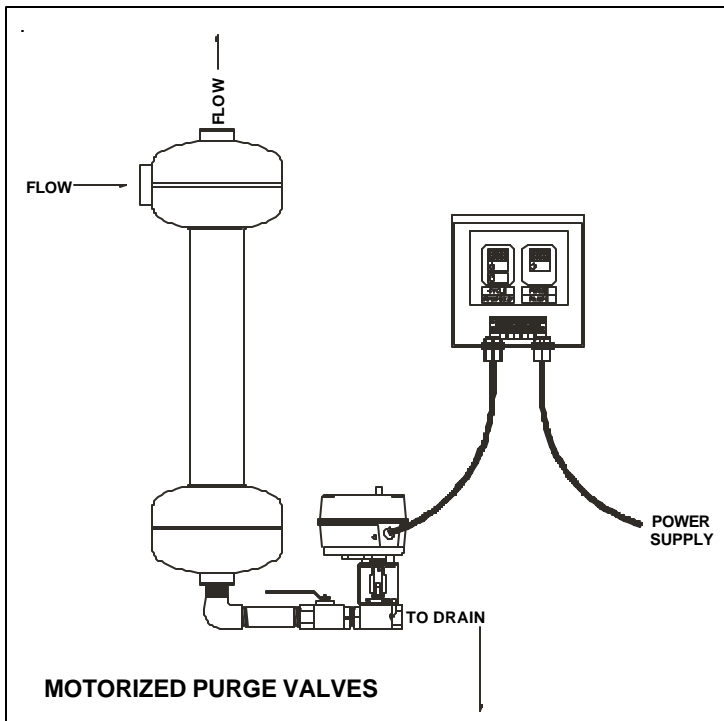
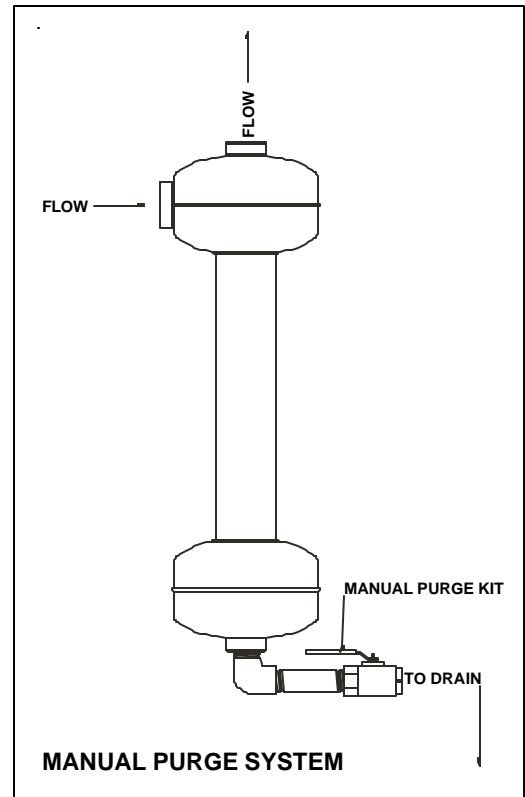

5.2 AUTOMATIC PURGE SYSTEMS

Automatic Purge Systems are convenient for remote locations or where frequent purging is required.

Fitted with electronically-actuated motorized ball valves, these systems are controlled with reliable timing devices having programmable options for both frequency and duration of solids purging.

Additionally, a manual isolation or purge kit should be installed in case of power failure or service work to motorized valve.

5.0 INSTALLATIONS (CONTINUED)

5.3 CONTINUAL PURGE SYSTEM

Unlike other purge systems, the continual purge system is always at work. This type of system removes solids as they collect in the solids collection chamber.

This type of purge system is required when high solids content is present or when system fluid can not be discarded.

This system uses an isolated chamber, filter bag and basket to collect all solids. Flow control valves are used to keep flow to a minimum. As an option, a service indicator package (which includes a flow switch, isolation valves, dry contact) can be used to tell when the vessel needs service.

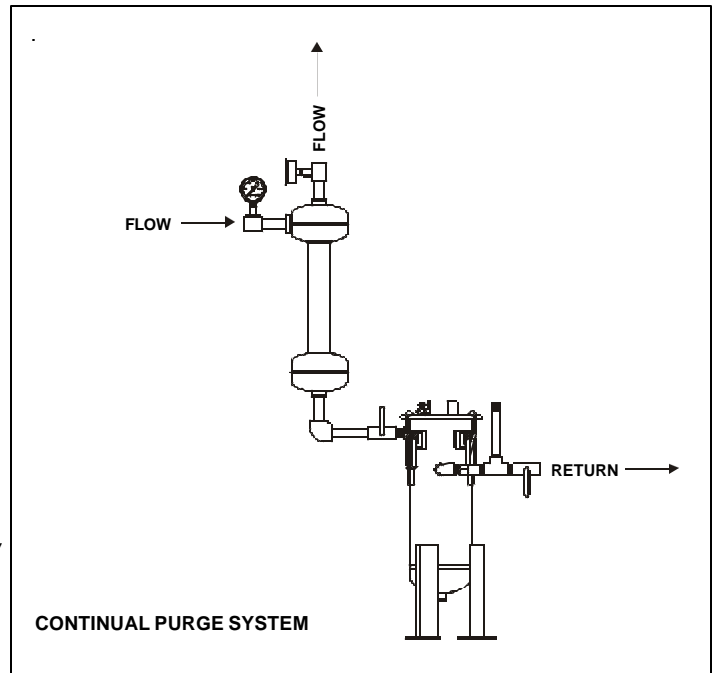

Once service is need, vessel can be isolated (causing no down time), pressure released, solids discarded and the system placed back in service.

6.0 WIRING

Both cycle timers (deluxe and economy) use the same wiring diagram. Be sure power is disconnected before servicing or connecting power. All wiring should be done by a qualified electrician to meet local electrical codes.

7.0 DETERMINE PURGE CYCLES

If purging is not done regularly, accumulated solids could overflow the collection chamber and adversely affect the separators performance.

For best results when using a pre-selected purge system (manual, automatic or continual,) purge while the system is in full operation. To determine the necessary frequency, purge often at first; then calculate the rate with regard to the actual volume of separated solids.

8.0 MAINTENANCE

Purge systems need very little maintenance. Occasionally, timers and electrical connections should be inspected for moisture and corrosion; ball valve and handle should be inspected for wear.