

J.L. WINGERT CO.

P.O. Box 6207 • Garden Grove, CA 92846-6207 / 11800 Monarch Street • Garden Grove, CA 92841-2113
 Phone (714) 379-5519 • Fax (714) 379-5549 ■ Email: customerservice@jllwingert.com
 Northern California Region • Phone (510) 487-5310 ■ Southwest Region • Phone (602) 470-1015
 www.jllwingert.com

MANUFACTURING: Mixers, Bypass Feeders, Filter Feeders, Bromine Feeders, Sample Coolers, Sludge Traps, Separators, Separator Systems, Tank Stands,
 Tank Package Systems, Glycol Feed Systems, Coupon Racks, Control Stations, NEMA Enclosures, Custom Packaged Systems and Specialty Welding

Specification Sheet #291001 Rev. "B" (01/05)

STRIPCHART RECORDERS

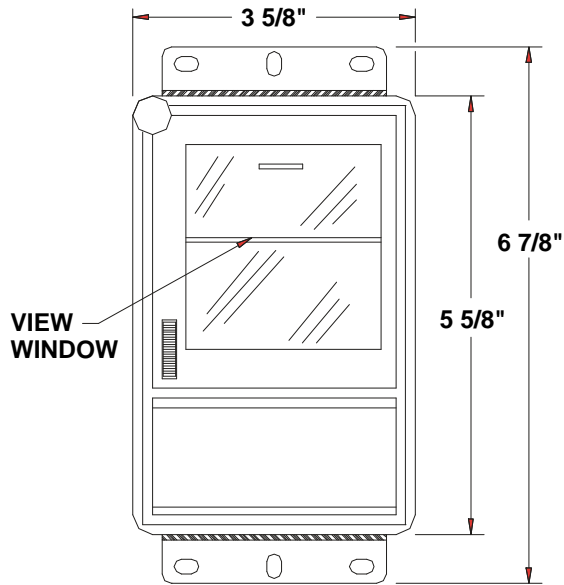

FRONT VIEW

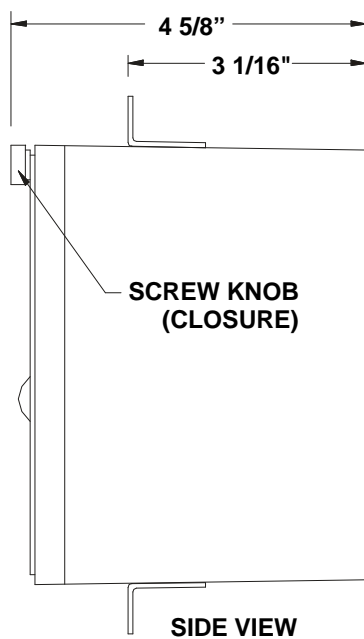

SIDE VIEW

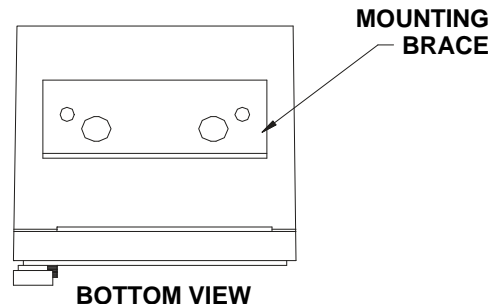

BOTTOM VIEW

PART	DESCRIPTION
CT1201-20	STRIPCHART RECORDER: 4-20 mA input
2196	ESCUTCHEON PLATE: (panel mount)
MG651	CHART ROLLS: Six in a box, each 63 ft. long available in scale ranges 0-100%, 0-14pH, 0-10", 0-20", 0-50"

* Standard units such as GPM and LPM will be added to these scales upon request

SPECIFICATIONS

ACCURACY	+/-2% for span for DC and temperature inputs, +/-3% for span for AC inputs
RESPONSE TIME	1 second max
OVERRANGE (SHORT TERM)	200%
OVERRANGE (CONTINUOUS)	150%
OPERATING TEMPERATURE	0 TO 120° F
ENVIRONMENT	Indoor - Outdoor w/enclosure
RECORDING WIDTH	2"
DIMENSIONS	3 5/8" W x 5 5/8" H x 4 5/8" D
POWER	100-130 V/60 Hz or 220 V/50 Hz
PACKAGE	Molded ABS
WEIGHT	3.5 lbs.

Note: All weights are approximate. All dimensions are subject to change without notice.