

# J.L. WINGERT CO.

P.O. Box 6207 • Garden Grove, CA 92846-6207 / 11800 Monarch Street • Garden Grove, CA 92841-2113  
 Phone (714) 379-5519 • Fax (714) 379-5549 ■ Email: customerservice@jllwingert.com  
 Northern California Region • Phone (510) 487-5310 ■ Southwest Region • Phone (602) 470-1015  
 www.jllwingert.com

MANUFACTURING: Mixers, Bypass Feeders, Filter Feeders, Bromine Feeders, Sample Coolers, Sludge Traps, Separators, Separator Systems, Tank Stands,  
 Tank Package Systems, Glycol Feed Systems, Coupon Racks, Control Stations, NEMA Enclosures, Custom Packaged Systems and Specialty Welding

Specification Sheet #165004 Rev. "G" (03/08)

## "GL50-H1" HIGH TEMPERATURE GLYCOL FEED SYSTEM

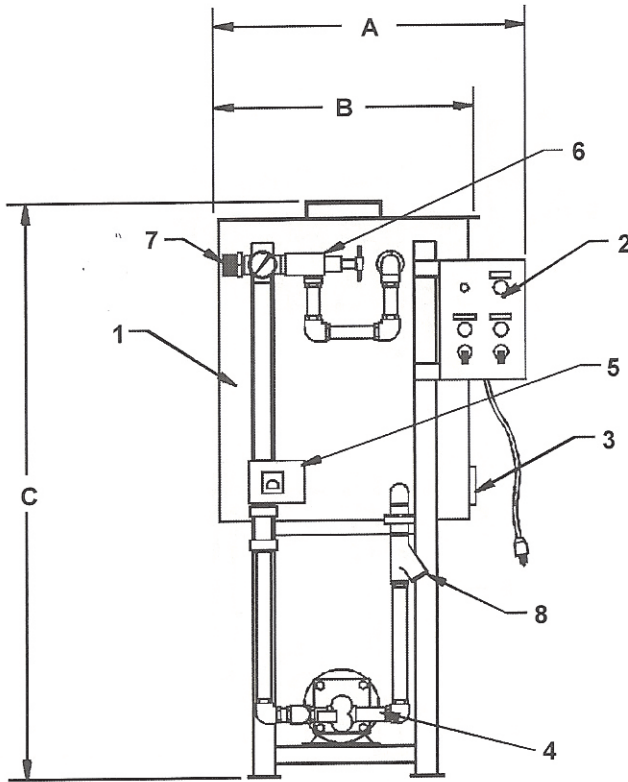

FRONT VIEW

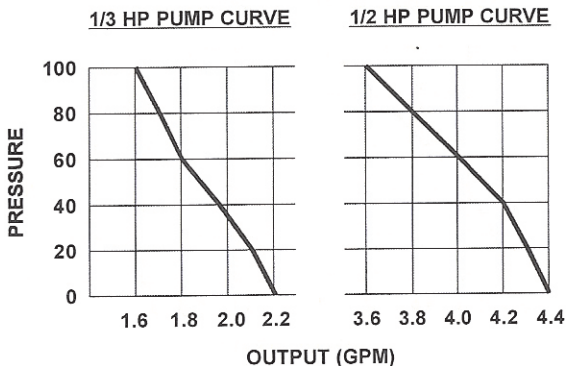

### MATERIALS AND SPECIFICATIONS:

KEY	SPECIFICATIONS
1	TANK: 50 gallon carbon steel tank with 1/3 hinged carbon steel cover • Tank is fully supported and restrained by a carbon steel bottom mount stand that is painted with water based enamel
2	CONTROL PANEL: The NEMA 4X control panel comes standard with 8 ft., 115V power cord • The control panel includes 2-position main power switch and light, 3-position (handoff/auto) switch and light for gear pump, red low level light and 15 AMP fuse
3	LOW LEVEL SWITCH: Polypropylene side entry low level switch with 10 AMP relay
4	GEAR PUMP: 1/3HP gear pump provides steady and even flow against pressure (see curve below) • Pump suction plumbing includes brass ball valve, cast iron Y-strainer and carbon steel piping • Pump discharge includes steel spring check valve, carbon steel piping and 1/4" NPT back tap pressure gauge
5	PRESSURE SWITCH: 1/4" NPT pressure switch
6	PRESSURE RELIEF VALVE: 5-300 PSI pressure relief valve and gauge
7	OUTLET: 3/4" MNPT
8	SUCTION VALVE: with Y-strainer
MAX. PRESSURE	100 PSI (6.9 BAR)
MAX. TEMPERATURE	125° F (52° C)

### PRESSURE SETTING TABLE

CODE	CUT-IN	CUT-OUT	PSI DIFFERENTIAL
Code 1*	10-40	20-60	10-40
Code 2	40-80	65-100	20-40
Code 3	3-10	9-30	6-20

\* NOTE: Code 1 is standard. Listed optional settings are available at no extra charge. Other settings or ranges are available upon request, consult factory for pricing.

### DIMENSIONS, WEIGHT & CUBE:

KEY	GL50-H
A	31"
B	24 1/4"
C	59 3/4"
WEIGHT	195 lbs. (88.5 kgs.)
CUBE	31" X 31" X 60"

### OPTIONAL FEATURES

- Audible alarm and silence switch
- Additional PSI control ranges
- Additional pump ranges and HP's
- Tank capacities

Note: All dimensions are +/- 1/8". All weights are approximate. All dimensions are subject to change without notice.