

J.L. WINGERT CO.

P.O. Box 6207 • Garden Grove, CA 92846-6207 / 11800 Monarch Street • Garden Grove, CA 92841-2113
 Phone (714) 379-5519 • Fax (714) 379-5549 ■ Email: customerservice@jllwingert.com
 Northern California Region • Phone (510) 487-5310 ■ Southwest Region • Phone (602) 470-1015
 www.jllwingert.com

J.L. WINGERT MANUFACTURED PRODUCTS: Mixers, Bypass Feeders, Filter Feeders, Bromine Feeders, Sample Coolers, Sludge Traps, Separators, Separator Systems, Tank Stands, Tank Package Systems, Glycol Feed Systems, Coupon Racks, Control Stations, NEMA Enclosures, Custom Packaged Systems and Specialty Welding

Specification Sheet #165002 Rev. "O" (11/11)

"GL50-E1" ECONOMY GLYCOL FEED SYSTEM

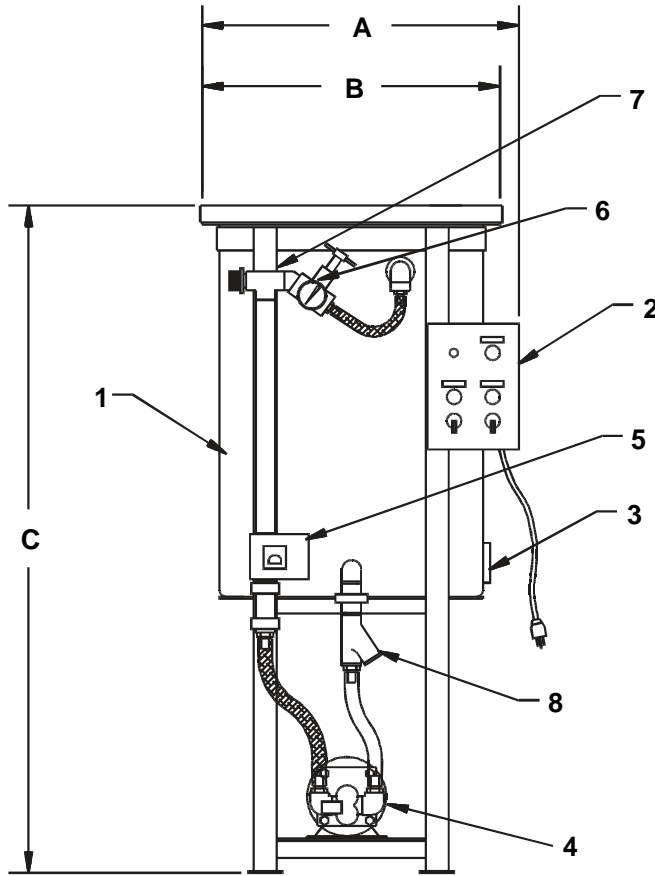

FRONT VIEW

MATERIALS AND SPECIFICATIONS:

KEY	SPECIFICATIONS
1	TANK: 50 gallon polyethylene tank with 1/3 hinged PE cover • Tank is fully supported and restrained by a carbon steel bottom mount stand that is painted with water based enamel
2	CONTROL PANEL: The NEMA 4X control panel comes standard with 8 ft., 115V power cord • The control panel includes 2-position main power switch and light, 3-position (hand/off/auto) switch and light for gear pump, red low level light and 15 AMP fuse
3	LOW LEVEL SWITCH: Polypropylene side entry low level switch with 10 AMP relay
4	GEAR PUMP: 1/3HP gear pump provides steady and even flow against pressure (see curve below) • Pump suction plumbing includes PVC ball valve, flexible tubing and cast iron Y-strainer • Pump discharge tubing includes brass construction spring check valve, PVC piping and 1/4" NPT back tap pressure gauge
5	PRESSURE SWITCH: 1/4" NPT pressure switch
6	PRESSURE RELIEF VALVES: 50-250 PSI Brass Pressure Relief Valve
7	OUTLET: 3/4" MNPT
8	SUCTION VALVE: with Y-strainer
MAX. PRESSURE 100 PSI (6.9 BAR)	
MAX. TEMPERATURE 85° F (29° C)	

PRESSURE SETTING TABLE

CODE	CUT-IN	CUT-OUT	PSI DIFFERENTIAL
Code 1*	10-40	20-60	10-40
Code 2	40-80	65-100	20-40
Code 3	3-10	9-30	6-20

* NOTE: Code 1 is standard. Listed optional settings are available at no extra charge. Other settings or ranges are available upon request, consult factory for pricing.

DIMENSIONS, WEIGHT & CUBE:

KEY	GL50-E1
A	31"
B	24 1/4"
C	59 3/4"
WEIGHT	150 lbs. (68 kgs.)
CUBE	31" X 31" X 60"

OPTIONAL FEATURES

Audible alarm and silence switch	
Additional PSI control ranges	
Additional pump ranges and HP's	
Dry contact	Tank capacities

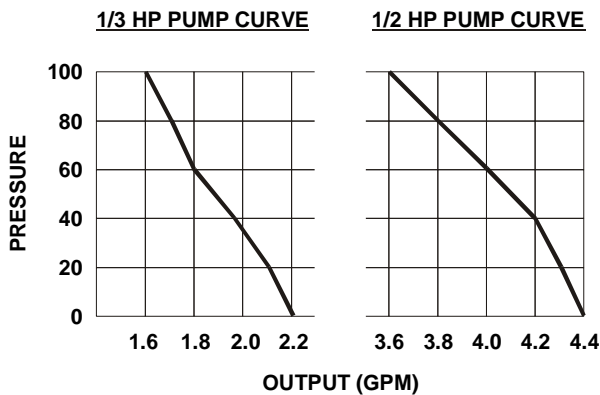

Note: All dimensions are +/- 1/8". All weights are approximate. All dimensions are subject to change without notice.