

J.L. WINGERT CO.

P.O. Box 6207 • Garden Grove, CA 92846-6207 / 11800 Monarch Street • Garden Grove, CA 92841-2113
 Phone (714) 379-5519 • Fax (714) 379-5549 ■ Email: customerservice@jllwingert.com
 Northern California Region • Phone (510) 487-5310 ■ Southwest Region • Phone (602) 470-1015
 www.jllwingert.com

MANUFACTURING: Mixers, Bypass Feeders, Filter Feeders, Bromine Feeders, Sample Coolers, Sludge Traps, Separators, Separator Systems, Tank Stands,
 Tank Package Systems, Glycol Feed Systems, Coupon Racks, Control Stations, NEMA Enclosures, Custom Packaged Systems and Specialty Welding

Specification Sheet #102209 Rev. "C" (3/00)

OPTION "-KK" HIGH-LOW LEVEL CONTROLLER

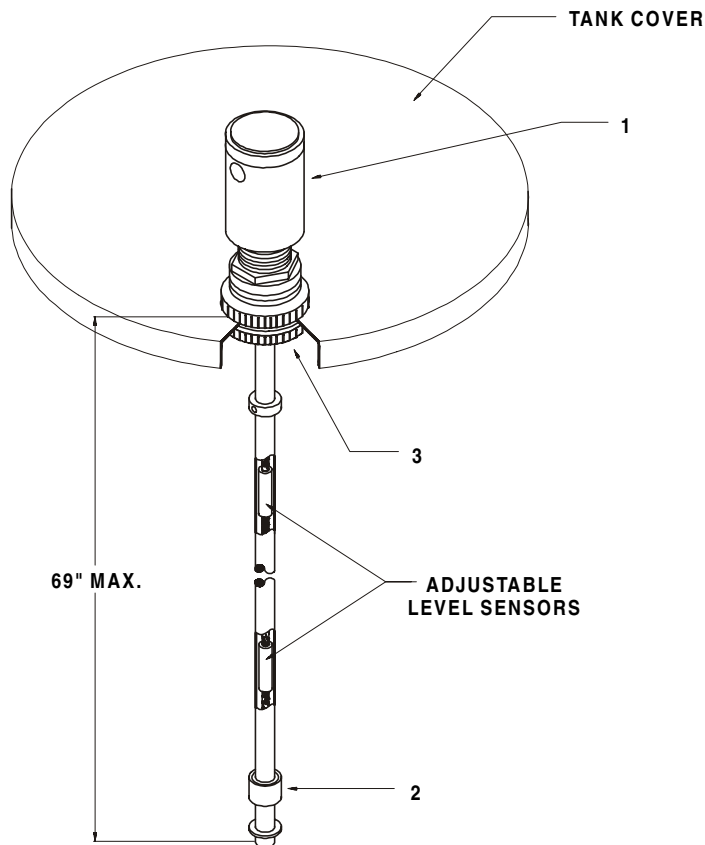

SPECIFICATIONS:

KEY	OPTION	DESCRIPTION
1		CONTROLLER: 115VAC/1P/60 Hz controller with PVC housing, 10 amp relay and 1/2" conduit connection
2	-KK	FLOAT: Low voltage float, polypropylene and encapsulated reed switch
3		TANK ADAPTER: Constructed of gray Sch. 80 PVC with both threaded and slip connections and neoprene gasket

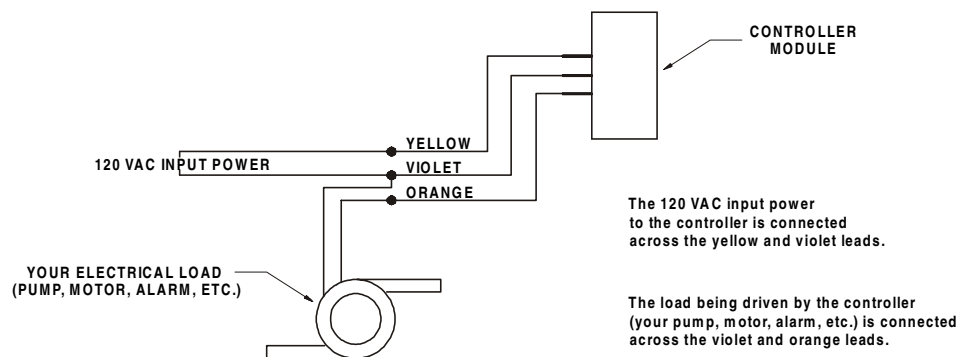

All dimensions are subject to change without notice.