

J.L. WINGERT CO.

P.O. Box 6207 • Garden Grove, CA 92846-6207 / 11800 Monarch Street • Garden Grove, CA 92841-2113
 Phone (714) 379-5519 • Fax (714) 379-5549 ■ Email: customerservice@jllwingert.com
 Northern California Region • Phone (510) 487-5310 ■ Southwest Region • Phone (602) 470-1015
 www.jllwingert.com

MANUFACTURING: Mixers, Bypass Feeders, Filter Feeders, Bromine Feeders, Sample Coolers, Sludge Traps, Separators, Separator Systems, Tank Stands,
 Tank Package Systems, Glycol Feed Systems, Coupon Racks, Control Stations, NEMA Enclosures, Custom Packaged Systems and Specialty Welding

Specification Sheet #102207 Rev. "C" (2/00)

OPTION "-OO" HIGH OR LOW SIDE MOUNT LEVEL SWITCH

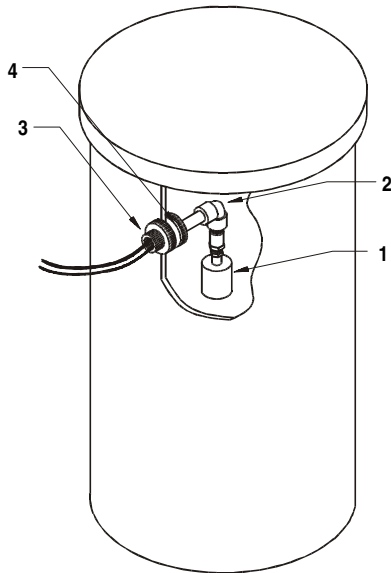

SPECIFICATIONS:

KEY	DESCRIPTION
1	LEVEL SWITCH: Constructed of polypropylene with maximum switch amp load of 10 amps @115V (switch normally open or normally closed by reversing float orientation)
2	ELBOW: Threaded and constructed of Sch. 80 PVC
3	ADAPTER: Constructed of gray Sch. 80 PVC with both threaded and slip connections
4	GASKET: Standard gasket material is neoprene

**NOTE: ALL ELECTRICAL
 WILL HAVE TO COMPLY
 WITH BUILDING CODES**

TYPICAL USE

