

J.L. WINGERT CO.

P.O. Box 6207 • Garden Grove, CA 92846-6207 / 11800 Monarch Street • Garden Grove, CA 92841-2113
 Phone (714) 379-5519 • Fax (714) 379-5549 ■ Email: customerservice@jllwingert.com
 Northern California Region • Phone (510) 487-5310 ■ Southwest Region • Phone (602) 470-1015
 www.jllwingert.com

MANUFACTURING: Mixers, Bypass Feeders, Filter Feeders, Bromine Feeders, Sample Coolers, Sludge Traps, Separators, Separator Systems, Tank Stands,
 Tank Package Systems, Glycol Feed Systems, Coupon Racks, Control Stations, NEMA Enclosures, Custom Packaged Systems and Specialty Welding

Specification Sheet #102201 Rev. "C" (1/00)

PVC/POLYPROPYLENE TANK ADAPTERS

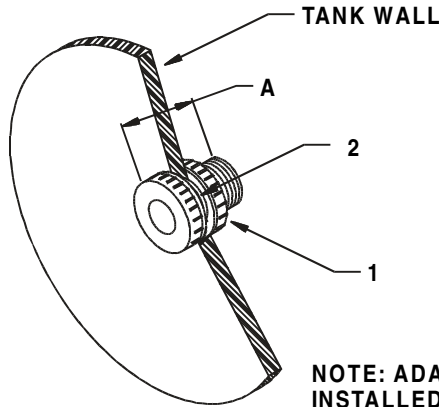

NOTE: ADAPTERS TYPICALLY
 INSTALLED THREADS OUT. ADAPTER
 MAY BE REVERSED FOR SOCKET WELD.

TYPICAL USES

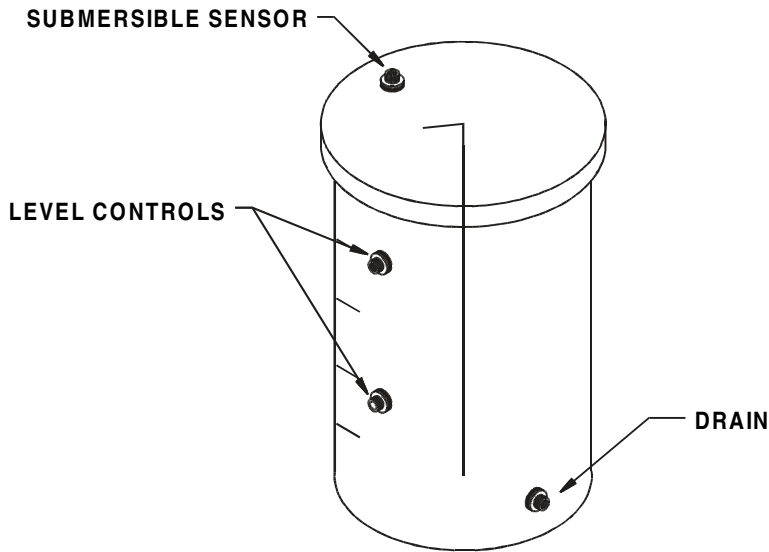

SPECIFICATIONS:

KEY	PART	DESCRIPTION
1	R	1/4" PVC TANK ADAPTER: Constructed of gray Sch. 80 PVC with both threaded and slip connections
	S	1/2" PVC TANK ADAPTER: Constructed of gray Sch. 80 PVC with both threaded and slip connections
	T	3/4" PVC TANK ADAPTER: Constructed of gray Sch. 80 PVC with both threaded and slip connections
	U	1" PVC TANK ADAPTER: Constructed of gray Sch. 80 PVC with both threaded and slip connections
	V	1 1/2" PVC TANK ADAPTER: Constructed of gray Sch. 80 PVC with both threaded and slip connections
	W	2" PVC TANK ADAPTER: Constructed of gray Sch. 80 PVC with both threaded and slip connections
	X	3" PVC TANK ADAPTER: Constructed of gray Sch. 80 PVC with both threaded and slip connections
	FF	1/2" POLYPROPYLENE TANK ADAPTER: Constructed of natural polypropylene with both threaded and slip connections
	HH	3/4" POLYPROPYLENE TANK ADAPTER: Constructed of natural polypropylene with both threaded and slip connections
	JJ	1" POLYPROPYLENE TANK ADAPTER: Constructed of natural polypropylene with both threaded and slip connections
2	I	2" POLYPROPYLENE TANK ADAPTER: Constructed of natural polypropylene with both threaded and slip connections
		GASKET: Standard gasket material is neoprene

DIMENSIONS:

KEY	A
OPTION R	1 1/8"
OPTION S	2"
OPTION T	2"
OPTION U	2"
OPTION V	2 1/4"
OPTION W	2 1/4"
OPTION X	4 5/8"
OPTION FF	2"
OPTION HH	2"
OPTION JJ	2"
OPTION I	2 1/4"