

J.L. WINGERT CO.

P.O. Box 6207 • Garden Grove, CA 92846-6207 / 11800 Monarch Street • Garden Grove, CA 92841-2113
 Phone (714) 379-5519 • Fax (714) 379-5549 ■ Email: customerservice@jllwingert.com
 Northern California Region • Phone (510) 487-5310 ■ Southwest Region • Phone (602) 470-1015
 www.jllwingert.com

MANUFACTURING: Mixers, Bypass Feeders, Filter Feeders, Bromine Feeders, Sample Coolers, Sludge Traps, Separators, Separator Systems, Tank Stands,
 Tank Package Systems, Glycol Feed Systems, Coupon Racks, Control Stations, NEMA Enclosures, Custom Packaged Systems and Specialty Welding

Specification Sheet #102003 Rev. "C" (1/00)

"-3" INSTRUMENT PANEL/NEMA BOX MOUNTING BRACKET

SPECIFICATIONS:

PART	DESCRIPTION
-3	MOUNTING BRACKET: Constructed of 1" carbon steel flat stock painted with water based enamel

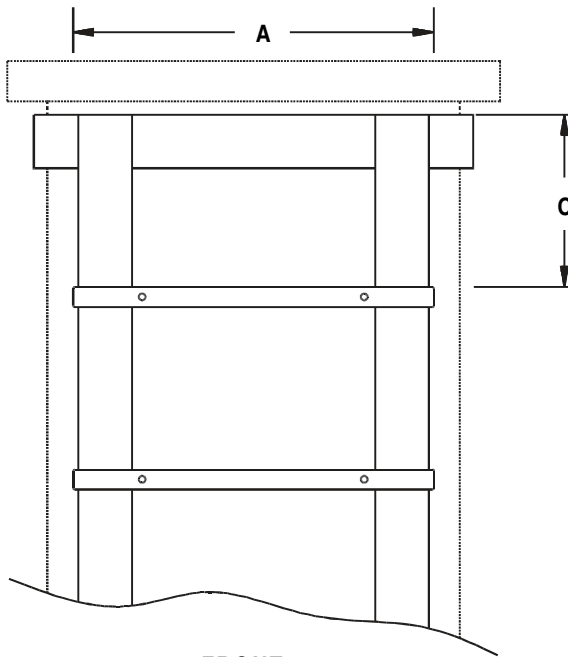

FRONT

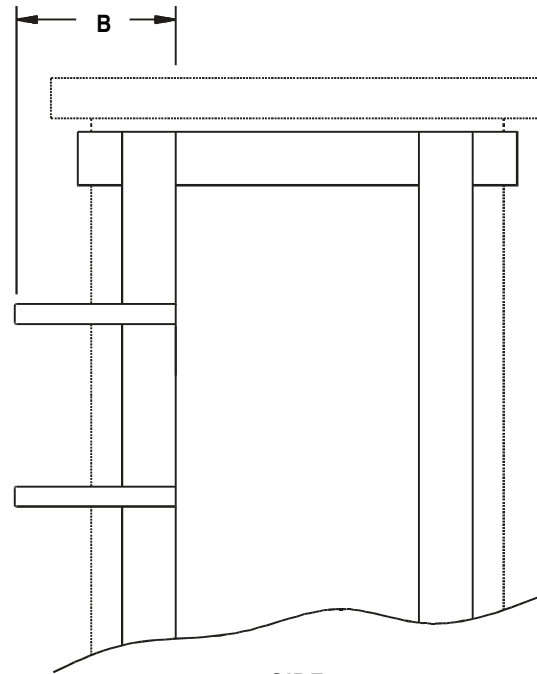

SIDE

DIMENSIONS & WEIGHT:

TANK SIZE	A	B	C	Bracket Weight
15 Gallon	12 3/4"	6 1/4"	5"	3 lbs.
30 Gallon	15"	6 3/4"	5"	3 lbs.
55 Gallon	18"	7 1/4"	5"	4 lbs.
65 Gallon	18 1/16"	7 1/4"	5"	4 lbs.
80 Gallon	20 1/4"	7 1/2"	5"	4 lbs.
100 Gallon	21 3/8"	8"	5"	4 lbs.
150 Gallon	25"	8 3/4"	5"	4 lbs.
200 Gallon	28 1/4"	9 1/2"	5"	5 lbs.
275 Gallon	32 3/8"	10 1/2"	5"	6 lbs.
360 Gallon	37 1/4"	11 1/4"	5"	7 lbs.
500 Gallon	40 1/8"	11 3/4"	5"	7 lbs.

NOTE: Please specify your control box size for bolt pattern when ordering. Refer to price list JLW0810 for Wingert NEMA enclosure dimensions.

Note: All dimensions are +/- 1/8". All weights are approximate. All dimensions are subject to change without notice.