

# J.L. WINGERT CO.

P.O. Box 6207 • Garden Grove, CA 92846-6207 / 11800 Monarch Street • Garden Grove, CA 92841-2113  
 Phone (714) 379-5519 • Fax (714) 379-5549 ■ Email: customerservice@jllwingert.com  
 Northern California Region • Phone (510) 487-5310 ■ Southwest Region • Phone (602) 470-1015  
 www.jllwingert.com

MANUFACTURING: Mixers, Bypass Feeders, Filter Feeders, Bromine Feeders, Sample Coolers, Sludge Traps, Separators, Separator Systems, Tank Stands,  
 Tank Package Systems, Glycol Feed Systems, Coupon Racks, Control Stations, NEMA Enclosures, Custom Packaged Systems and Specialty Welding

Specification Sheet #052202 Rev. "A" (3/99)

## SEPARATOR MOTORIZED PURGE KITS

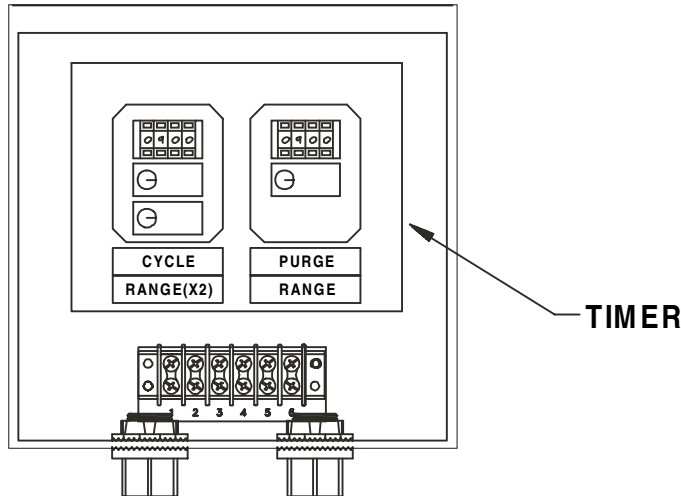

### MODEL NUMBER:

MPK-E-0075	3/4" Motorized Purge Kit and Economy Timer
MPK-E-0150	1 1/2" Motorized Purge Kit and Economy Timer
MPK-E-0200	2" Motorized Purge Kit and Economy Timer
MPK-D-0075	3/4" Motorized Purge Kit and Deluxe Timer
MPK-D-0150	1 1/2" Motorized Purge Kit and Deluxe Timer
MPK-D-0200	2" Motorized Purge Kit and Deluxe Timer

### SPECIFICATIONS:

BALL VALVES	Brass body, stainless steel ball and stem
	600 PSI WOG
	150° F working pressure
ACTUATOR	NEMA 4 enclosure
	115VAC, 1phase, 60 hertz
	8 second cycle
TIMER	115VAC, 1phase, 60 hertz
	DPDT 5amp relay
	Programmable time ranges
WEIGHT	Up to 25 lbs. (11.3 kgs.)

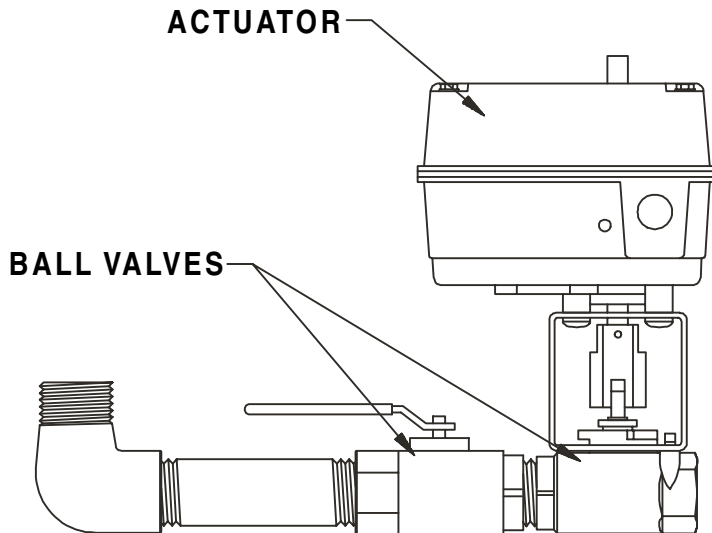

Note: All dimensions are +/- 1/8". All weights are approximate. All dimensions are subject to change without notice.