

J.L. WINGERT CO.

P.O. Box 6207 • Garden Grove, CA 92846-6207 / 11800 Monarch Street • Garden Grove, CA 92841-2113
 Phone (714) 379-5519 • Fax (714) 379-5549 ■ Email: customerservice@jllwingert.com
 Northern California Region • Phone (510) 487-5310 ■ Southwest Region • Phone (602) 470-1015
 www.jllwingert.com

MANUFACTURING: Mixers, Bypass Feeders, Filter Feeders, Bromine Feeders, Sample Coolers, Sludge Traps, Separators, Separator Systems, Tank Stands,
 Tank Package Systems, Glycol Feed Systems, Coupon Racks, Control Stations, NEMA Enclosures, Custom Packaged Systems and Specialty Welding

Specification Sheet #052058 Rev. "B" (3/02)

RT-[]/S RECOVERY TANK SYSTEM

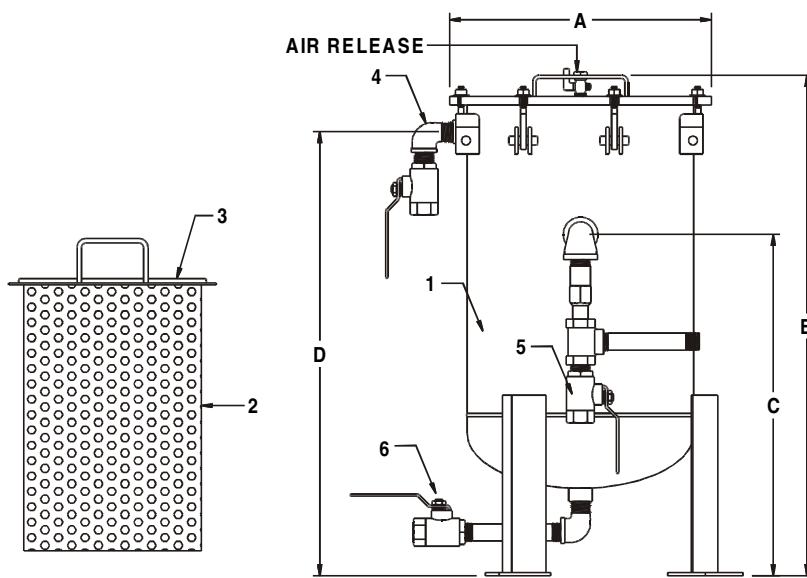

SPECIFICATIONS:

KEY	DESCRIPTION
1	TANK: Fabricated carbon steel vessel, internally epoxy coated, basket support ring and bolt secured lid. Buna-N o-ring, brass pressure/air release and carbon steel handle. Painted with water based enamel.
2	BASKET: 316 SS perforated basket and dual handles
3	FILTER: Napped polyester rated at 25 microns
4	INLET VALVE ASSEMBLY: 3/4" brass ball valve and street ell
5	OUTLET VALVE ASSEMBLY: 3/4" 3 gpm flow control valve, brass flow switch, brass ball valve and street ell
6	DRAIN VALVE: 3/4" brass ball valve, nipple & street ell

TEMPERATURE	200° F (93° C)
PRESSURE	150 psi (10.3 BAR)

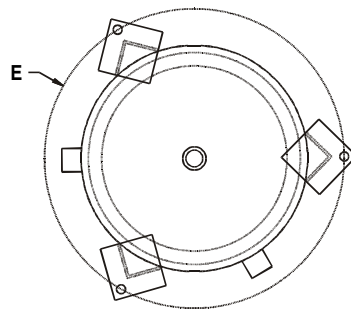

MODEL	RECOMMENDED SEPARATOR SIZE	CAPACITY (GALS /LTRS)	INLET	OUTLET	FILTER VOLUME	A	B	C	D	E	WEIGHT
RT-2/S	1/2" - 1 1/2"	2 / 7.6	3/4"	3/4"	461 cu. in.	9 1/2"	25 1/4"	18 3/16"	22 3/16"	10 1/2"	55 lbs.
RT-5/S	2" - 3"	5 / 18.9	3/4"	3/4"	1,154 cu. in.	14"	25"	19 1/8"	23 1/8"	14 7/8"	85 lbs.
RT-10/S	4" - 20"	10 / 37.9	3/4"	3/4"	2,310 cu. in.	15 3/4"	27"	19 5/8"	25 1/16"	16 7/8"	110 lbs.

Note: All dimensions are +/- 1/8". All weights are approximate. All dimensions are subject to change without notice.