

J.L. WINGERT CO.

P.O. Box 6207 • Garden Grove, CA 92846-6207 / 11800 Monarch Street • Garden Grove, CA 92841-2113

Phone (714) 379-5519 • Fax (714) 379-5549 ■ Email: customerservice@jllwingert.com

Northern California Region • Phone (510) 487-5310 ■ Southwest Region • Phone (602) 470-1015

www.jllwingert.com

MANUFACTURING: Mixers, Bypass Feeders, Filter Feeders, Bromine Feeders, Sample Coolers, Sludge Traps, Separators, Separator Systems, Tank Stands, Tank Package Systems, Glycol Feed Systems, Coupon Racks, Control Stations, NEMA Enclosures, Custom Packaged Systems and Specialty Welding

Specification Sheet #052054 Rev. "D" (05/05)

"CT" CLEAN TOWER SYSTEMS

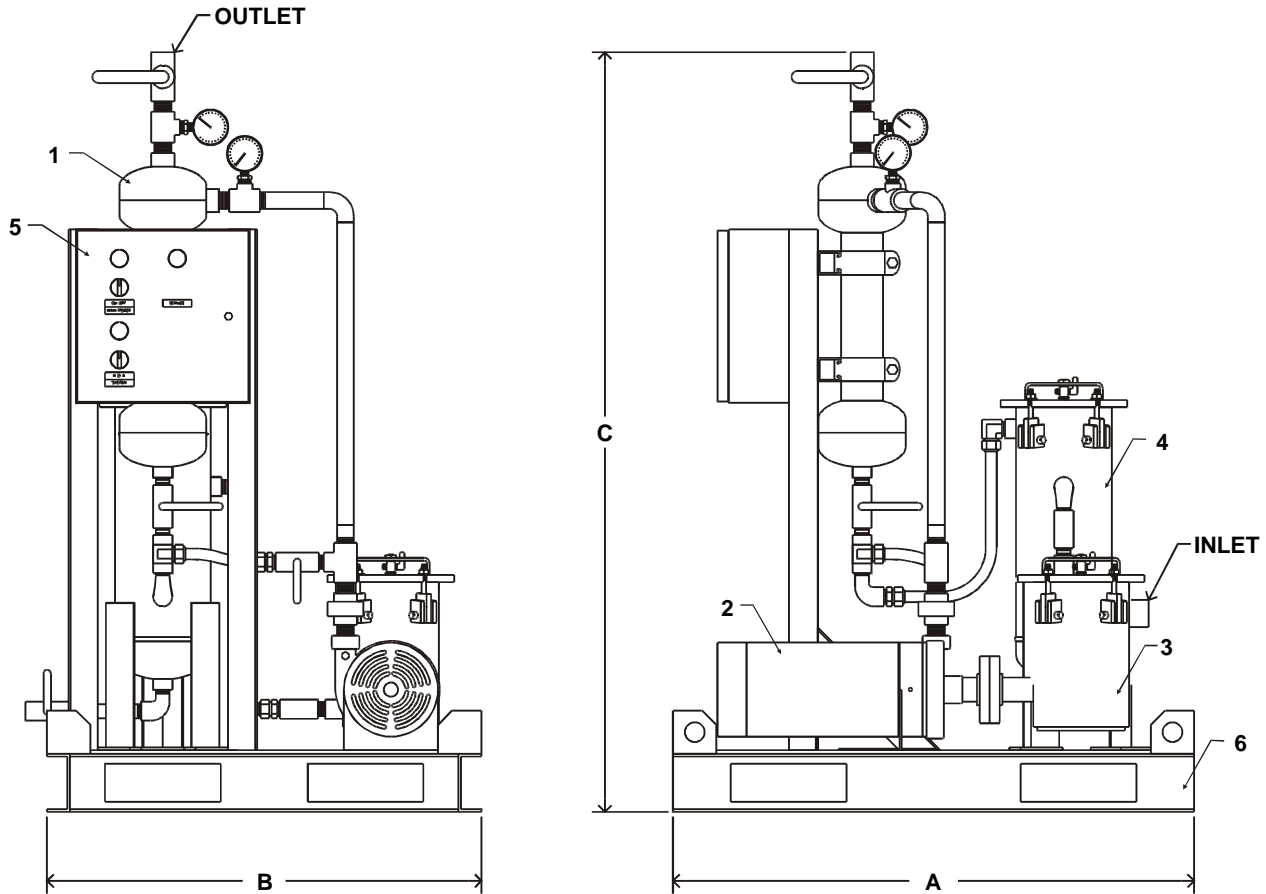

SPECIFICATIONS:

KEY	DESCRIPTION
1	SEPARATOR: Constructed from carbon steel with water based enamel paint
2	PUMP: 230VAC, 3 phase, 60 Hz, TEFC motor with cast iron pump head, standard fit and bronze impeller. (460V/3/60 available upon request)
3	PUMP STRAINER: Fabricated carbon steel housing, internally epoxy coated, and 316 stainless steel perforated basket
4	RECOVERY TANK: Fabricated carbon steel housing, internally epoxy coated, 316 stainless steel perforated basket and 25 micron napped poly bag with handle (OPTIONAL: motorized purge kit in place of standard recovery)
5	CONTROL PANEL: 230VAC, 3 phase, 60 hertz main power, NEMA 4 control panel, transformer, motor starter, motor overload and recovery tank relay with 115V control power, CSA approved. (460V/3/60 available upon request)
6	SKID: Fabricated carbon steel skid, lifting lugs, forklift slots and control panel bracket with water based enamel paint

Note: "CT" systems are wired 230 VAC, 3 phase, 60 hertz standard. Please confirm voltage at time of order.

MODEL	FLOW GPM (M ³ /M)	INLET	OUTLET	HP	A	B	C	WEIGHT
CT-0038	38 (.2)	1.25"	1"	2	36"	30"	50"	595 lbs.
CT-0065	65 (.3)	2"	1 1/2"	3	36"	30"	56"	610 lbs.
CT-0100	100 (.4)	2"	1 1/2"	5	36"	30"	56"	630 lbs.
CT-0160	160 (.6)	3"	2 1/2"	7.5	48"	36"	53"	780 lbs.
CT-0200	200 (.8)	3"	3"	7.5	48"	36"	55"	830 lbs.
CT-0280	280 (1)	3"	3"	10	48"	36"	55"	835 lbs.
CT-0450	450 (1.7)	4"	4"	15	66"	48"	62"	1,550 lbs.
CT-0550	550 (2)	4"	4"	20	66"	48"	62"	1,790 lbs.
CT-0850	850 (3.2)	6"	6"	30	66"	48"	62"	2,030 lbs.
CT-1200	1,200 (4.5)	6"	6"	40	66"	48"	69"	2,190 lbs.

NOTE: All 3" and above are flanged

Note: All dimensions are +/- 1/8". All weights are approximate. All dimensions are subject to change without notice.