

# J.L. WINGERT CO.

P.O. Box 6207 • Garden Grove, CA 92846-6207 / 11800 Monarch Street • Garden Grove, CA 92841-2113

Phone (714) 379-5519 • Fax (714) 379-5549 ■ Email: customerservice@jllwingert.com

Northern California Region • Phone (510) 487-5310 ■ Southwest Region • Phone (602) 470-1015

www.jllwingert.com

MANUFACTURING: Mixers, Bypass Feeders, Filter Feeders, Bromine Feeders, Sample Coolers, Sludge Traps, Separators, Separator Systems, Tank Stands, Tank Package Systems, Glycol Feed Systems, Coupon Racks, Control Stations, NEMA Enclosures, Custom Packaged Systems and Specialty Welding

Specification Sheet #052012 Rev. "B" (2/01)

## SEPARATOR WALL MOUNT BRACKETS

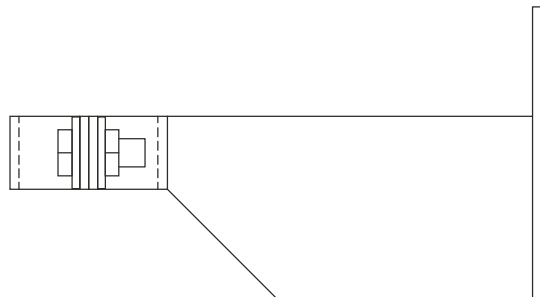
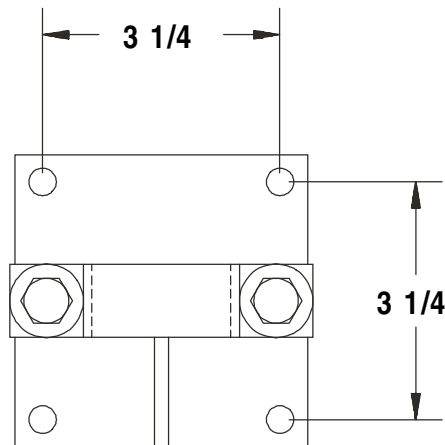
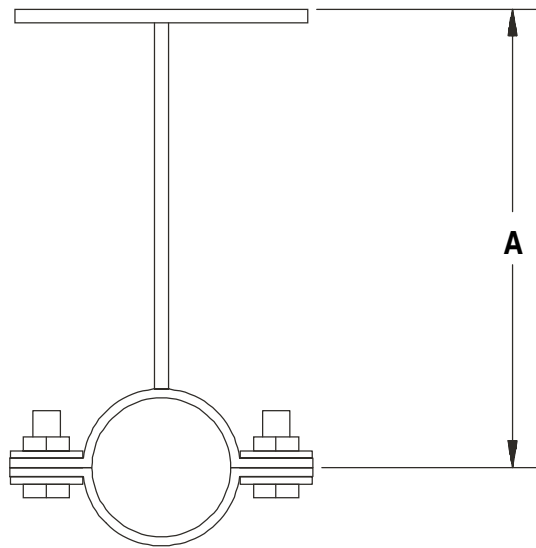

### SPECIFICATIONS:

Wall mount brackets are constructed from carbon steel and painted with water based enamel. All hardware is plated steel.

### DIMENSIONS & WEIGHT:

MODEL	A	WEIGHT
BM-0050	6 1/4"	3 lbs.
BM-0075	6 1/2"	3 lbs.
BM-0100	6 3/4"	3 lbs.
BM-0125	5 3/8"	4 lbs.
BM-0150	5 3/8"	4 lbs.
BM-0200	8 3/8"	4 lbs.
BM-0250	8 3/8"	4 lbs.
BM-0300	7 3/8"	5 lbs.

Note: All dimensions are +/- 1/8". All weights are approximate. All dimensions are subject to change without notice.