

J.L. WINGERT CO.

P.O. Box 6207 • Garden Grove, CA 92846-6207 / 11800 Monarch Street • Garden Grove, CA 92841-2113
 Phone (714) 379-5519 • Fax (714) 379-5549 ■ Email: customerservice@jllwingert.com
 Northern California Region • Phone (510) 487-5310 ■ Southwest Region • Phone (602) 470-1015
 www.jllwingert.com

MANUFACTURING: Mixers, Bypass Feeders, Filter Feeders, Bromine Feeders, Sample Coolers, Sludge Traps, Separators, Separator Systems, Tank Stands,
 Tank Package Systems, Glycol Feed Systems, Coupon Racks, Control Stations, NEMA Enclosures, Custom Packaged Systems and Specialty Welding

Specification Sheet #042002 Rev. "D" (12/99)

MODEL SC-1-A-600 / SC-1-B-600

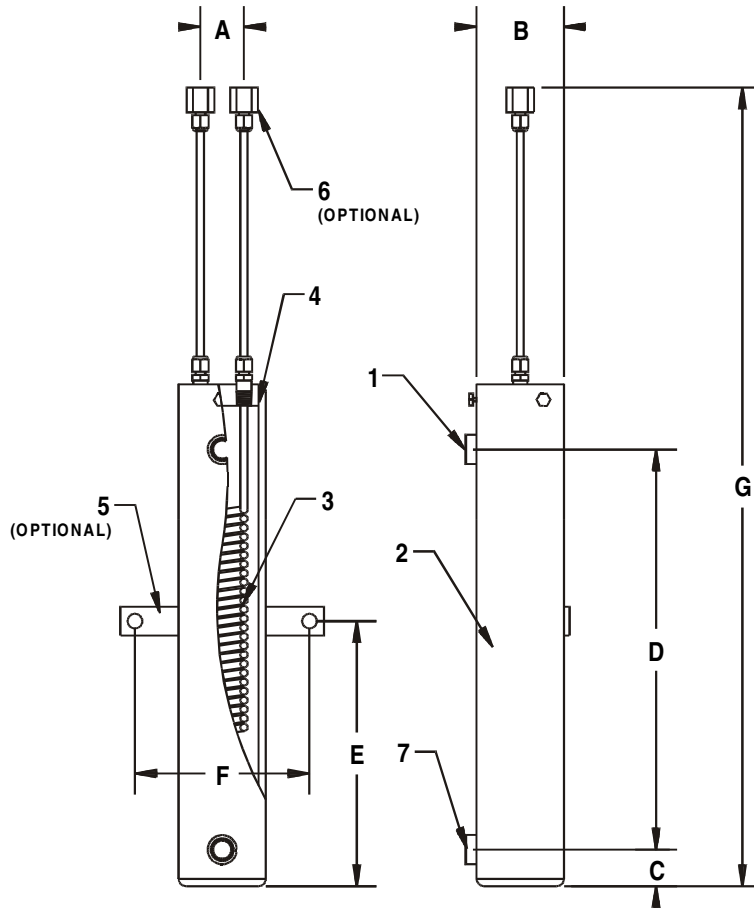

SPECIFICATIONS:

KEY	PART	DESCRIPTION
1		COOLING WATER INLET: 1/2" FNPT
2		BODY: Sch. 40 steel pipe and C1215 end plugs
3	1024	COIL & PLUG: 1/4" x 20ft. Inconel 600 coil and C1215 plug
4	1025	O-RING: Replacement Buna-N O-Ring for coil and plug assembly
5	MB	MOUNTING BRACKET: Optional mild steel mounting bracket welded to shell (SC-1-B-600/MB model only)
6	1028	FITTINGS: Optional 1/4" FNPT 316 stainless steel connection fittings (standard on SC-1-B-600 model)
7		COOLING WATER OUTLET: 1/2" FNPT

OPERATING PARAMETERS:	SAMPLE LIQUID	COOLING WATER
Maximum Temperature	600° F (315° C)	250° F (120° C)
Maximum Pressure	1500 PSI	200 PSI

DIMENSIONS, WEIGHT & CUBE:

KEY	SC-1-A-600	SC-1-A-600/MB	SC-1-B-600	SC-1-B-600/MB
A	1 1/2"	1 1/2"	1 1/2"	1 1/2"
B	3"	3"	3"	3"
C	1 3/8"	1 3/8"	1 3/8"	1 3/8"
D	13 3/4"	13 3/4"	13 3/4"	13 3/4"
E	N/A	7 1/4"	N/A	7 1/4"
F	N/A	5 1/2"	N/A	5 1/2"
G	27"	27"	28"	28"
Weight	16 lbs. approx.	16 lbs. approx.	16 lbs. approx.	16 lbs. approx.
Cube	5" x 5" x 27"	5" x 5" x 27"	5" x 5" x 28"	5" x 5" x 28"

Note: All dimensions are +/- 1/8". All weights are approximate. All dimensions are subject to change without notice.