

# J.L. WINGERT CO.

P.O. Box 6207 • Garden Grove, CA 92846-6207 / 11800 Monarch Street • Garden Grove, CA 92841-2113  
 Phone (714) 379-5519 • Fax (714) 379-5549 ■ Southwest Region • Phone (602) 470-1015  
 30998 Huntwood Avenue, Unit 105 • Hayward, CA 94544-7033 • Phone (510) 487-5310 • Fax (510) 487-5137  
 On the Internet: [www.jlwingert.com](http://www.jlwingert.com) • Email: [customerservice@jlwingert.com](mailto:customerservice@jlwingert.com)

MANUFACTURING: Mixers, Bypass Feeders, Filter Feeders, Bromine Feeders, Sample Coolers, Sludge Traps, Separators, Separator Systems, Tank Stands,  
 Tank Package Systems, Glycol Feed Systems, Coupon Racks, Control Stations, NEMA Enclosures, Custom Packaged Systems and Specialty Welding

Specification Sheet #032030 Rev. "A" (12/02)

## FILTER BAG KIT (3009, 3010 & 3080)

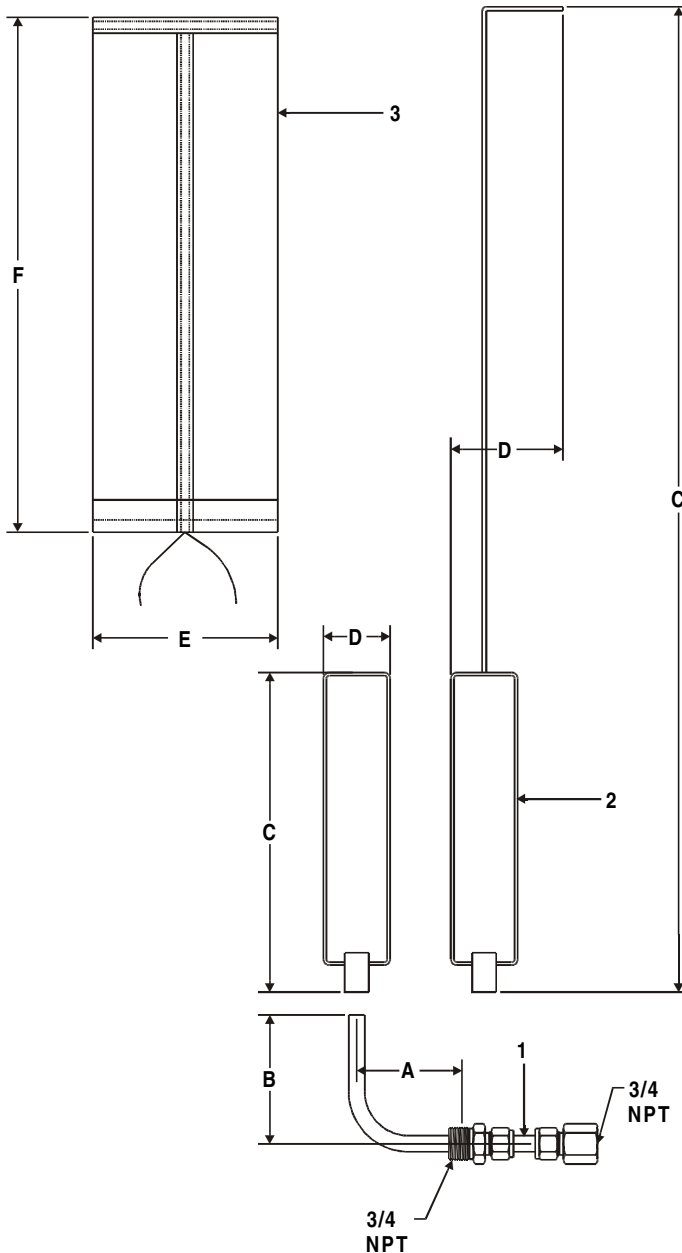

### SPECIFICATIONS:

KEY	PART	FITS	DESCRIPTION
1	3084	3009	SUPPORT TUBE: 1/2" OD stainless steel support tube with brass connectors
	3085	3010, 3080	
2	3083	3009, 3010	BAG SUPPORT: 1/8" carbon steel bag support wire with carbon steel guide
	3101	3080	
3	3070	ALL	FILTER BAGS: Box of six (6) replacement draw string filter bags, 30-50 micron nominal
MAX TEMP.:		200° F (93° C)	
MAX. PSID:		10PSI (0.7bar)	

### DIMENSIONS, WEIGHT & CUBE:

KEY	3009	3010	3080
A	3"	5"	5"
B	4"	4"	4"
C	10"	10"	30 5/8"
D	2"	2"	3 1/2"
E	5 3/4"	5 3/4"	5 3/4"
F	16"	16"	16"
WEIGHT	5 lbs. approx.	5 lbs. approx.	8 lbs. approx.
CUBE	3" X 3" X 14"	3" X 3" X 14"	5" X 5" X 36"

Note: All dimensions are +/- 1/8". All weights are approximate. All dimensions are subject to change without notice.