

J.L. WINGERT CO.

P.O. Box 6207 • Garden Grove, CA 92846-6207 / 11800 Monarch Street • Garden Grove, CA 92841-2113
 Phone (714) 379-5519 • Fax (714) 379-5549 ■ Southwest Regional Sales Office Phone (602) 470-1015
 30998 Huntwood Avenue, Unit 105 • Hayward, CA 94544-7033 • Phone (510) 487-5310 • Fax (510) 487-5137

On the Internet: www.jlwingert.com • Email: customerservice@jlwingert.com

MANUFACTURING: Mixers, Bypass Feeders, Filter Feeders, Sample Coolers, Sludge Traps, Separators, Tank Stands,
 Tank Package Systems, Glycol Feed Systems, Coupon Racks, Custom Packaged Systems and Specialty Welding

Specification Sheet #022065 Rev. "B" (11/99)

MODEL 2056 / 2057 AIR FILTER REGULATOR, LUBRICATOR

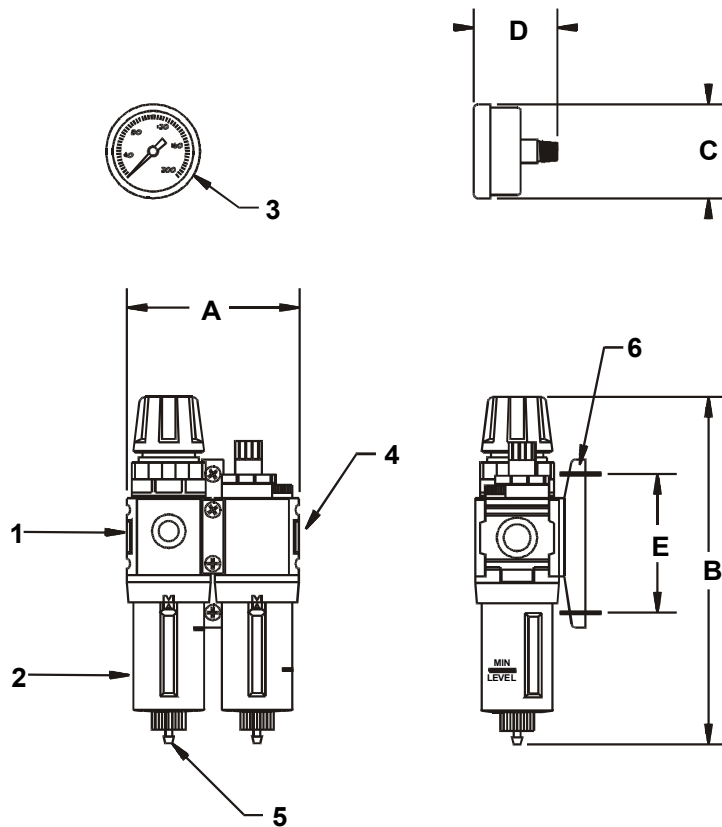

SPECIFICATIONS:

KEY	PART	DESCRIPTION
1	BODY	Cast iron
2	BOWL	Clear plastic bowl & bowl guard
3	GAUGE (2056)	1/8" steel drawn 0-200 PSI (back tapped)
	GAUGE (2057)	1/4" steel drawn 0-200 PSI (back tapped)
4	PORT SIZES (2056)	1/4" FNPT, gauge port 1/8" FNPT
	PORT SIZES (2057)	1/4" FNPT, gauge port 1/4" FNPT
5	DRAIN	Manual, 5/32" I.D. hose connector
6	MOUNT BRACKET	Carbon steel wall mounting bracket

DIMENSIONS, WEIGHT & CUBE:

KEY	2056	2057
A	3.31"	4.72"
B	6.46"	10.00"
C	1.50"	1.75"
D	1.75"	2.25"
E	3.12"	3.25"
Weight	1.70 lbs. approx.	3.40 lbs. approx.
Cube	4" X 6" X 7"	5" X 7" X 10"

OPERATING PARAMETERS:	2056	2057
Max. Temperature	125° F (51.7° C)	150° F (62° C)
Max. Pressure	150 psi (10.3 bar)	150 psi (10.3 bar)
Max. CFM	40	88

Note: All dimensions are +/- 1/8". All weights are approximate. All dimensions are subject to change without notice.