

J.L. WINGERT CO.

P.O. Box 6207 • Garden Grove, CA 92846-6207 / 11800 Monarch Street • Garden Grove, CA 92841-2113
 Phone (714) 379-5519 • Fax (714) 379-5549 ■ Southwest Region • (602) 470-1015
 30998 Huntwood Avenue, Unit 105 • Hayward, CA 94544-7033 • Phone (510) 487-5310 • Fax (510) 487-5137
 On the Internet: www.jlwingert.com • Email: customerservice@jlwingert.com

MANUFACTURING: Mixers, Bypass Feeders, Filter Feeders, Bromine Feeders, Sample Coolers, Sludge Traps, Separators, Separator Systems, Tank Stands,
 Tank Package Systems, Glycol Feed Systems, Coupon Racks, Control Stations, NEMA Enclosures, Custom Packaged Systems and Specialty Welding

Specification Sheet #022063 Rev. "B" (11/99)

MODEL 2053 / 2060 AIR MIST LUBRICATOR

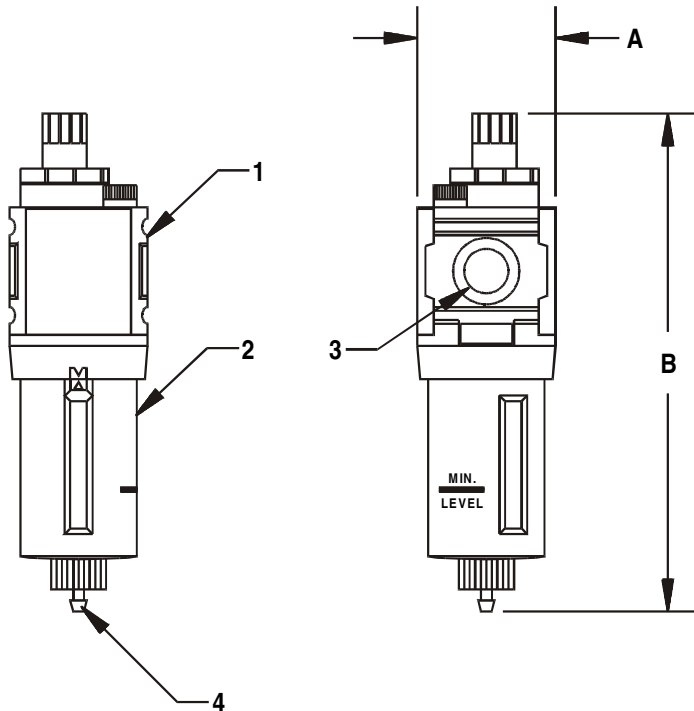

SPECIFICATIONS:

KEY	PART	DESCRIPTION
1	BODY	Cast iron
2	BOWL	Clear plastic bowl & bowl guard
3	PORT SIZES	1/4" FNPT
4	DRAIN	Manual 5/32" I.D. hose connector

DIMENSIONS, WEIGHT & CUBE:

KEY	2052	2059
A	2.36"	1.58"
B	8.25"	5.65"
Weight	1.40 lbs. approx.	.80 lbs. approx.
Cube	3" X 3" X 9"	2" X 2" X 6"

OPERATING PARAMETERS:

	2052	2059
Max. Temperature	125° F (51.7° C)	125° F (51.7° C)
Max. Pressure	150 psi (10.3 bar)	150 psi (10.3 bar)
Max. CFM	88	57

Note: All dimensions are +/- 1/8". All weights are approximate. All dimensions are subject to change without notice.