

J.L. WINGERT CO.

P.O. Box 6207 • Garden Grove, CA 92846-6207 / 11800 Monarch Street • Garden Grove, CA 92841-2113
 Phone (714) 379-5519 • Fax (714) 379-5549 ■ Southwest Region • Phone (602) 470-1015
 30998 Huntwood Avenue, Unit 105 • Hayward, CA 94544-7033 • Phone (510) 487-5310 • Fax (510) 487-5137
 On the Internet: www.jlwingert.com • Email: customerservice@jlwingert.com

MANUFACTURING: Mixers, Bypass Feeders, Filter Feeders, Bromine Feeders, Sample Coolers, Sludge Traps, Separators, Separator Systems, Tank Stands,
 Tank Package Systems, Glycol Feed Systems, Coupon Racks, Control Stations, NEMA Enclosures, Custom Packaged Systems and Specialty Welding

Specification Sheet #022062 Rev. "B" (11/99)

MODEL 2052 / 2059 AIR REGULATOR W/ PRESSURE GAUGE

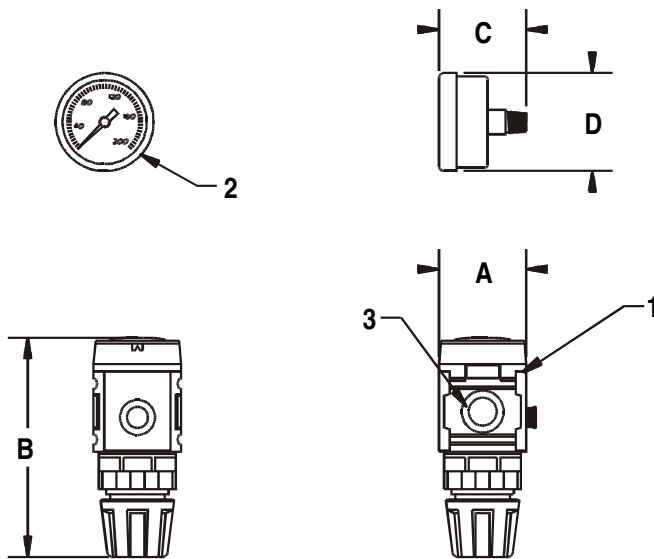

SPECIFICATIONS:

KEY	PART	DESCRIPTION
1	BODY	Cast iron
2	GAUGE (2052)	1/8" steel drawn 0-200 PSI (back tapped)
	GAUGE (2059)	1/4" steel drawn 0-200 PSI (back tapped)
3	PORT SIZES (2052)	1/4" FNPT, gauge port 1/8" FNPT
	PORT SIZES (2059)	1/4" FNPT, gauge port 1/4" FNPT

DIMENSIONS, WEIGHT & CUBE:

KEY	2052	2059
A	2.36"	1.58"
B	5.40"	3.94"
C	1.50"	1.75"
D	1.75"	2.25"
Weight	1.80 lbs. approx	.90 lbs. approx.
Cube	3" X 4" X 6"	2" X 4" X 4"

OPERATING PARAMETERS:	2052	2059
Max. Temperature	175° F (79.4° C)	175° F (79.4° C)
Max. Pressure	300 psi (20.7 bar)	300 psi (20.7 bar)
Max. CFM	104	40

Note: All dimensions are +/- 1/8". All weights are approximate. All dimensions are subject to change without notice.