

# J.L. WINGERT CO.

P.O. Box 6207 • Garden Grove, CA 92846-6207 / 11800 Monarch Street • Garden Grove, CA 92841-2113  
 Phone (714) 379-5519 • Fax (714) 379-5549 ■ Southwest Region • Phone (602) 470-1015  
 30998 Huntwood Avenue, Unit 105 • Hayward, CA 94544-7033 • Phone (510) 487-5310 • Fax (510) 487-5137  
 On the Internet: [www.jlwingert.com](http://www.jlwingert.com) • Email: [customerservice@jlwingert.com](mailto:customerservice@jlwingert.com)

MANUFACTURING: Mixers, Bypass Feeders, Filter Feeders, Bromine Feeders, Sample Coolers, Sludge Traps, Separators, Separator Systems, Tank Stands,  
 Tank Package Systems, Glycol Feed Systems, Coupon Racks, Control Stations, NEMA Enclosures, Custom Packaged Systems and Specialty Welding

Specification Sheet #022003 Rev. "D" (6/00)

## MODEL A11-X-[H/PRP/A] / A12-X-[H/PRP/A]

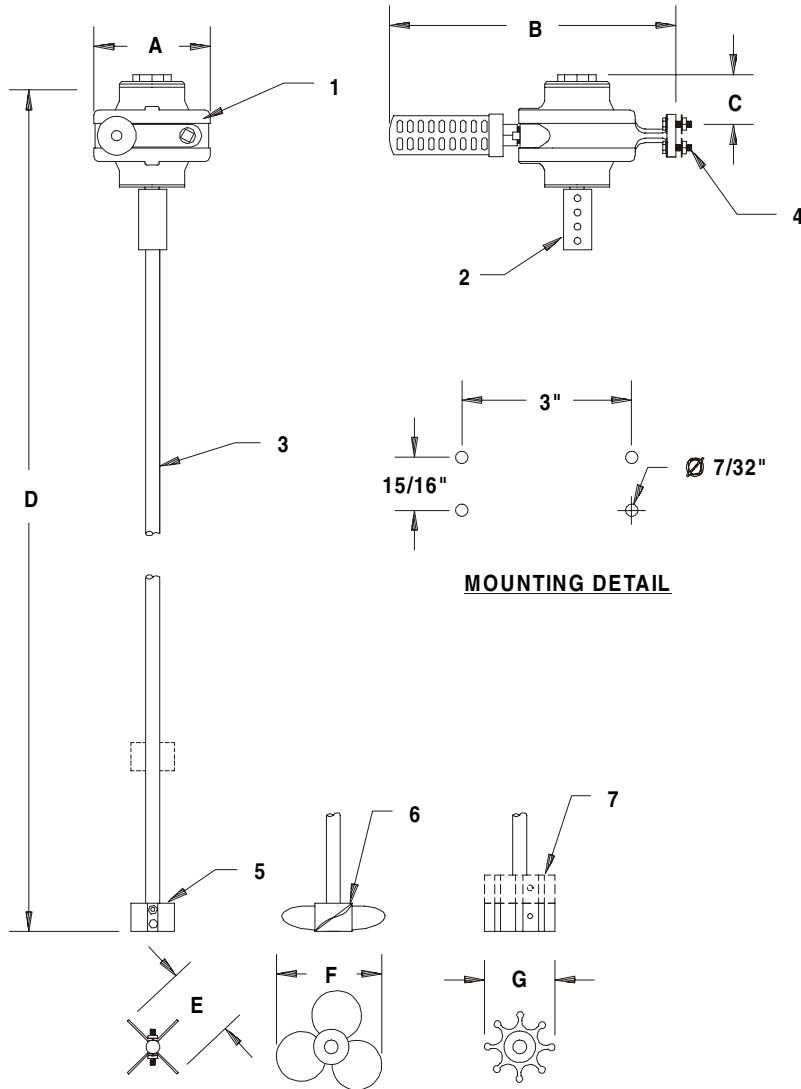

### SPECIFICATIONS:

KEY	PART	DESCRIPTION
1	2080	MOTOR: 1/4-1/3 HP, CCW, fully sealed cast iron casing, with precision sealed bearings
2	2031	COUPLING: 1/2" x 1/2" bored brass coupling with stainless steel set screws
3	0315/34	SHAFT: 1/2" D x 34" L, 304 stainless steel shaft, prepped for impellers / propellers
	0315	SHAFT: 1/2" D x 36" L, 304 stainless steel shaft, prepped for impellers / propellers
4	0349	MOUNT: Plated steel mounting hardware
5	0265	[H] SS IMPELLER: 304 stainless steel 2 hole impellers with mounting hardware
6	0269	[PRP] PROPELLER: 316 stainless steel, 1/2" bore marine style propeller
7	0263	[A] NEOPRENE IMPELLER: Medium neoprene impeller, 1/2" bore with brass / copper hub
	0264	[A] NEOPRENE IMPELLER: Large neoprene impeller, 1/2" bore with brass / copper hub

### DIMENSIONS, WEIGHT & CUBE:

KEY	A11-X-[ ]	A12-X-[ ]
A	4"	4"
B	10 3/4"	10 3/4"
C	1 1/2"	1 1/2"
D	41 1/4"	41 1/4"
E	2 3/8" diameter	2 3/8" diameter
F	4" diameter	4" diameter
G	2 5/8" diameter	2 5/8" diameter
Weight	19 lbs. approx.	20 lbs. approx.
Cube	10 3/8" X 12 3/8" X 36"	

MOTOR DATA:	A11-X-[ ]	A12-X-[ ]
CFM	9	11
PSI	40	43

Note: All dimensions are +/- 1/8". All weights are approximate. All dimensions are subject to change without notice.