

J.L. WINGERT CO.

P.O. Box 6207 • Garden Grove, CA 92846-6207 / 11800 Monarch Street • Garden Grove, CA 92841-2113
 Phone (714) 379-5519 • Fax (714) 379-5549 ■ Southwest Region • Phone (602) 470-1015
 30998 Huntwood Avenue, Unit 105 • Hayward, CA 94544-7033 • Phone (510) 487-5310 • Fax (510) 487-5137

On the Internet: www.jlwingert.com • Email: customerservice@jlwingert.com

MANUFACTURING: Mixers, Bypass Feeders, Filter Feeders, Sample Coolers, Sludge Traps, Separators, Tank Stands,
 Tank Package Systems, Glycol Feed Systems, Coupon Racks, Custom Packaged Systems and Specialty Welding

Specification Sheet #022001 Rev. "D" (6/00)

MODEL A11-B-[H/PRP/A] / A12-B-[H/PRP/A]

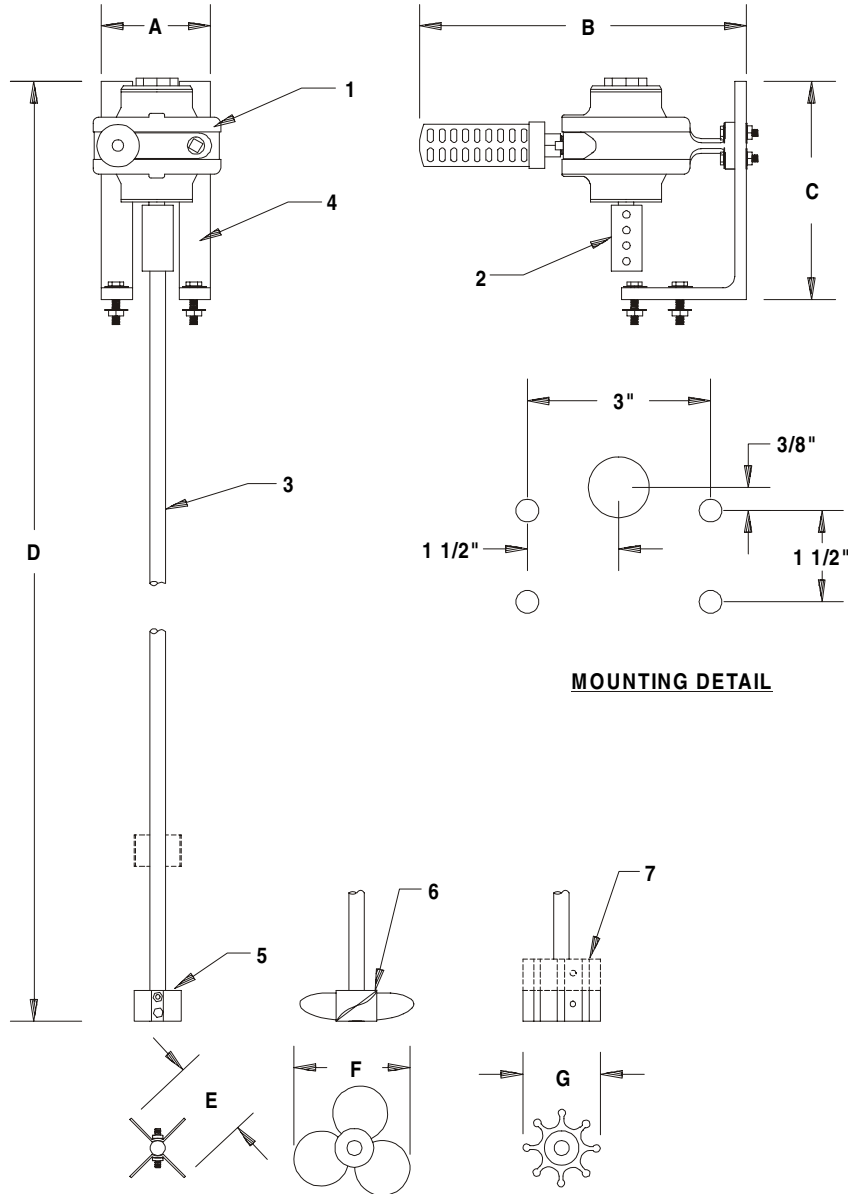

SPECIFICATIONS:

KEY	PART	DESCRIPTION
1	2080	MOTOR: 1/4-1/3 HP, CCW, fully sealed cast iron casing, with precision sealed bearings
2	2031	COUPLING: 1/2" x 1/2" bored brass coupling with stainless steel set screws
3	0315/34	SHAFT: 1/2" D x 34" L, 304 stainless steel shaft, prepped for impellers / propellers
	0315	SHAFT: 1/2" D x 36" L, 304 stainless steel shaft, prepped for impellers / propellers
4	2028	MOUNT: 3/8" steel angle bracket with plated steel hardware
5	0265	[H] SS IMPELLER: 304 stainless steel 2 hole impellers with mounting hardware
6	0269	[PRP] PROPELLER: 316 stainless steel, 1/2" bore marine style propeller
7	0263	[A] NEOPRENE IMPELLER: Medium neoprene impeller, 1/2" bore with brass / copper hub
	0264	[A] NEOPRENE IMPELLER: Large neoprene impeller, 1/2" bore with brass / copper hub

DIMENSIONS, WEIGHT & CUBE:

KEY	A11-B-[]	A12-B-[]
A	4"	4"
B	10 1/4"	10 1/4"
C	7"	7"
D	41 1/4"	41 1/4"
E	2 3/8" diameter	2 3/8" diameter
F	4" diameter	4" diameter
G	2 5/8" diameter	2 5/8" diameter
Weight	19 lbs. approx.	20 lbs. approx.
Cube	10 3/8" X 12 3/8" X 36"	

MOTOR DATA:	A11-B-[]	A12-B-[]
CFM	9	11
PSI	40	43

Note: All dimensions are +/- 1/8". All weights are approximate. All dimensions are subject to change without notice.