

J.L. WINGERT CO.

P.O. Box 6207 • Garden Grove, CA 92846-6207 / 11800 Monarch Street • Garden Grove, CA 92841-2113
 Phone (714) 379-5519 • Fax (714) 379-5549 ■ Southwest Region • Phone (602) 470-1015
 30998 Huntwood Avenue, Unit 105 • Hayward, CA 94544-7033 • Phone (510) 487-5310 • Fax (510) 487-5137
 On the Internet: www.jlwingert.com • Email: customerservice@jlwingert.com

MANUFACTURING: Mixers, Bypass Feeders, Filter Feeders, Bromine Feeders, Sample Coolers, Sludge Traps, Separators, Separator Systems, Tank Stands,
 Tank Package Systems, Glycol Feed Systems, Coupon Racks, Control Stations, NEMA Enclosures, Custom Packaged Systems and Specialty Welding

Specification Sheet #012214 Rev. "E" (6/00)

MODEL VT-3-TE-PRP / VT-4-TE-PRP

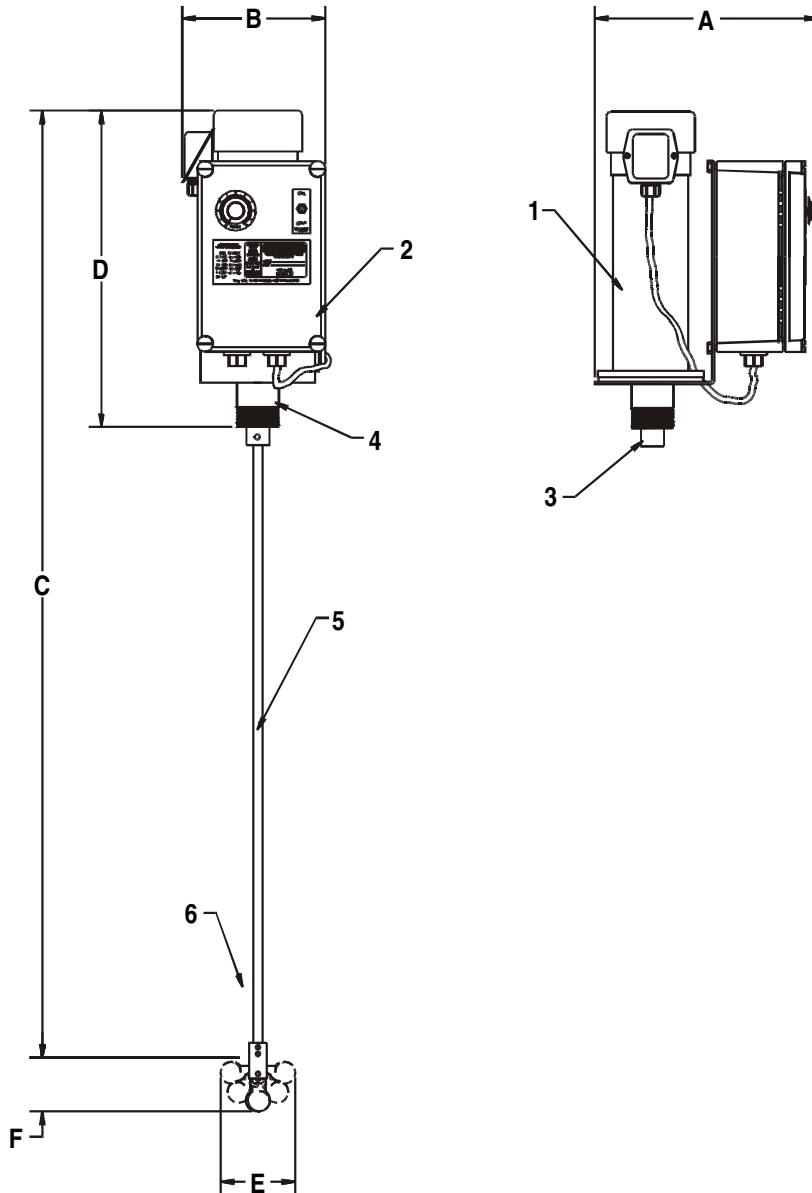

SPECIFICATIONS:

KEY	PART	DESCRIPTION
1	0432-A	MOTOR: 1/2 HP, TEFC, 100 to 1725 RPM
	0433-A	MOTOR: 1HP, TEFC, 100 to 1725 RPM
2	0440-A	SPEED CONTROLLER: 17:1, 115V speed controller
3	0253	COUPLING: 1/2" x 1/2" bored brass coupling with stainless set screws
	0254	COUPLING: 1/2" x 5/8" bored brass coupling with stainless set screws
4	0606	MOUNT: 2" NPT thread mount for steel drum mixing, all hardware is plated steel
5	0315	SHAFT: 1/2" D x 36" L, 304 stainless steel shaft, prepped for collapsible propeller
	0316/44	SHAFT: 5/8" D x 44" L, 304 stainless steel shaft, prepped for collapsible propeller
6	0354-1	[PRP] PROPELLER: 316 stainless steel marine style collapsible 1/2" bore propeller with stainless steel set screw
	0354	[PRP] PROPELLER: 316 stainless steel marine style collapsible 5/8" bore propeller with stainless steel set screw

NOTE: All replacement parts are based on standard mixer model number

DIMENSIONS, WEIGHT & CUBE:

KEY	VT-3-TE-PRP	VT-4-TE-PRP
A	10 1/2"	10 1/2"
B	8 1/2"	8 1/2"
C	48 3/4"	60 3/4"
D	11 1/4"	15 1/4"
E	4" diameter	4" diameter
F	3"	3"
Weight	30 lbs. approx.	43 lbs. approx.
Cube	10 3/8" X 12 3/8" X 36"	10 3/8" X 12 3/8" X 44"

MOTOR DATA:	VT-3-TE-PRP	VT-4-TE-PRP
Voltage	90 VDC	90 VDC
Full Load Amps	5.5	10.9
Service Factor	1.0	1.0
Insulation Class	F	F

Note: All dimensions are +/- 1/8". All weights are approximate. All dimensions are subject to change without notice.