

J.L. WINGERT CO.

P.O. Box 6207 • Garden Grove, CA 92846-6207 / 11800 Monarch Street • Garden Grove, CA 92841-2113
 Phone (714) 379-5519 • Fax (714) 379-5549 ■ Southwest Region • Phone (602) 470-1015
 30998 Huntwood Avenue, Unit 105 • Hayward, CA 94544-7033 • Phone (510) 487-5310 • Fax (510) 487-5137
 On the Internet: www.jlwingert.com • Email: customerservice@jlwingert.com

MANUFACTURING: Mixers, Bypass Feeders, Filter Feeders, Bromine Feeders, Sample Coolers, Sludge Traps, Separators, Separator Systems, Tank Stands,
 Tank Package Systems, Glycol Feed Systems, Coupon Racks, Control Stations, NEMA Enclosures, Custom Packaged Systems and Specialty Welding

Specification Sheet #012212 Rev. "E" (6/00)

MODEL VX-3-TE-[H/PRP/A] / VX-4-TE-[H/PRP/A]

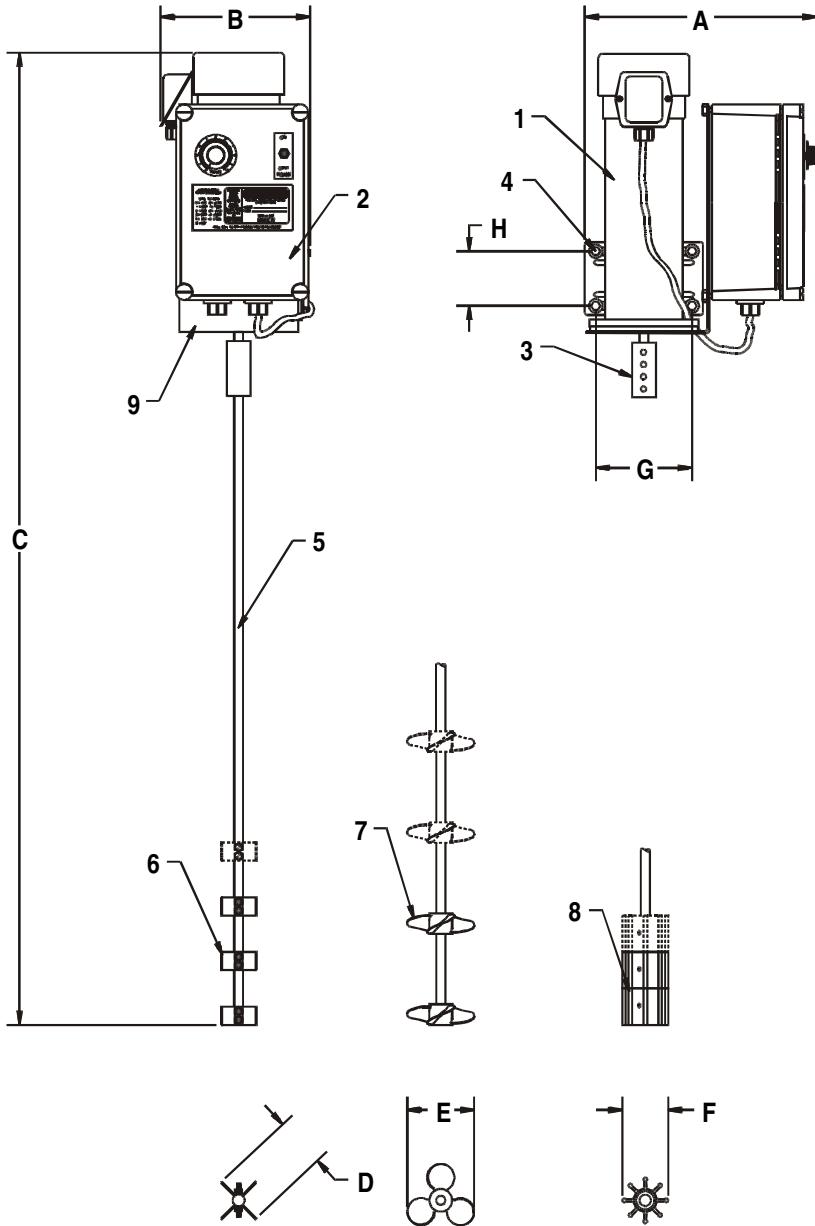

SPECIFICATIONS:

KEY	PART	DESCRIPTION
1	0432-A	MOTOR: 1/2 HP, TEFC, 100 to 1725 RPM
	0433-A	MOTOR: 1HP, TEFC, 100 to 1725 RPM
2	0440-A	SPEED CONTROLLER: 17:1, 115V speed controller
3	0253	COUPLING: 1/2" x 1/2" bored brass coupling with stainless set screws
	0254	COUPLING: 1/2" x 5/8" bored brass coupling with stainless set screws
4	0349	MOUNT: Plated steel mounting hardware
5	0315	SHAFT: 1/2" D x 36" L, 304 stainless steel shaft, prepped for 2 sets of impellers / propellers
	0316/44	SHAFT: 5/8" D x 44" L, 304 stainless steel shaft, prepped for 1 set of impellers / propellers
6	0265	[H] SS IMPELLER: 304 stainless steel 2 hole impellers with mounting hardware
7	0269	[PRP] PROPELLER: 316 stainless steel marine style 1/2" bore propeller with stainless steel set screw
	0270	[PRP] PROPELLER: 316 stainless steel marine style 5/8" bore propeller with stainless steel set screw
8	0264	[A] NEOPRENE IMPELLER: Large neoprene impeller, 1/2" bore with brass/copper hub
	0264-1	[A] NEOPRENE IMPELLER: Large neoprene impeller, 5/8" bore with brass/copper hub
9	0604	MOTOR BRACKET: 12GA controller to motor mounting ell bracket

NOTE: All replacement parts are based on standard mixer model number

DIMENSIONS, WEIGHT & CUBE:

KEY	VX-3-TE-[]	VX-4-TE-[]
A	10 1/2"	10 1/2"
B	8 1/2"	8 1/2"
C	48 3/4"	60 3/4"
D	2 3/8" diameter	2 3/8" diameter
E	4" diameter	4" diameter
F	2 1/2" diameter	2 1/2" diameter
G	5"	5"
H	3"	3"
Weight	30 lbs. approx.	43 lbs. approx.
Cube	10 3/8" X 12 3/8" X 36"	10 3/8" X 12 3/8" X 44"

MOTOR DATA:	VX-3-TE-[]	VX-4-TE-[]
Voltage	90 VDC	90 VDC
Full Load Amps	5.5	10.9
Service Factor	1.0	1.0
Insulation Class	F	F

Note: All dimensions are +/- 1/8". All weights are approximate. All dimensions are subject to change without notice.