

J.L. WINGERT CO.

P.O. Box 6207 • Garden Grove, CA 92846-6207 / 11800 Monarch Street • Garden Grove, CA 92841-2113
 Phone (714) 379-5519 • Fax (714) 379-5549 ■ Southwest Region • Phone (602) 470-1015
 30998 Huntwood Avenue, Unit 105 • Hayward, CA 94544-7033 • Phone (510) 487-5310 • Fax (510) 487-5137
 On the Internet: www.jlwingert.com • Email: customerservice@jlwingert.com

MANUFACTURING: Mixers, Bypass Feeders, Filter Feeders, Bromine Feeders, Sample Coolers, Sludge Traps, Separators, Separator Systems, Tank Stands,
 Tank Package Systems, Glycol Feed Systems, Coupon Racks, Control Stations, NEMA Enclosures, Custom Packaged Systems and Specialty Welding

Specification Sheet #012050 Rev. "E" (6/00)

MODEL B-1-EXP-[H/PRP/A] / B-2-EXP-[H/PRP/A]

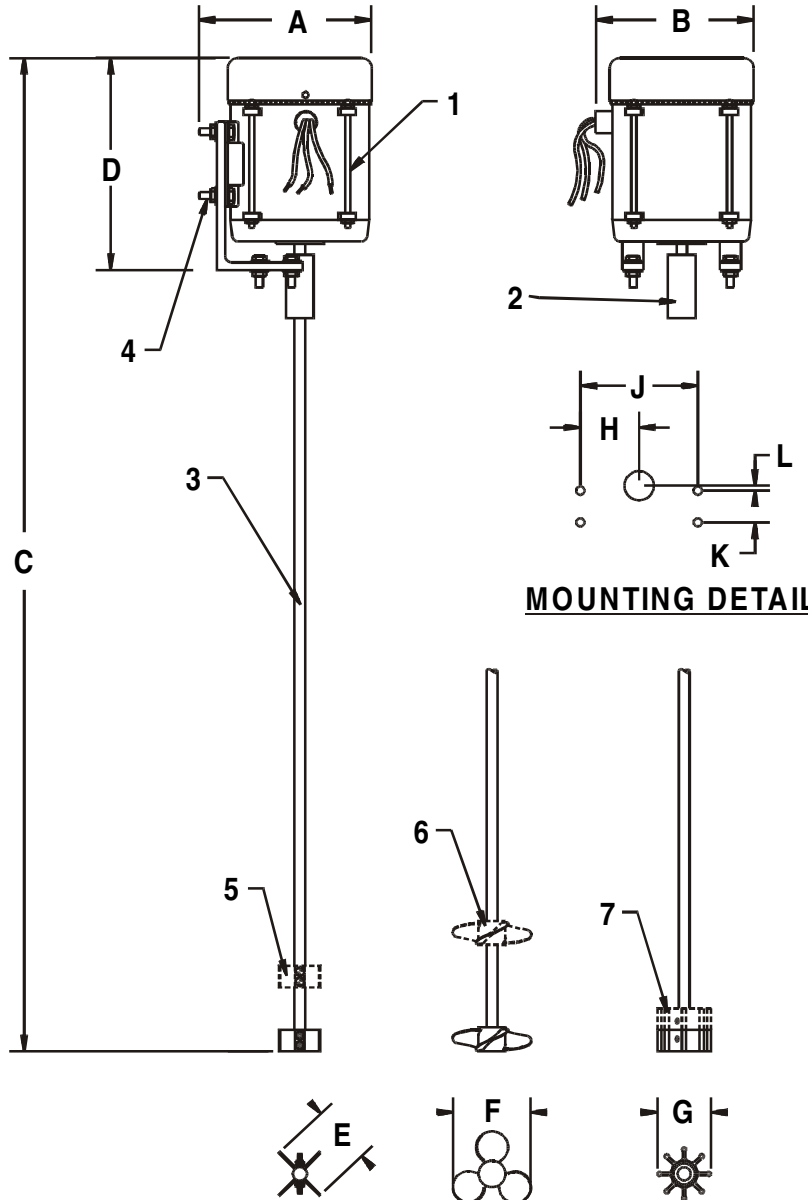

SPECIFICATIONS:

KEY	PART	DESCRIPTION
1	0401-I	MOTOR: 1/4 HP, 115V, 60Hz, 4.5FLA, explosion proof (B-1-EXP)
	0402-I	MOTOR: 1/3 HP, 115V, 60Hz, 6.4FLA, explosion proof (B-2-EXP)
2	0254	COUPLING: 1/2" x 5/8" bored brass coupling with stainless set screws
3	0315/34	SHAFT: 1/2" D x 34" L, 304 stainless steel shaft, prepped for 1 set of impellers / propellers (B-1-EXP)
	0315	SHAFT: 1/2" D x 36" L, 304 stainless steel shaft, prepped for 1 set of impellers / propellers (B-2-EXP)
4	0243	MOUNT: 3/8" thick steel mounting brackets with plated steel hardware
5	0265	[H] SS IMPELLER: 304 stainless steel 2 hole impellers with mounting hardware (316SS optional)
6	0269	[PRP] PROPELLER: 316 stainless steel marine style 1/2" bore propeller
7	0263	[A] NEOPRENE IMPELLER: Medium neoprene impeller, 1/2" bore with brass/copper hub (B-1-EXP)
	0264	[A] NEOPRENE IMPELLER: Large neoprene impeller, 1/2" bore with brass/copper hub (B-2-EXP)

NOTE: All replacement parts are based on standard mixer model number

DIMENSIONS, WEIGHT & CUBE:

KEY	B-1-EXP-[]	B-2-EXP-[]
A	7 1/8"	7 1/8"
B	7 1/4"	7 1/4"
C	48 1/4"	52 3/4"
D	11 1/4"	12 3/4"
E	2 3/8" diameter	2 3/8" diameter
F	4" diameter	4" diameter
G	2 1/2" diameter	2 1/2" diameter
H	2 5/8"	2 5/8"
J	5 3/8"	5 3/8"
K	1 1/2"	1 1/2"
L	1/2"	1/2"
Weight	30 lbs. approx.	30 lbs. approx.
Cube	10 3/8" X 12 3/8" X 36"	

MOTOR DATA:	B-1-EXP-[]	B-2-EXP-[]
Voltage	115	115
Phase / Hertz	1/60	1/60
Full Load Amps	4.5	6.4
Service Factor	1.0	1.0
Insulation Class	B	B

Note: All dimensions are +/- 1/8". All weights are approximate. All dimensions are subject to change without notice.