

# J.L. WINGERT CO.

P.O. Box 6207 • Garden Grove, CA 92846-6207 / 11800 Monarch Street • Garden Grove, CA 92841-2113  
 Phone (714) 379-5519 • Fax (714) 379-5549 ■ Southwest Region • Phone (602) 470-1015  
 30998 Huntwood Avenue, Unit 105 • Hayward, CA 94544-7033 • Phone (510) 487-5310 • Fax (510) 487-5137  
 On the Internet: [www.jlwingert.com](http://www.jlwingert.com) • Email: [customerservice@jlwingert.com](mailto:customerservice@jlwingert.com)

MANUFACTURING: Mixers, Bypass Feeders, Filter Feeders, Bromine Feeders, Sample Coolers, Sludge Traps, Separators, Separator Systems, Tank Stands,  
 Tank Package Systems, Glycol Feed Systems, Coupon Racks, Control Stations, NEMA Enclosures, Custom Packaged Systems and Specialty Welding

Specification Sheet #012033 Rev. "D" (6/00)

## MODEL F-2-O-[H/PRP/A]

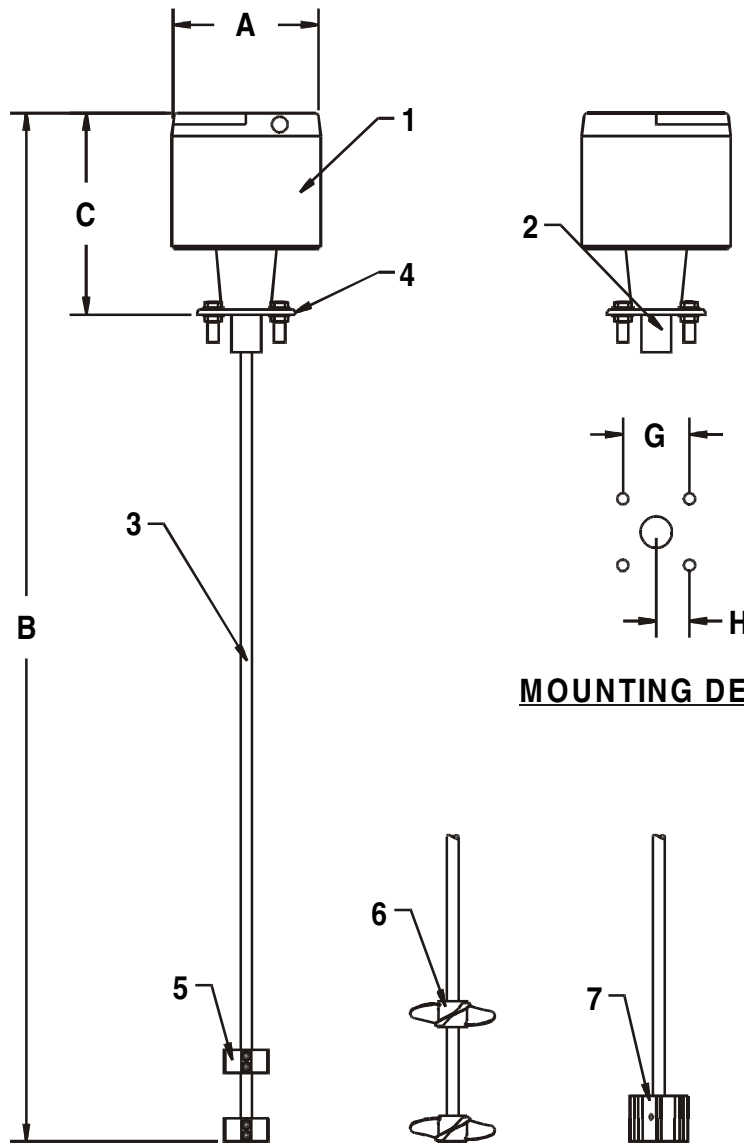

### SPECIFICATIONS:

KEY	PART	DESCRIPTION
1	0407-A	MOTOR: 1/3 HP, OPEN
2	0253	COUPLING: 1/2" x 1/2" bored brass coupling with stainless set screws
3	0315	SHAFT: 1/2" D x 36" L, 304 stainless steel shaft, prepped for # of sets of impellers / propellers
4	0247	MOUNT: Carbon steel mounting flange with plated steel hardware
5	0265	[H] SS IMPELLER: 304 stainless steel 2 hole impellers with mounting hardware
6	0269	[PRP] PROPELLER: 4" D, 316 stainless steel marine style 1/2" bore propeller with stainless steel set screw
7	0264	[A] NEOPRENE IMPELLER: Large neoprene impeller, 1/2" bore with brass/copper hub

NOTE: All replacement parts are based on standard mixer model number

### DIMENSIONS, WEIGHT & CUBE:

KEY	F-2-O- [ ]
A	6 1/4"
B	46"
C	10 1/4"
D	2 3/8" diameter
E	4" diameter
F	2 1/2" diameter
G	2"
H	1"
Weight	28 lbs. approx.
Cube	10 3/8" X 12 3/8" X 36"

MOTOR DATA:	F-2-O- [ ]
Voltage	115
Phase / Hertz	1 / 60
Full Load Amps	5.4
Service Factor	1.15
Insulation Class	A

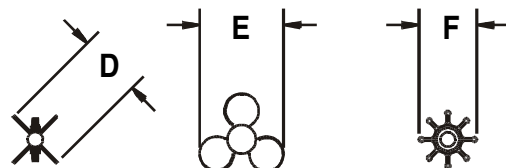

Note: All dimensions are +/- 1/8". All weights are approximate. All dimensions are subject to change without notice.