

J.L. WINGERT CO.

P.O. Box 6207 • Garden Grove, CA 92846-6207 / 11800 Monarch Street • Garden Grove, CA 92841-2113
 Phone (714) 379-5519 • Fax (714) 379-5549 ■ Southwest Regional Sales Office Phone (602) 470-1015
 30998 Huntwood Avenue, Unit 105 • Hayward, CA 94544-7033 • Phone (510) 487-5310 • Fax (510) 487-5137

On the Internet: www.jlwingert.com • Email: customerservice@jlwingert.com

MANUFACTURING: Mixers, Bypass Feeders, Filter Feeders, Sample Coolers, Sludge Traps, Separators, Tank Stands,
 Tank Package Systems, Glycol Feed Systems, Coupon Racks, Custom Packaged Systems and Specialty Welding

Specification Sheet #012031 Rev. "C" (11/99)

MODEL C-1-O-[H/PRP/A] / C-2-O-[H/PRP/A]

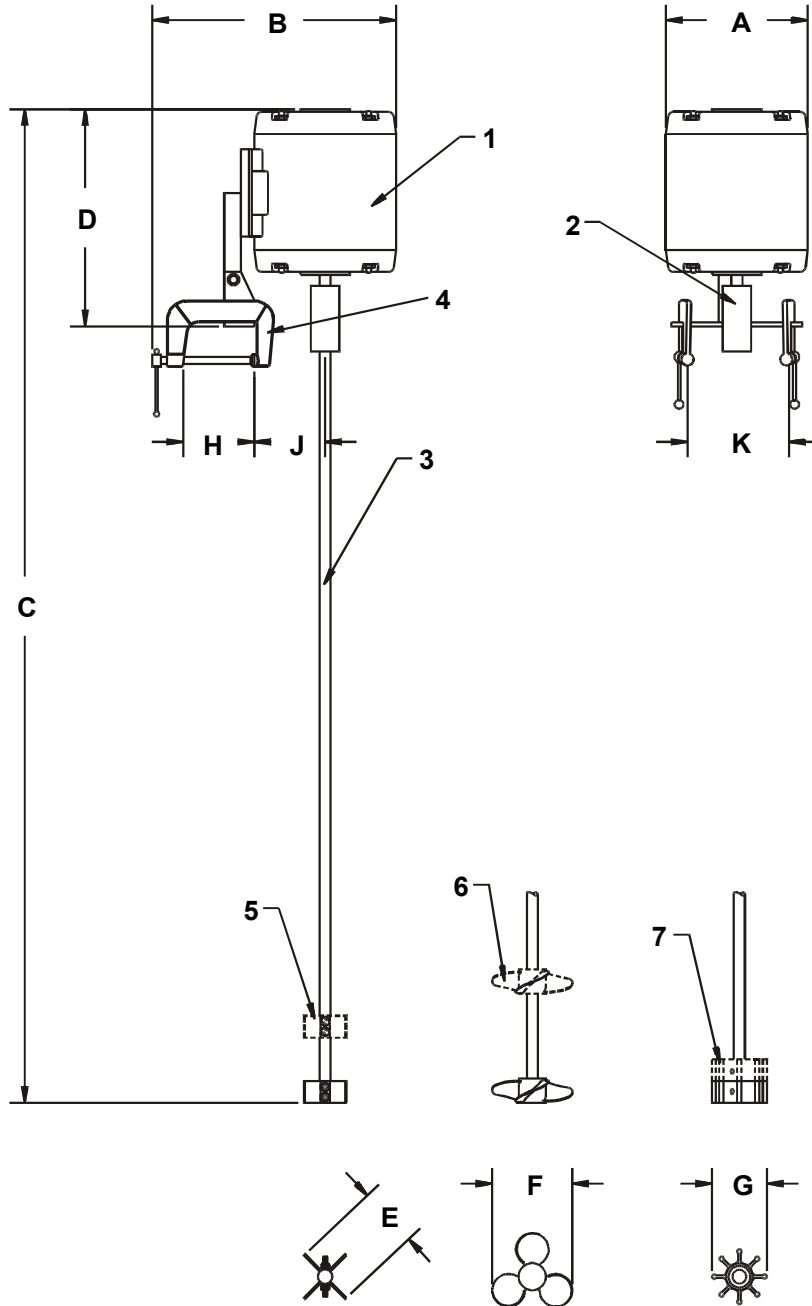

SPECIFICATIONS:

KEY	PART	DESCRIPTION
1	0401-A	MOTOR: 1/4 HP, OPEN
	0402-A	MOTOR: 1/3 HP, OPEN
2	0253	COUPLING: 1/2" x 1/2" bored brass coupling with stainless set screws
3	0315/34	SHAFT: 1/2" D x 34" L, 304 stainless steel shaft, prepped for 1 set of impellers / propellers
	0315	SHAFT: 1/2" D x 36" L, 304 stainless steel shaft, prepped for 2 sets of impellers / propellers
4	0239	MOUNT: 3" double c-clamps welded to a 3 position angle plate
5	0265	[H] SS IMPELLER: 304 stainless steel 2 hole impellers with mounting hardware
6	0269	[PRP] PROPELLER: 4" D, 316 stainless steel marine style 1/2" bore propeller
7	0263	[A] NEOPRENE IMPELLER: Medium neoprene impeller, 1/2" bore with brass/copper hub

NOTE: All replacement parts are based on standard mixer model number

DIMENSIONS, WEIGHT & CUBE:

KEY	C-1-O-[]	C-2-O-[]
A	6 1/4"	6 1/4"
B	10"	10"
C	44 1/4"	46 1/4"
D	10 1/2"	10 1/2"
E	2 3/8" diameter	2 3/8" diameter
F	4" diameter	4" diameter
G	2 1/2" diameter	2 1/2" diameter
H	3"	3"
J	3 1/4"	3 1/4"
K	4 1/2"	4 1/2"
Weight	33 lbs. approx.	33 lbs. approx.
Cube	10 3/8" X 12 3/8" X 36"	

MOTOR DATA:	C-1-O-[]	C-2-O-[]
Voltage	115	115
Phase / Hertz	1 / 60	1 / 60
Full Load Amps	5.4	6.0
Service Factor	1.15	1.15
Insulation Class	A	A

Note: All dimensions are +/- 1/8". All weights are approximate. All dimensions are subject to change without notice.