

# J.L. WINGERT CO.

P.O. Box 6207 • Garden Grove, CA 92846-6207 / 11800 Monarch Street • Garden Grove, CA 92841-2113  
 Phone (714) 379-5519 • Fax (714) 379-5549 ■ Southwest Region • Phone (602) 470-1015  
 30998 Huntwood Avenue, Unit 105 • Hayward, CA 94544-7033 • Phone (510) 487-5310 • Fax (510) 487-5137  
 On the Internet: [www.jlwingert.com](http://www.jlwingert.com) • Email: [customerservice@jlwingert.com](mailto:customerservice@jlwingert.com)

MANUFACTURING: Mixers, Bypass Feeders, Filter Feeders, Sample Coolers, Sludge Traps, Separators, Tank Stands,  
 Tank Package Systems, Glycol Feed Systems, Coupon Racks, Custom Packaged Systems and Specialty Welding

Specification Sheet #012001 Rev. "D" (4/00)

## MODEL B-M-TE-[H/PRP/A]

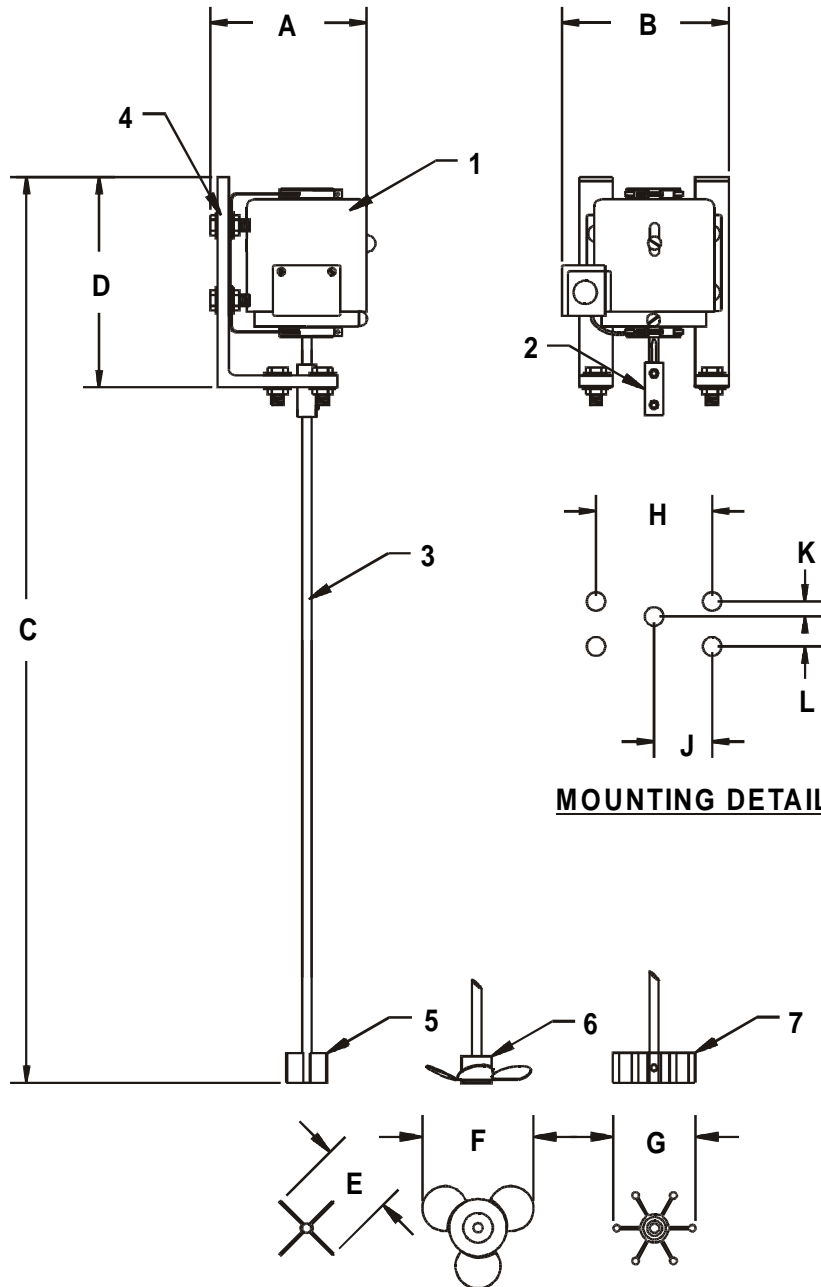

### SPECIFICATIONS:

KEY	PART	DESCRIPTION
1	0400-E	MOTOR: 1/20 HP, TEFC
2	0252	COUPLING: 5/16" x 5/16" bored brass coupling with stainless set screws
3	0314/28	SHAFT: 5/16" D x 28" L, 304 stainless steel shaft. (for neoprene impeller and SS propeller)
4	0241	MOUNT: 3/8" thick steel mounting brackets, hardware is plated steel
5	0279/28"	[H] SS IMPELLER: 304 stainless steel fabricated to shaft
6	0268	[PRP] PROPELLER: 316 stainless steel propeller with stainless steel set screws
7	0262	[A] NEOPRENE IMPELLER: small neoprene impellers with brass/copper hub

\* NOTE: Shaft and [H] style stainless steel impellers are prefabricated at the factory (not sold individually)

### DIMENSIONS, WEIGHT & CUBE:

KEY	B-M-TE-[ ]
A	5"
B	5 1/2"
C	34 7/8"
D	7"
E	1 3/4"
F	4" diameter
G	1 3/4"
H	3 1/2"
J	1 3/4"
K	1/2"
L	1 1/2"
Weight	9 lbs. approx.
Cube	10" X 12" X 36"

MOTOR DATA:	B-M-TE-[ ]
Voltage	115
Phase / Hertz	1 / 60
Full Load Amps	1.5
Service Factor	1.0
Insulation Class	A

Note: All dimensions are +/- 1/8". All weights are approximate. All dimensions are subject to change without notice.