



3-8350.090-3



C-3/01 English



CAUTION!

- Remove power to unit before wiring input and output connections.
- Follow instructions carefully to avoid personal injury.

Contents

1. Installation
2. Specifications
3. Electrical Connections
4. Menu Functions



1. Installation

ProcessPro transmitters are available in two styles: panel mount and field mount. The panel mount is supplied with the necessary hardware to install the transmitter. This manual includes complete panel mounting instructions.

Field mounting requires one of two separate mounting kits. The 3-8052 integral kit joins the sensor and instrument together into a single package. The 3-8050 Universal kit enables the transmitter to be installed virtually anywhere.

Detailed instructions for integral mounting or other field installation options are included with the 3-8052 Integral kit or the 3-8050 Universal kit.

1.1 Panel Installation

1. The panel mount transmitter is designed for installation using a 1/4 DIN Punch. For manual panel cutout, an adhesive template is provided as an installation guide. Recommended clearance on all sides between instruments is 1 inch.
2. Place gasket on instrument, and install in panel.
3. Slide mounting bracket over back of instrument until quick-clips snap into latches on side of instrument.
4. To remove, secure instrument temporarily with tape from front or grip from rear of instrument. **DO NOT RELEASE.** Press quick-clips outward and remove.

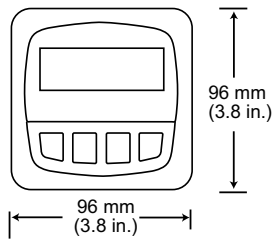

FRONT VIEW
Field Mount &
Panel Mount

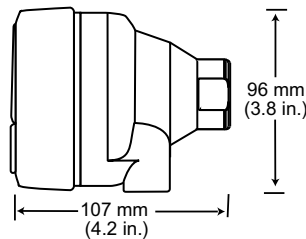

SIDE VIEW
Field Mount

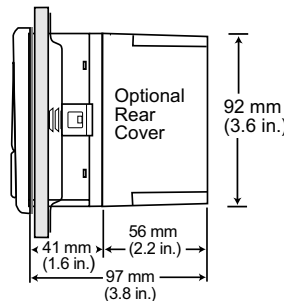

SIDE VIEW
Panel Mount

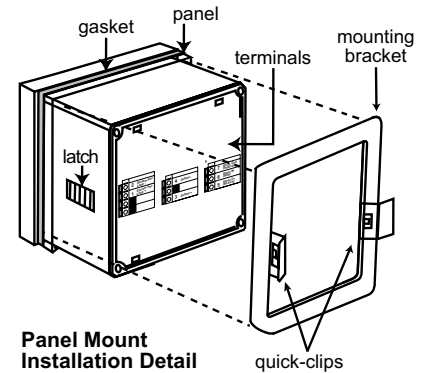

Panel Mount
Installation Detail

2. Specifications

General

Compatibility: +GF+ SIGNET 3-2350-1 or -2 Temperature Sensors

Accuracy: $\pm 0.5^\circ\text{C}$

Enclosure:

- Rating: NEMA 4X/IP65 front
- Case: PBT
- Panel case gasket: Neoprene
- Window: Polyurethane coated polycarbonate
- Keypad: Sealed 4-key silicone rubber
- Weight: Approx. 325g (12 oz.)

Display:

- Alphanumeric 2 x 16 LCD
- Update rate: 1 second
- Contrast: User selected, 5 levels

Electrical

- Power: 12 to 24 VDC $\pm 10\%$ regulated, 21 mA max current
- Current output:
4 to 20 mA, isolated, fully adjustable and reversible
- Max loop impedance:
50 Ω max. @ 12 V, 325 Ω max. @ 18 V, 600 Ω max. @ 24 V
- Update rate: 100 ms
- Output accuracy: ± 0.03 mA

Open-collector output:

- Optically isolated, 50 mA max. sink
- 30 VDC maximum pull-up voltage.
- Programmable for:
 - Hi, Lo with adjustable hysteresis
 - Pulse operation (maximum pulse rate: 400 pulses/min).

Environmental

- Operating temperature: -10 to 70°C (14 to 158°F)
- Storage temperature: -15 to 80°C (5 to 176°F)
- Relative humidity: 0 to 95%, non-condensing
- Maximum altitude: 2000 m (6562 ft)
- Insulation category: II
- Pollution degree: 2

Standards and Approvals:

- CSA, CE, UL listed
- Immunity: EN50082-2
- Emissions: EN55011
- Safety: EN61010
- Manufactured under ISO 9001 and ISO 14001

3. Electrical Connections



Caution: Failure to fully open terminal jaws before removing wire may permanently damage instrument.

Wiring Procedure

1. Remove 0.5 - 0.625 in. (13-16 mm) of insulation from wire end.
2. Press the orange terminal lever downward with a small screwdriver to open terminal jaws.
3. Insert exposed (non-insulated) wire end in terminal hole until it bottoms out.
4. Release orange terminal lever to secure wire in place. Gently pull on each wire to ensure a good connection.

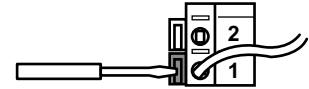

Wiring Removal Procedure

1. Press the orange terminal lever downward with a small screwdriver to open terminal jaws.
2. When fully open, remove wire from terminal.

Terminals 3-4: Primary Loop Power
 12-24 VDC $\pm 10\%$ system power and current loop connections.
 SINGLE SENSOR system MUST use terminals 3-4.

Terminals 5-6: 12-24 VDC $\pm 10\%$
 Power and current loop connections for second sensor.
 Max. loop impedance:
 50 Ω max. @ 12 V
 325 Ω max. @ 18 V
 600 Ω max. @ 24 V

Terminals 11-16: Dual digital sensor inputs
 See next page for more information.

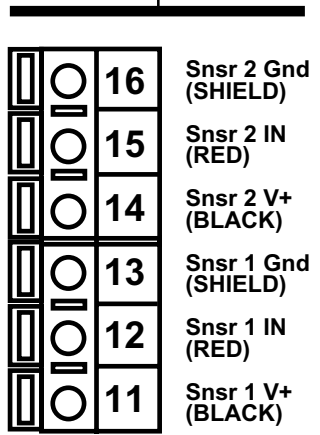
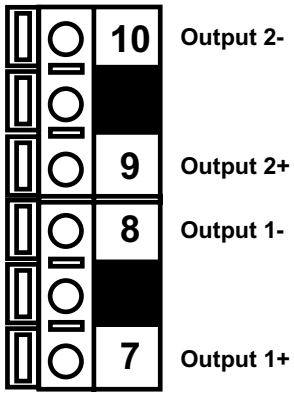
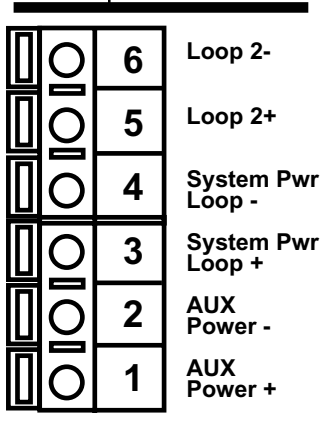

Terminals 1-2: Auxiliary power is used only if two sensors are connected to the transmitter.

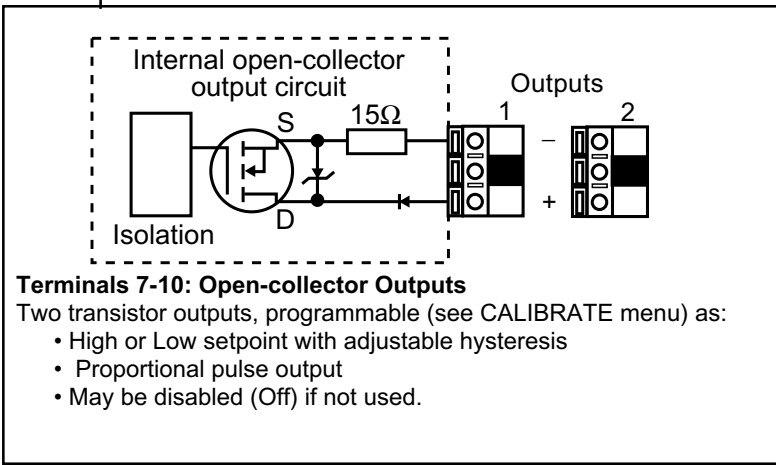

3.1 System Power/Loop Connections

Stand-alone application, no current loop used

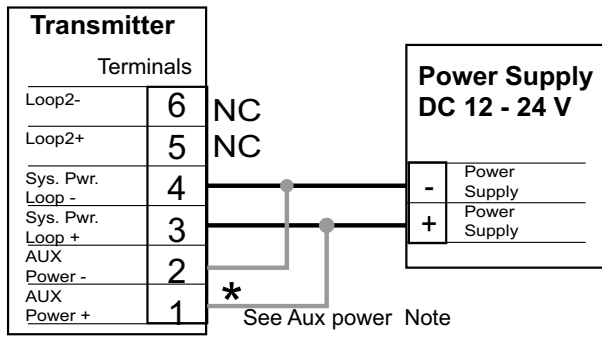

Connection to a PLC with built-in power supply

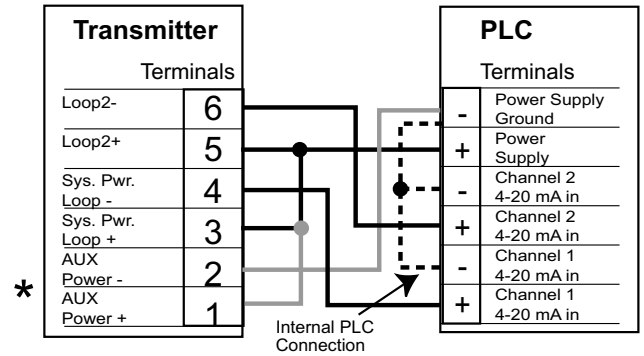

Connection to a PLC/Recorder, separate supply

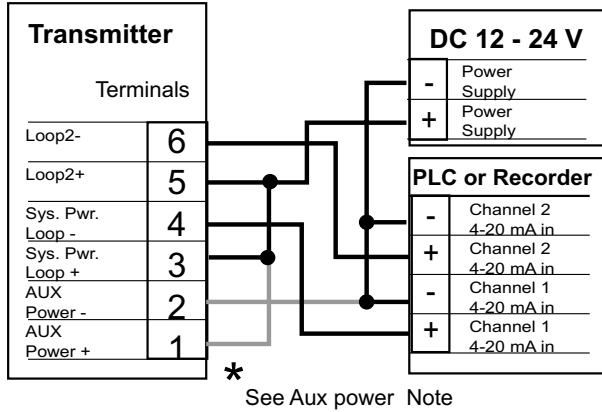

Example: Two transmitters connected to PLC/Recorder with separate power supply

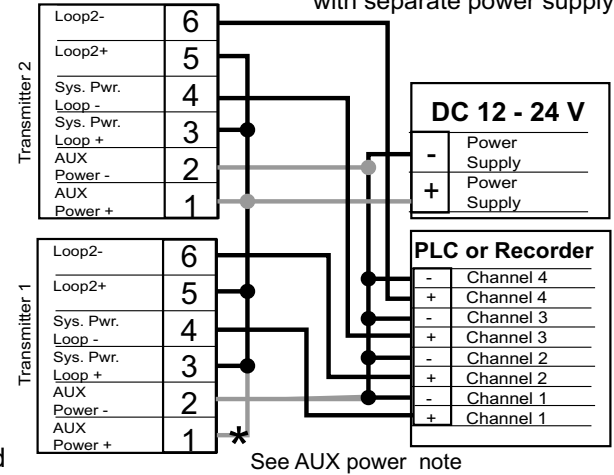

* Note: AUX power required only where two sensors are used

3.2 Sensor Input Connections

Wiring Tips:

- Do not route sensor cable in conduit containing AC power wiring. Electrical noise may interfere with sensor signal.
- Routing sensor cable in grounded metal conduit will help prevent electrical noise and mechanical damage.
- Seal cable entry points to prevent moisture damage.
- Only one wire should be inserted into a terminal. Splice double wires outside the terminal.
- If your system uses a single sensor, it must be located within 400 ft. (122 m) of the transmitter.
- If your system uses two sensors, the total length of cable connected to the transmitter is limited to 400 ft.
- The 3 conductors from a dual-sensor system can be tied together and then a single set of wires continued on to the transmitter.
- For best performance, ground the sensor SHIELD wire to a local earth ground at a point near the sensor. (Experiment by connecting the sensor shield wire to different local ground points to identify best signal quality.)

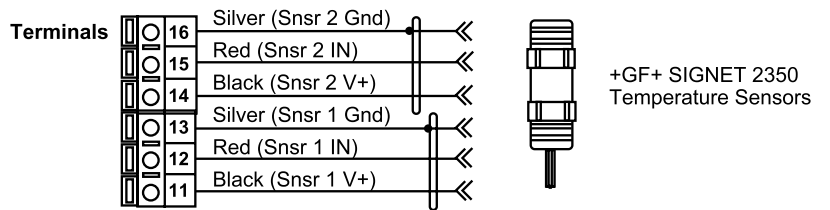
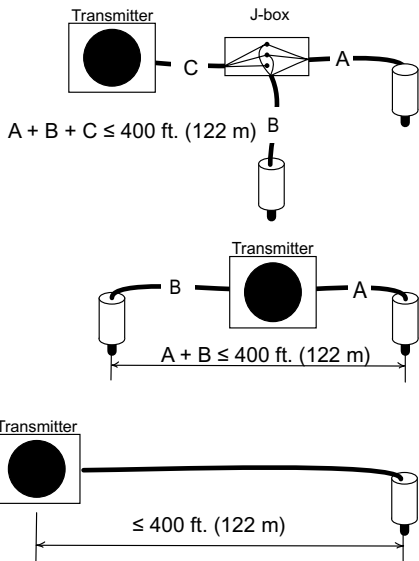

3.3 Open Collector Output

The Open Collector output can be used as a switch that responds when the process value moves above or below a setpoint, or it can be used to generate a pulsing signal with a rate proportional to the process value.

- **Low:**

Output triggers when process variable is less than the setpoint. The output will relax when the process variable moves above the setpoint plus the hysteresis value.

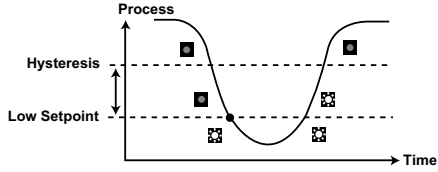

- **High:**

Output triggers when process variable is greater than the setpoint. The output will relax when the process variable moves below the setpoint plus the hysteresis value.

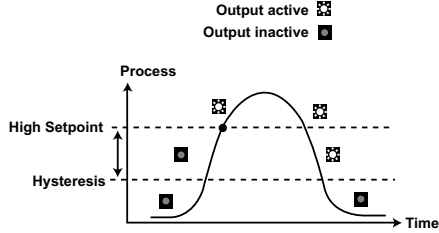

Delta Temperature (Differential Mode)

If two sensors are connected to the transmitter, the DELTA (Sensor 1 - Sensor 2) can be assigned to output. To enable differential mode, the selected output "Source" selection must be set to "DT".

Sensor 1 must be equal to ID 1. If it is not, go to the Calibrate menu and switch the sensor id.

In the example below, Sensor 1 is measuring 80° while sensor 2 is measuring 20°. The delta is 60° (Sensor 1 - Sensor 2 = 60°)

To track the delta temperature using a 4-20 mA output:

Loop1 Source: DT
 Loop1 Range: 0-100
 Loop1 = 13.60 mA

To set a delta temperature setpoint using a Open Collector output:
 Output1 Source: DT
 Output1 Mode: Low
 Output1 Setpoint: 70
 Output1 = ON

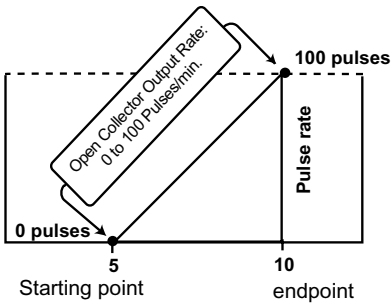
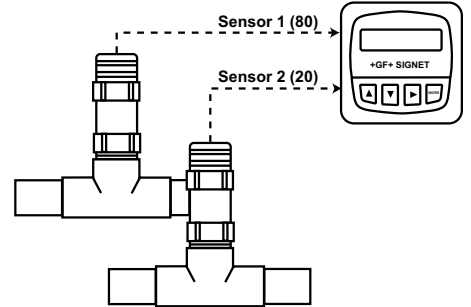

- **Proportional Pulsing**

The Open Collector output will generate a 100 mS pulse at the rate defined by settings in the CALIBRATE menu (see page 6)

In the example:

- The output will be 0 pulses/min. at temperatures less than 5°.
- The output will be 50 pulses/min. at 7.5°.
- The output will be 100 pulses/min. at temperatures above 10°.

The starting point, endpoint and maximum pulse rate are selectable in the menu.

VIEW menu

- During normal operation, ProcessPro displays the VIEW menu.
- When editing CALIBRATE or OPTIONS menus, ProcessPro returns to the VIEW menu if no activity occurs for 10 minutes.
- To select a VIEW display, press the UP or DOWN arrow keys. The selections will scroll in a continuous loop.
- Changing the display selection does not interrupt system operations.
- No key code is necessary to change display selection.
- Output settings cannot be edited from the VIEW menu.



View Menu

Display	Description
Temp1: 25 °C Temp2: 18 °C	Monitor Temperature 1 and Temperature 2 simultaneously. This is the permanent display.

The displays below are temporary. The permanent display will return after 10 minutes

Delta Temperature: 7 °C	Monitor the difference between Temperature 1 and Temperature 2 (Temp1 - Temp2)
Loop 1 Output: 12.00 mA	Monitor Loop 1 and Loop 2 mA outputs.
Loop 2 Output: 7.65 mA	
Last Cal 06-30-01	Monitor date for scheduled maintenance or date of last calibration.

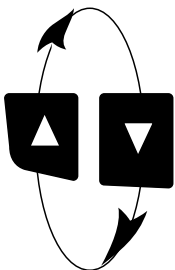

ProcessPro Editing Procedure:

Step 1. Press and hold ENTER key:

- 2 seconds to select the CALIBRATE menu
- 5 seconds to select the OPTIONS menu.

Step 2. The Key Code is UP-UP-UP-DOWN keys in sequence.

- After entering the Key Code, the display will show the first item in the selected menu.

Step 3. Scroll menu with UP or DOWN arrow keys.

Step 4. Press RIGHT ARROW key to select menu item to be edited.

- The first display element will begin flashing.

Step 5. Press UP or DOWN keys to edit the flashing element.

- RIGHT ARROW key advances the flashing element.

Step 6. Press ENTER key to save the new setting and return to Step 3.

Notes on Step 1:

- The View Menu is normally displayed.
- The CALIBRATE and OPTIONS menus require a KEY CODE.

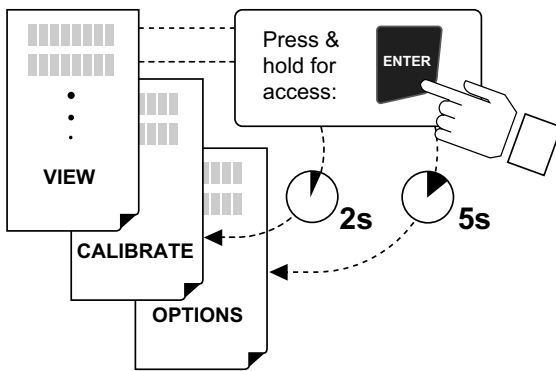

Notes on Step 2:

If no key is pressed for 5 minutes while display is showing "Enter Key Code", the display will return to the VIEW menu.

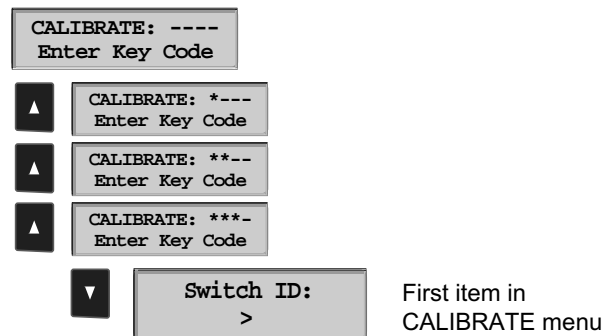

Notes on Steps 3 and 4:

- Refer to pages 6 and 7 for complete listing of menu items and their use.
- From the Step 3 display, pressing the UP and DOWN keys simultaneously will return the display to the VIEW menu.
- If no key is pressed for 10 minutes, display will also return to the VIEW menu.



Step 3: Finished Editing?

Press the UP and DOWN keys simultaneously after saving the last setting to return to normal operation.

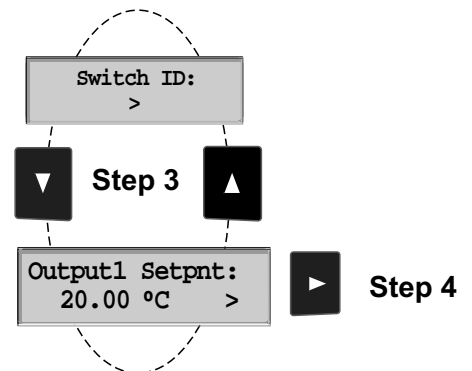

Notes on Steps 5 and 6:

- All output functions remain active during editing.
- Only the flashing element can be edited.
- RIGHT ARROW key advances the flashing element in a continuous loop.
- Edited value is effective immediately after pressing ENTER key.
- If no key is pressed for 10 minutes unit will restore the last saved value and return to step 3.
- Step 6 (pressing ENTER key) always returns you to Step 3.
- Repeat steps 3-6 until all editing is completed.

Step 5: Made an Error?

Press the UP and DOWN keys simultaneously while any element is flashing. This will recall the last saved value of the item being edited and return you to Step 3.



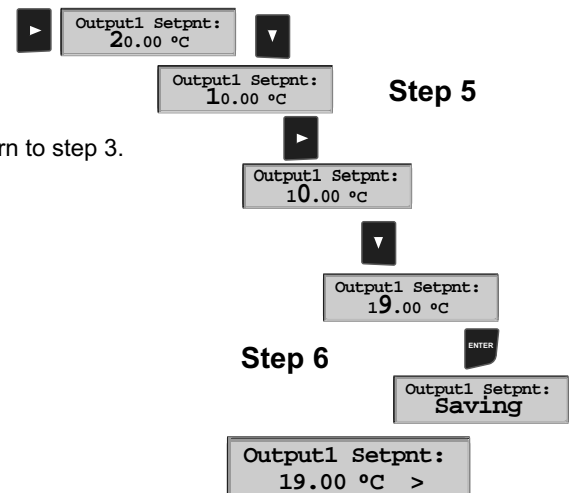

Options Menu

Display (Factory settings shown)	Description
Contrast: 3 >	Adjust the LCD contrast for best viewing. A setting of 1 is lower contrast, 5 is higher. In general, select lower contrast if the display is in warmer ambient surroundings.
Averaging Off >	OFF provides the most instantaneous response to changes in temperature. It is the preferred option in systems where the measurement is very stable. Select LOW (4 s) or HIGH (8 s) averaging if your process experiences frequent or extreme fluctuations in temperature.
Output1 Active Low >	Active HIGH: This setting is used to turn a device (pump, valve) ON at the setpoint. Active LOW: This setting is used to turn a device OFF at the setpoint.
Output2 Active Low >	
Loop 1 Adjust: 4.00 mA >	Adjust the minimum and maximum current output. The display value represents the precise current output. Adjustment limits: <ul style="list-style-type: none"> • 3.80 mA < 4.00 mA > 5.00 mA • 19.00 mA < 20.00 mA > 21.00 mA Use this setting to match the system output to any external device.
Loop 1 Adjust: 20.00 mA >	
Test Loop 1: >	Press UP and DOWN keys to manually order any output current value from 3.6 mA to 21.00 mA to test the output loop.
Test Loop 2: >	
Test Output 1 >	Press UP and DOWN keys to manually toggle the Open Collector output state.
Test Output 2 >	

Settings will repeat for Loop 2 and Output 2.

Troubleshooting

Display Condition	Possible Causes	Suggested Solutions
"Check Sensor?"	<ul style="list-style-type: none"> • Sensor not wired properly. • Sensor was not connected to 8350 at power-up. • Defective sensor. 	<ul style="list-style-type: none"> • Correct sensor wiring. • Recycle power with all sensors connected. • Replace defective sensor.
"Too much error CHECK SENSOR"	The value entered in Set Temperature field is greater than 20° deviation from sensor input. (The 8350 allows a maximum of 20° calibration offset.)	<ul style="list-style-type: none"> • Confirm calibration values. • Enter -999 in Set Temperature field. • Replace 2350 sensor.
"Reset to Factory Calibration"	Value in Set Temperature field is -999.	Entering "-999" in this field will remove all user calibration input and restore the factory values.
Open Collector output is always activated	Hysteresis value too large.	Reset hysteresis value in Calibrate menu.
"SETUP READ ERROR Press Any Key"	Memory fault occurred.	<ul style="list-style-type: none"> • Press any key to reload factory presets. • Reprogram all setpoints. • If this message appears again, replace the 8350.

+GF+ SIGNET

Signet Scientific Company, 3401 Aerojet Avenue, El Monte, CA 91731-2882 U.S.A. • Tel. (626) 571-2770 • Fax (626) 573-2057
For Worldwide Sales and Service, visit our website: www.gfsignet.com • Or call (in the U.S.): (800) 854-4090

