

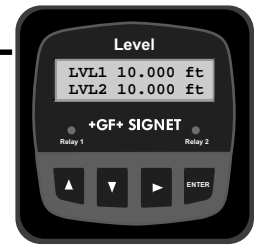

3-8250.090-3



A-8/01 English



CAUTION!



- Remove power to unit before wiring input and output connections.
- Follow instructions carefully to avoid personal injury.

Contents

- | | |
|---------------------------|----------------------|
| 1. Description | 6. View menu |
| 2. Specifications | 7. Editing procedure |
| 3. Panel installation | 8. Calibrate menu |
| 4. Electrical connections | 9. Options menu |
| 5. System configuration | 10. Troubleshooting |

1. Description

- ProcessPro transmitters are available in two styles: panel mount and field mount. The panel mount is supplied with the necessary hardware to install the transmitter. This manual includes complete panel mounting instructions.
- Field mounting requires one of two separate mounting kits. The 3-8052 integral kit joins sensor and instrument together into a single package. The 3-8050 Universal kit enables the transmitter to be installed virtually anywhere.
- Detailed instructions for integral mounting or other field installation options are included with the 3-8052 Integral kit or the 3-8050 Universal kit.

2. Specifications

Dimensions

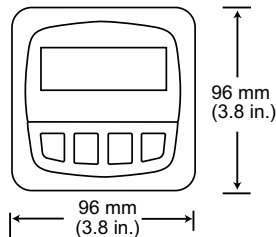

FRONT VIEW

Field & Panel Mount

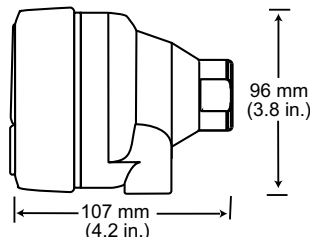

SIDE VIEW

Field Mount with 8052 Integral kit

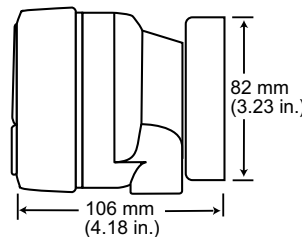

SIDE VIEW

Field Mount with 8050 Universal kit

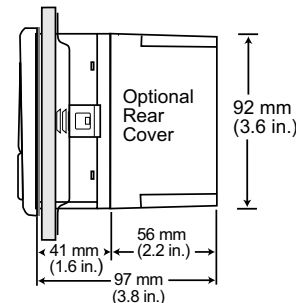

SIDE VIEW

Panel Mount with NEMA 4X rear cover

General

Compatible Sensors:

- +GF+ SIGNET level and pressure sensors with * S³L™ output

Enclosure: NEMA 4X/IP65 front

Materials:

- Case: PBT
- Panel case gasket: Neoprene
- Window: Polyurethane-coated polycarbonate
- Keypad: Silicone rubber

Weight: Approx. 325g (12 oz.)

Display:

- Alphanumeric 2 x 16 LCD
- Sealed 4-button keypad
- Display update rate: 1 second
- Contrast: User selected, 5 levels

Environmental

- Operating temperature: -10 to 70°C (14 to 158°F)
- Storage temperature: -15 to 80°C (5 to 176°F)
- Relative humidity: 0 to 95%, non-condensing
- Maximum altitude: 2000 m (6562 ft)

Electrical

Power supply: 12-24 VDC ±10% regulated, 250 mA max current

Sensor power (provided by 8250): 5 VDC ±1% @ 25°C, regulated

2-wire system: 1.5 mA maximum current

4-wire system: 20 mA maximum current

Current output (2 loops provided):

- 4 to 20 mA, isolated, fully adjustable and reversible
- Max loop impedance: 50Ω max. @ 12 V
325Ω max. @ 18 V
600Ω max. @ 24 V
- Update rate: 300 ms
- Output accuracy: ±0.03 mA

Relay outputs:

- * 2 sets mechanical SPDT contacts standard with all units.
- Software supports 2 additional relays via optional external relay module
- Maximum voltage rating: 5 A @ 30 VDC, or 5 A @ 250 VAC, resistive load
- Programmable for High or Low setpoint or for Window range, with adjustable hysteresis
- May be disabled if not used
- Time delay: programmable from 0 to 6400 s

Standards and Approvals:

- CSA, CE, UL listed
- Immunity: EN50082-2
- Emissions: EN55011
- Safety: EN61010
- Manufactured under ISO 9001 and ISO 14001

* S³L is **Signet Sensor Serial Link**

3. Panel Installation

1. The panel mount transmitter is designed for installation using a 1/4 DIN Punch. For manual panel cutout, an adhesive template is provided as an installation guide. The cutout must be 92 mm x 92 mm. Recommended clearance on all sides between instruments is 25 mm/1 in.
2. Slide the instrument into the cutout from the front of the panel.
3. Slide the mounting bracket over back of instrument until quick-clips snap into latches on side of instrument.
4. To remove, secure instrument temporarily with tape from front or grip from rear of instrument. **DO NOT RELEASE.** Press quick-clips outward and remove.

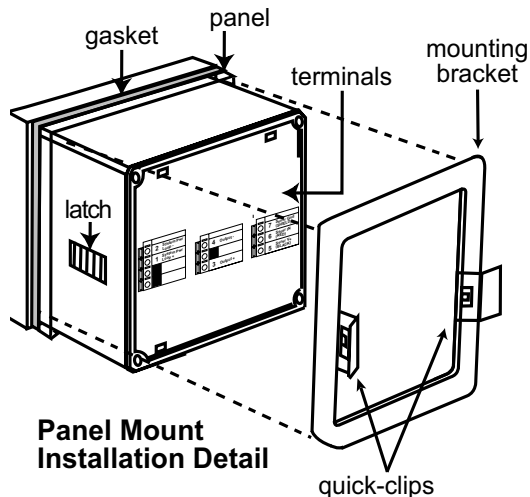

Panel Mount Installation Detail

4. Electrical Connections

Wiring Procedure

1. Remove 0.5 - 0.625 in. (13-16 mm) of insulation from wire end.
2. Press the orange terminal lever downward with a small screwdriver to open terminal jaws.
3. Insert wire into terminal until it bottoms out.
4. Release orange terminal lever to secure wire in place. Gently pull on each wire to ensure a good connection.

Wiring Removal Procedure

1. Press the orange terminal lever downward with a small screwdriver to open terminal jaws.
2. When fully open, remove wire from terminal.

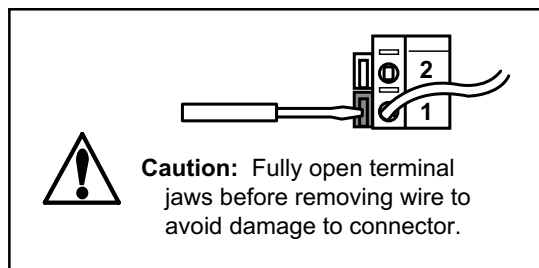

Terminals 3 and 4: Loop 1 Power and system power

Terminals 5-6: Loop 2 power

12-24 VDC $\pm 10\%$

Max. loop impedance: 50 Ω max. @ 12 V
 325 Ω max. @ 18 V
 600 Ω max. @ 24 V

Terminals 13-18: S³L™ input/output

Two sensors and one External Relay Module connect here.

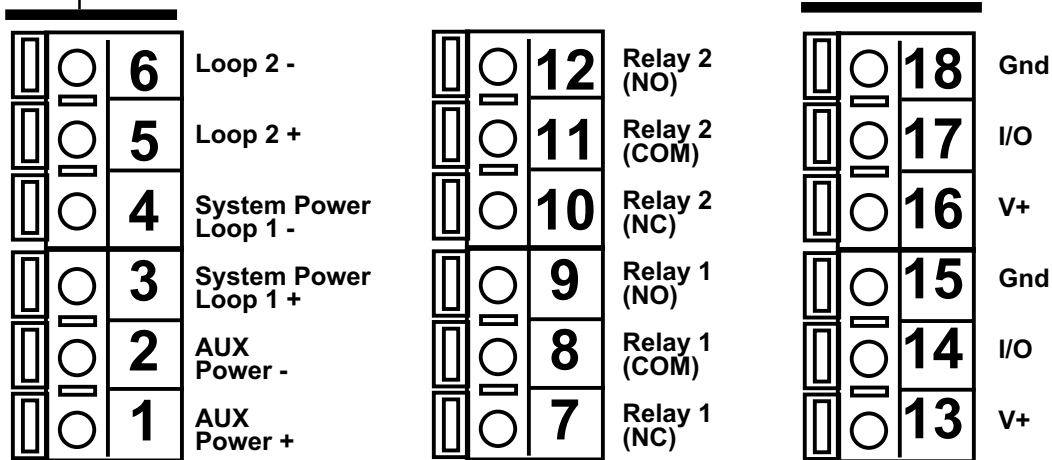

Terminals 1 and 2: AUXILIARY power

Required for all systems that include any one of the following features:

- Any relay operation
- 2222 Magnetostrictive sensor
- 2210 Ultrasonic sensor
- All dual sensor systems

Terminals 7-12: Relay Outputs

2 sets mechanical SPDT contacts programmable as:

- High or Low setpoint with adjustable hysteresis
- "Window" limits with adjustable hysteresis
- Time delay up to 6400 seconds.
- May be disabled (Off) if not used.
- Auxiliary power (terminals 1-2) **MUST** be connected for relay operation

4.1 System Power/Loop Connections

Stand-alone application, no current loop used

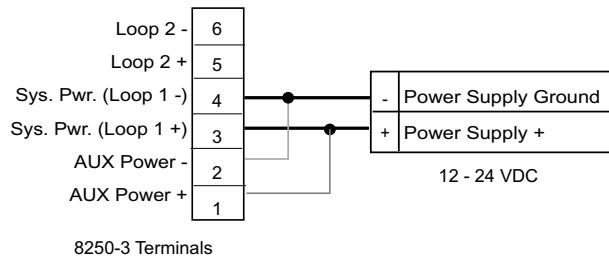

Connection to a PLC with built-in power supply

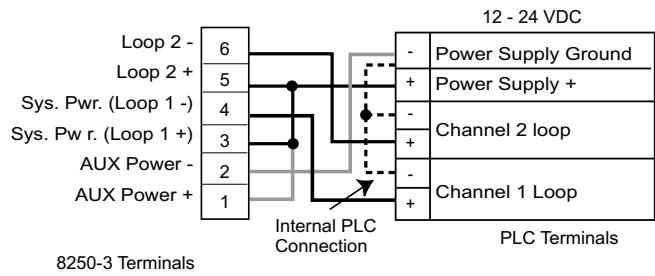

Connection to a PLC/Recorder, separate supply

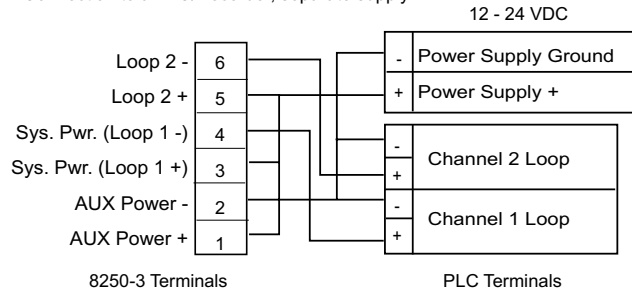

Two transmitters connected to PLC/Recorder with separate power supply

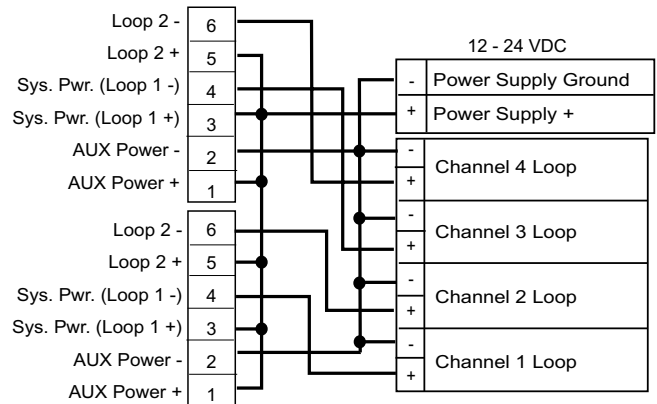

Note:

AUXILIARY power is required:

- for all dual-sensor systems
- to operate the relays.
- to provide power to the 2222 magnetostrictive level sensor
- to provide power to the 2210 ultrasonic level sensor.

4.2 Serial Data Connections

- The Input/Output terminals on the 8250 carry S³L™ serial data from two level sensors and from the external relay module.
- The two sets of serial input terminals are parallel. It does not matter which terminals are used, or the order of the sensors connected.
- You **MUST** reset sensor configuration (see Calibrate menu) for all new systems and after connecting any new sensor to the I/O terminals.
- Use the SWITCH SENSOR ID function (Calibrate menu) to reverse LEVEL 1 and LEVEL 2 if necessary.
- Do not route sensor or output cables in conduit containing AC power wiring. Electrical noise may interfere with sensor signal.
- Routing cable in grounded metal conduit will help prevent electrical noise and mechanical damage.
- Seal cable entry points to prevent moisture damage.
- Only one wire should be inserted into a terminal. Splice double wires outside the terminal.
- The **TOTAL** cable length from all I/O devices to the transmitter must not exceed 122 m (400 ft.).
- For best performance, ground the sensor SHIELD wire to a local earth ground at a point near the sensor.
- Consult the sensor manual for additional wiring information.

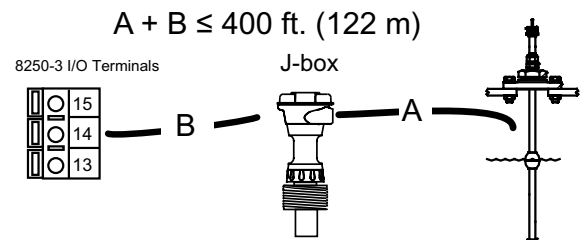
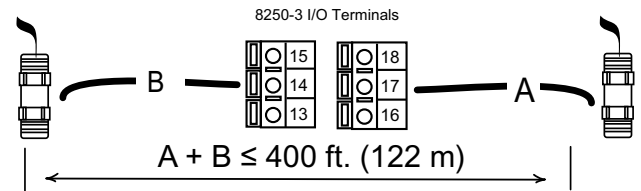

Wire two sensors in series for maximum cable distance.

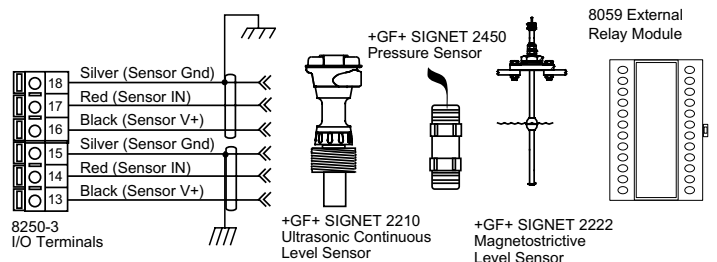

5. System Configuration

The 8250 Level Transmitter is capable of accepting input from a variety of continuous level sensor types. This versatility, plus sensor monitoring options, makes necessary the following system configuration procedure.

1. Determine where you want the level measurement to start. This is the Zero reference point (Z).
Review the diagrams for your sensor type to help select the best option.
2. Determine where you will mount the sensor. This is S_{Loc} .
Consult the Sensor manual for information regarding the best location for the sensor.
3. Measure the distance between Z and S_{Loc} . This is **O(ffset)**.
4. Enter the Offset into the Calibrate menu.

Zero reference point (Z):

Definition:

The point in the vessel where you want the 8250 to display zero (0 ft., 0 gal. etc).

- If Z is located below the fluid surface, the 8250 will display a positive level measurement.
- If Z is located above the fluid surface, the 8250 will display a negative level measurement.

Sensor Location point (S_{Loc}):

Definition:

The point on the level sensor where the measurement is taken.

- Magnetostrictive level sensors measure from the bottom of the stick.
- Pressure sensors measure from the centerline of the diaphragm.
- Ultrasonic level sensors measure from the flat transducer face.

Offset (O):

Definition:

The distance from the zero reference point (Z) to the sensor location point (S_{Loc}).

- Enter a positive value in the Calibrate menu if the sensor is located above Z (zero reference point).
- Enter a negative value in the Calibrate menu if the sensor is located below Z (zero reference point).
- Enter 0 in the Calibrate menu if the sensor is located at Z (zero reference point).

Level (L):

Definition:

- The distance from Z (zero reference point) to surface of fluid (displayed as "Level" by transmitter).

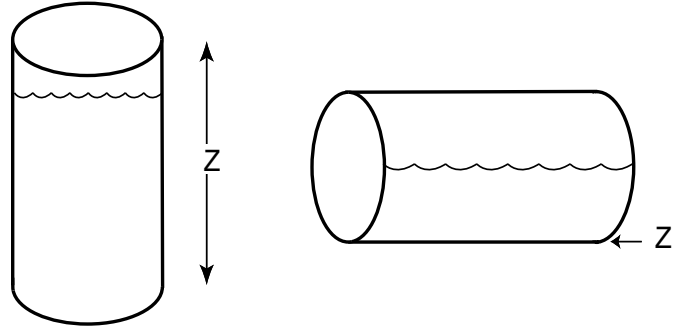

For most vessels, the zero reference point may be designated as any height in the vessel.

For horizontal cylinders only, the zero reference point **MUST** be the lowest point in the vessel.

2210 Ultrasonic Sensor Location and Offset

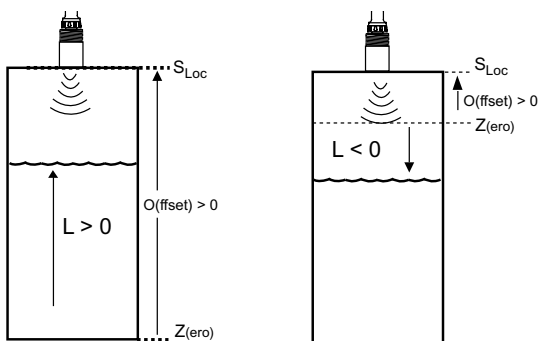

2450 Pressure Sensor Location and Offset

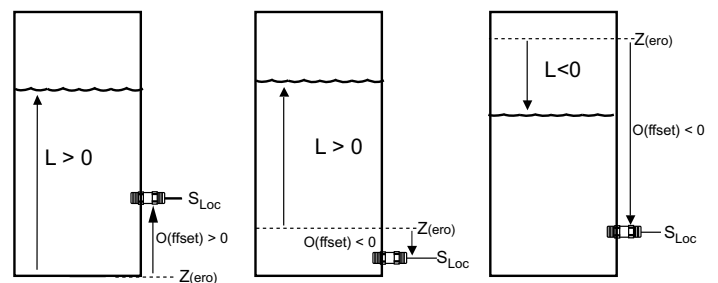

5.1 Level and Volume conversion in custom shaped vessels

If you select Custom Shape in the Options menu, you can define from 2 to 10 Custom Points to establish the relationship of level to volume in the vessel.

- Select Manual level Measurement mode to edit both level and volume data (dry configuration).
- Select Automatic level Measurement mode to accept the sensor measurement of the Level, while you assign a volumetric value to each custom point (wet configuration).
- Enter from 2 to 10 custom points to link level and volume values.
- The first custom point must be the lowest fluid level in the vessel.
- Each successive point must be greater than the preceding point.
- The last point must be equal to or greater than the highest fluid level in the vessel.
- A custom point should be located at all transition points in the vessel shape (for example, at custom point #9, where the shape changes from a cylinder to a cone).
- The more complex sections should be defined with more points. Notice that the conical section of the illustration has been defined by custom points 1 through 9.
- Simpler sections require fewer defining points. Note that the cylinder requires only custom points 9 and 10.

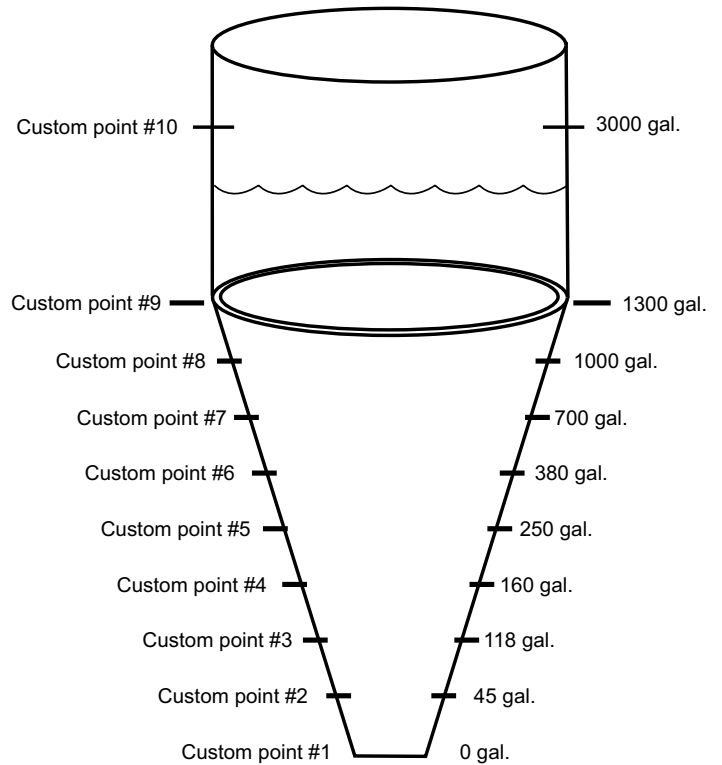

5.2 Reference

Level, volume and mass calculations performed by the 8250 include:

Pressure to level conversion:

$$\text{Level} = P \div (SG \cdot D_{(\text{water})})$$

where P = Pressure

SG = Specific Gravity of fluid

$D_{(\text{water})}$ = Density of water

With pressure in psi: Level (meters) = $(0.703069 \cdot P / SG)$

with pressure in bar: Level (meters) = $1.019715 \cdot P / SG)$

Mass conversion

$$m = D_{(\text{water})} \cdot SG \cdot V$$

where m = mass of fluid

$D_{(\text{water})}$ = Density of water = 1000 kg/m³

SG = Specific Gravity of fluid

V = Volume of fluid (m³)

$$m \text{ (kg)} = 1000 \cdot SG \cdot V$$

Volume calculations

Vertical cylinder: $V = \pi \cdot d^2 \cdot h / 4$

where d = diameter of cylinder
h = height of fluid

Rectangular vessel: $V = w \cdot l \cdot h$

where w = width
l = length

Horizontal cylinder: $V = A \cdot L$

where A = area of segment
L = Length of vessel

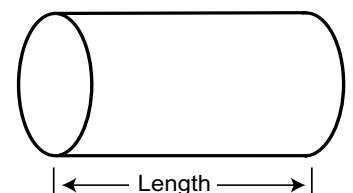
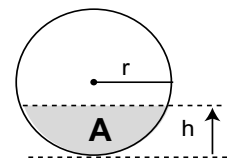

Custom vessel:

The 8250 performs linear interpolation between adjacent points.

5.3 Relay Operation

Relay outputs can be used as switches that respond when the process variables move above or below setpoints, or when the process variables move outside of a window.

- The relays may be turned Off if not in use.
- Response can be delayed up to 6400 s (see Calibrate menu).

Low:

Relay is energized when process variable is less than the setpoint. The relay relaxes when the process variable moves above the setpoint plus the hysteresis value.

High:



Relay is energized when process variable is greater than the setpoint. The relay relaxes when the process variable moves below the setpoint plus the hysteresis value.

Window

Relay is energized when the process variable moves above or below a fixed window of values. The relay relaxes when the process variable moves inside the window by more than the hysteresis value.

Note:

Relays will operate in reverse if miswired. Observe relay logic appropriate to the application.

Relay energized 
Relay relaxed 

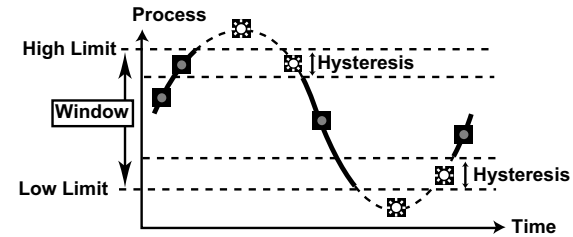
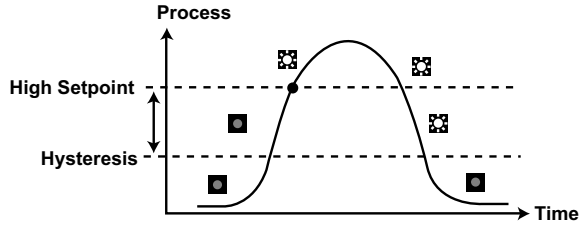
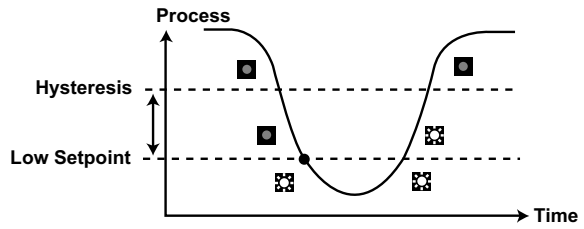

6. VIEW menu

- During normal operation, the ProcessPro displays the VIEW menu.
- To select a display, press the UP or DOWN arrow keys. The display selections scroll in a continuous loop.
- Changing the display selection does not interrupt system operations.
- No keycode is necessary to change display selection.
- Output settings cannot be edited from the VIEW menu.
- When using the CALIBRATE or OPTIONS menus, the ProcessPro will return to the VIEW menu if no key is pressed for 10 minutes.



View Menu

Display	Description
---------	-------------

The following displays are permanent. They will remain as selected until you change them.

LVL1: 10.000 ft LVL2: 20.000 ft	Displays Level 1 and Level 2 values simultaneously when "Level" is selected in the Options menu.
------------------------------------	--

VOL1: 300.00 gal VOL2: 400.00 gal	Displays Volume 1 and Volume 2 values simultaneously when "Volume" is selected in the Options menu.
--------------------------------------	---

LVL1: 10.000 ft VOL1: 300.00 gal	Displays Level and Volume values simultaneously for Channel 1 or Channel 2 when "Both" is selected in the Options menu.
LVL2: 20.000 gal VOL2: 400.00 gal	

These displays are temporary. The permanent display will return after ten minutes.

Loop 1 19.00 mA Loop 2 20.00 mA	Displays Loop 1 and Loop 2 (4-20 mA) outputs
------------------------------------	--

Relay A: On Relay B: Off	Displays the status of Relays A and B. Appears only when external relay module is detected.
-----------------------------	---

No Relay Module Detected	Displayed if the relay module is not detected at Sensor Configuration (see calibrate menu).
--------------------------	---

Last Cal: 03-17-02	Displays the date for scheduled maintenance or date of last calibration.
--------------------	--

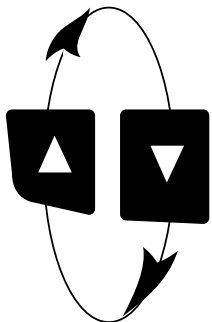

7. ProcessPro Editing Procedure:

Step 1. Press and hold ENTER key:

- 2 seconds to select the CALIBRATE menu
- 5 seconds to select the OPTIONS menu.

Step 2. The Key Code is UP-UP-UP-DOWN keys in sequence.

- After entering the Key Code, the display will show the first item in the selected menu.

Step 3. Scroll menu with UP or DOWN arrow keys.

Step 4. Press RIGHT ARROW key to select menu item to be edited.

- The first display element will begin flashing.

Step 5. Press UP or DOWN keys to edit the flashing element.

- RIGHT ARROW key advances the flashing element.

Step 6. Press ENTER key to save the new setting and return to Step 3.

Notes on Step 1:

- The View Menu is normally displayed.
- The CALIBRATE and OPTIONS menus require a KEY CODE.

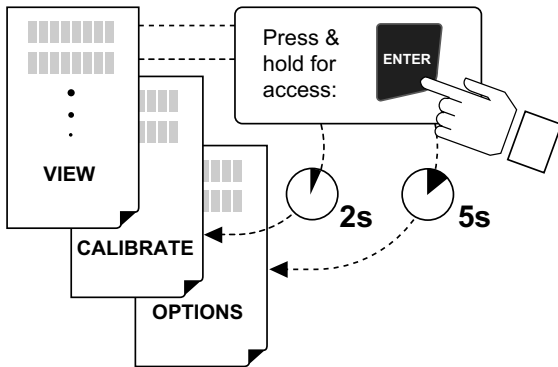

Notes on Step 2:

If no key is pressed for 5 minutes while display is showing "Enter Key Code", the display will return to the VIEW menu.

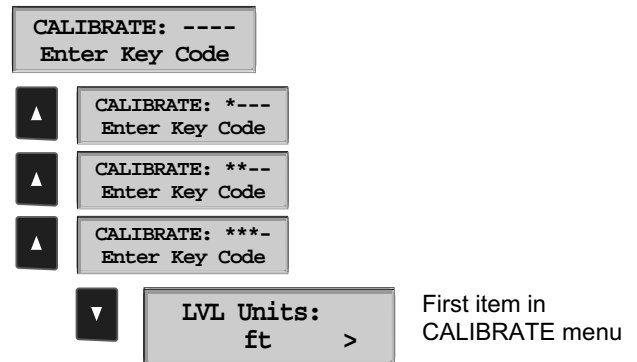

Notes on Steps 3 and 4:

- Refer to pages 8-10 for complete listing of menu items and their use.
- From the Step 3 display, pressing the UP and DOWN keys simultaneously will return the display to the VIEW menu.
- If no key is pressed for 10 minutes, display will also return to the VIEW menu.



Step 3: Finished Editing?
Press the UP and DOWN keys simultaneously after saving the last setting to return to normal operation.

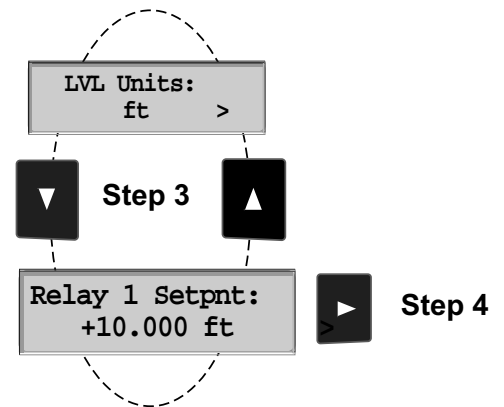

Notes on Steps 5 and 6:

- All output functions remain active during editing.
- Only the flashing element can be edited.
- RIGHT ARROW key advances the flashing element in a continuous loop.
- Edited value is effective immediately after pressing ENTER key.
- If no key is pressed for 10 minutes unit will restore the last saved value and return to step 3.
- Step 6 (pressing ENTER key) always returns you to Step 3.
- Repeat steps 3-6 until all editing is completed.

Step 5: Made an Error?

Press the UP and DOWN keys simultaneously while any element is flashing. This will recall the last saved value of the item being edited and return you to Step 3.



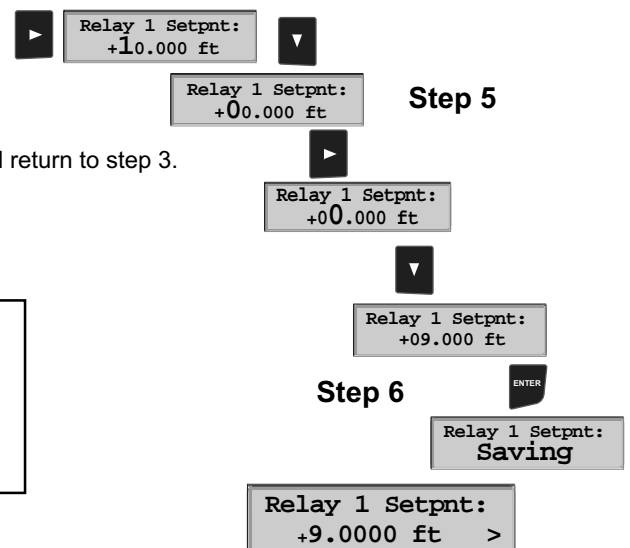

8. Calibrate Menu

Display (Factory settings shown)	Description
LVL1 Units: ft >	Select the units of measure: ft, in, m,cm.
Show LVL1 in %: No >	Yes: Level will be displayed as a percentage of the full scale. No: Level will be displayed as engineering units.
LVL1 100%: +0.0000 ft >	If "Show LVL in %" is YES, enter the full scale value. The units are the same as LVL Units
Sensor 1 Offset: +0.0000 ft >	Enter the distance from sensor location to the Zero reference point in the vessel. Enter + if the sensor is located above the Zero reference point. Enter - if the sensor is located below the Zero reference point.
VOL1 Units: gal >	Select the units of measure for Volume: gal, ft ³ , in ³ , m ³ , kg, lb, or lit (liters)
Show VOL1 in %: No >	Yes: Volume will be displayed as a percentage of the full scale. No: Volume will be displayed as engineering units.
VOL1 100%: +0.0000 gal >	If "Show VOL in %" is YES, enter the full scale value. The units are the same as VOL Units
Spec Gravity: 1.0000 >	Enter the specific gravity of the fluid. Factory setting is 1 (water) This setting is required if the level measurement is made by a pressure sensor (+GF+ SIGNET 2450), or if volume units are selected (kg or lb) .
Set LVL1: >	Single-point calibration for Level1
Reset LVL1 to Factory Cal: >	Yes: Reset Level to original factory calibration. ("Set LVL1" entry is erased.) No: Return to menu, do not reset Level.

Settings will repeat for Level #2 and Volume #2.

8. Calibrate Menu (continued)

Display (Factory settings shown)	Description
Loop 1 Source: LVL1 >	Select the source for the 4-20 mA Loop: LVL1, LVL2,r VOL1 or VOL2.

Loop 1 Rng: ft +0.0000 → +10.000 >	Select the minimum and maximum values for the 4-20 mA Current loop output.
---------------------------------------	--

Settings will repeat for Loop 2

Relay 1 Mode: Off >	Select the mode of operation for Relay Output: Low, High, or Window. The relay may be disabled (Off) if not in use.
------------------------	---

Relay settings below will not appear if the Relay mode is OFF

Relay 1 Source: LVL >	Select the source for Relay: LVL1, LVL2, VOL 1 or VOL2.
--------------------------	---

Relay 1 Setpnt: +0.0000 ft >	If Relay is in Low or High mode, the relay will be activated when the level or volume reaches this value.
---------------------------------	---

Relay 1 Rng: ft +0.0000 → +10.000 >	If Relay is in Window mode, the relay will be activated when the level or volume is less than or greater than the range. <u>You must enter the low limit into the first field, and the high limit into the second field.</u>
--	--

Relay 1 Hys: 0.0000 ft >	Relay will be deactivated at Setpoint ± Hysteresis. The Hysteresis value is in Level units or % of full scale.
-----------------------------	--

Relay 1 Delay: 0.0 secs >	Set up to 6400 seconds delay time for relay response. Relay will be activated only if the source value exceeds the setpoint for this time period.
------------------------------	---

Relay settings will repeat for Relay #2 and for External relays A and B.

A and B Relays require the optional External Relay Module (model number 3-8059)

Switch Sensor ID (CAUTION!) >	Reverses the identification of Sensor inputs: SENSOR 1 becomes identified as SENSOR 2, SENSOR 2 becomes identified as SENSOR 1. Use this function to make adjustments according to the requirements of your system
----------------------------------	--

Reset Sensor Configuration: >	Use this function during initial startup of a new system, and whenever a new device is added to the system. It enables the 8250 to scan the sensor input terminals and determine the type and specific serial numbers of the sensors connected to the sensor input.
----------------------------------	---

Last Cal: 03-17-02 >	Use this "note pad" to record important dates, such as annual recertification or scheduled maintenance.
-------------------------	---

9. Options Menu

Display (Factory settings shown)	Description
Contrast: 3 >	Adjust the LCD contrast for best viewing. A setting of 1 is lower contrast, 5 is higher. In general, select lower contrast if the display is in warmer ambient surroundings.
Display Option: Level >	Select Level, Volume or Both. This setting will determine the permanent display when the unit is in View mode.
Chan 1 Average: Off >	Off provides near-instantaneous response to measurement changes. Low (4 s averaging) Medium (8 s averaging) or High (32 s averaging) will stabilize the system if your process experiences frequent fluctuations or surface turbulence.
Chan 1 Decimal: ***.** >	Set the decimal to the best resolution for your application. The display will automatically scale up to this restriction. Select *****, *****, **.* or *.*.
Loop 1 Adjust: 4.00 mA >	Adjust the minimum and maximum current output. The display value represents the precise current output. Adjustment limits: <ul style="list-style-type: none"> • The 4.00 mA output can be adjusted from 3.80 mA minimum to 5.00 mA maximum • The 20.00 mA output can be adjusted from 19.00 mA minimum to 21.00 mA maximum • Use these adjustments to match the system output to any external device.
Loop 1 Adjust: 20.00 mA >	
Test Loop 1: >	Press UP and DOWN keys to manually order any output current value from 3.6 mA to 21.00 mA to test the output loop.
Test Relay 1 >	Press UP and DOWN keys to manually toggle Relay #1 Off and On.

Relay settings will repeat for Relay #2 and for external Relays A and B.

The following entries are used by the 8250 to convert the level into volumetric and mass measurements. The accuracy of the entries will determine the accuracy of the volumetric and mass calculation. Refer to section 5 for additional information.

VOL1 Shape: Vert Cylinder >	Select the shape of the vessel where Sensor is located: Vert Cylinder, Horiz Cylinder, Rectangular or Custom
VOL1 Diameter: 0.0000 ft >	If Vert Cylinder or Horiz Cylinder is selected: Set the diameter of the cylinder The unit of measure is set by "LVL Units" in Calibrate menu.
VOL1 Length: 0.0000 ft >	If Horizontal Cylinder or Rectangular shape is selected: Set the length of the vessel. The unit of measure is set by "LVL Units" in Calibrate menu.
VOL1 Width: 0.0000 ft >	If Rectangular shape is selected: Set the width of the vessel. The unit of measure is set by "LVL Units" in Calibrate menu.
Number of Custom Points: 10 >	If Custom shape is selected, enter the number of manual calibration points to be entered. Minimum is 2 points, maximum is 10 points.
LVL Measurement: Manual >	If Custom shape is selected: select Manual or Automatic level measurement. Manual allows you to Edit both the Level measurement and the Volume measurement. Automatic allows you to Edit only the Volume measurement (While displaying the Level measurement)
P01: -0.0000 ft V: -0.0000 gal >	Set the Volume (and Level if manual measurement is selected) at each custom point in your vessel.

10. Troubleshooting

Display Condition	Possible Causes	Suggested Solutions
"Value must be 6400 or less"	Time delay cannot be greater than 6400 s.	Set time delay to a 6400 s or less.
"Value must be more than zero"	Specific gravity value set to 0.0000	Set Specific gravity to a value greater than 0.
"Must have more than 1 point" "Must have 10 or less points"	Custom Shape requires from 2 to 10 custom points.	Set number of custom shape points to a value from 2 to 10.
"Must be > than previous point"	A custom point has been entered that is not greater than the previous point. (Custom points must be in ascending order.)	Reset the custom point to a value greater than the preceding point.
"CustomTable Error"	Number of custom points increased without setting new values so all custom points are not sequential.	Review all custom points and reset values so each point is greater than the preceding point.
"CHK SENSOR" appears in VIEW mode "Too Much Error Check Sensor" appears during "SET LVL1" in Calibrate menu "0 SENR(S) FOUND: SAVE ?" appears during "Reset Sensor Configuration" in Calibrate menu	Sensor-related problem during different operational modes: 1. Wiring problem: • AUXILIARY POWER is not connected • The sensor is not connected properly • The sensor wiring is loose 2. The sensor has not been configured ("CHK SENSOR" and "Too Much Error") 3. The sensor is defective	1. Check all wiring, especially AUX POWER 2. "RESET SENSOR CONFIGURATION" in CALIBRATE menu. 3. Replace the sensor, then RESET SENSOR CONFIGURATION.
"No Relay Module Found"	<ul style="list-style-type: none"> • External Relay Module wiring is loose • Relay module has been disconnected • Relay module has been replaced • Relay module is defective 	<ol style="list-style-type: none"> 1. Check wiring 2. RESET SENSOR CONFIGURATION 3. Replace External Relay Module.

Ordering Information

Mfr. Part No.	Code	Description
3-8250-3	159 000 768	Dual Channel Level Transmitter, Field Mount
3-8250-3P	159 000 769	Dual Channel Level Transmitter, Panel Mount
3-8059-2	159 000 770	External Two-Relay Module
3-8059-2AC	159 000 771	External Two-Relay Module w/Power Supply

Accessories

Mfr. Part No.	Code	Description
3-8050	159 000 184	Universal mounting kit
3-8050.395	159 000 186	NEMA 4X Back Cover
3-8052	159 000 188	3/4" Integral mounting kit
3-8050.396	159 000 617	RC Filter Kit (for relay use), 2 per kit
3-0000.596	159 000 641	Heavy Duty Wall Mount Bracket
3-9000.392	159 000 368	Liquid-tight connector kit, 3 sets, 1/2 in. NPT5
3-9000.392-1	159 000 839	Liquid-tight connector kit, 1 set, 1/2 in. NPT5
3-9000.392-2	159 000 841	Liquid-tight connector kit, 1 set, PG 13.5
7300-7524	159 000 687	7.5W 24V Power Supply
7300-1524	159 000 688	15W 24V Power Supply
7300-3024	159 000 689	30W 24V Power Supply
7300-5024	159 000 690	50W 24V Power Supply
7300-1024	159 000 691	100W 24V Power Supply

+GF+ SIGNET

Signet Scientific Company, 3401 Aerojet Avenue, El Monte, CA 91731-2882 U.S.A. • Tel. (626) 571-2770 • Fax (626) 573-2057
For Worldwide Sales and Service, visit our website: www.gfsignet.com • Or call (in the U.S.): (800) 854-4090

GEORGE FISCHER +GF+ Piping Systems
3-8250.090-3/(A-8/01) English

© Signet Scientific Company 2001

Printed in U.S.A. on recycled paper

