



3-5700.090-1



(G-8/99), English/pH



CAUTION!

- Refer to instruction manual for more details.
- Remove power to unit before wiring input and output connections.
- Follow instructions carefully to avoid personal injury.

Contents

- | | |
|---|------------------------------------|
| 1. Power Connections | 7. Parts and Accessories |
| 2. Compatible Electrode/Preamp Wiring | 8. Specifications |
| 3. 4 - 20 mA Current Output Connections | 9. Quick Reference Menu Parameters |
| 4. Relay Connections | 10. Troubleshooting |
| 5. Relay Operation | 11. Maintenance |
| 6. Menu Functions | |

1. Power Connections



CAUTION!

Never connect 110 VAC or 220 VAC to rear power terminals. High voltage AC will damage instrument and void warranty.

= Double Insulated
 = DC or AC power

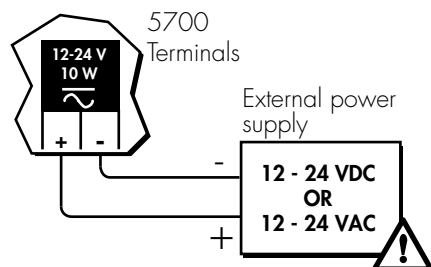

Technical Notes:

- To reduce the possibility of noise interference, isolate AC power lines from signal lines.
- Maximum 4-20 mA loop impedance (sec. 3) is affected by the supply voltage.

2. Compatible Electrode/Preamp Wiring

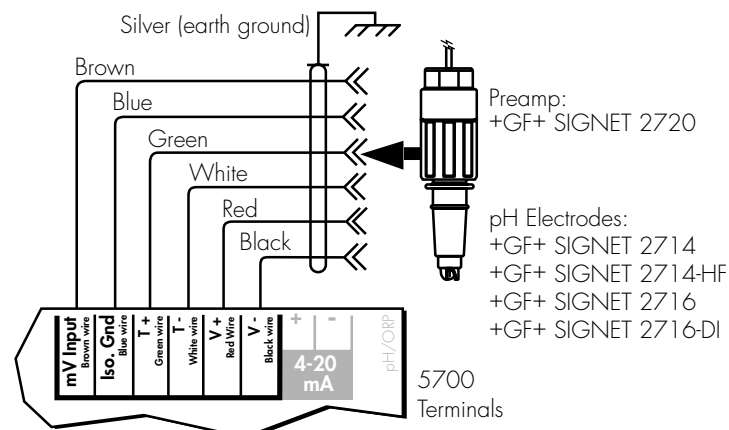

Technical Notes:

- Use six conductor shielded cable for cable extensions up to 120 m (400 ft) max. (#5523-0064)
- Cable shield must be maintained through cable splice

3. 4-20 mA Current Output Connections

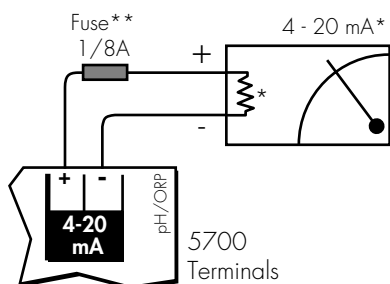

Technical Notes:

- ** 1/8A fuse recommended (customer supplied)
- * 4-20 mA output is **internally powered** (non-isolated), maximum loop impedance 350 Ω with a 12 V instrument supply voltage, 950 Ω with a 24 V instrument supply voltage.

To isolate output and prevent ground loop problems:

1. Use monitor device with isolated inputs, or
2. Use separate DC supply for 5700 and monitor device, or
3. Power 5700 with 12 - 24 VAC step down transformer

4. Relay Connections

Two internal relay contact sets (COM, NO, and NC) may be used for external device control. Front panel LED annunciators indicate the activation status of each relay. Each relay can control up to two devices simultaneously, as shown. Relay operation modes include Low alarm, High alarm, and Proportional Pulse (sec. 5).

Common device connections include:

- Pulse mode - metering pump control
- Pulse mode - solenoid valve control
- Low or High mode - warning lamps
- Low or High mode - bells or sirens
- Low or High mode - external heavy-duty relay

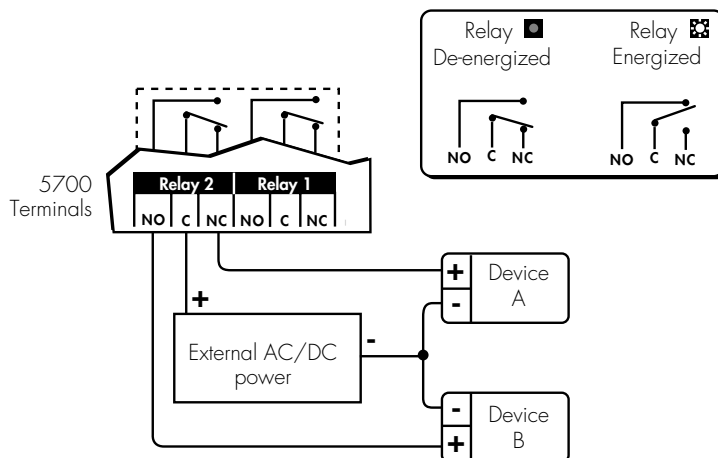

Wiring Example Right

Device A **IS** powered when relay 2 is de-energized (front panel LED "off"). Power is discontinued when the relay 2 setpoint is reached (front panel LED "on"). Device B **IS NOT** powered when the relay 2 is de-energized. Power is applied after the relay 2 setpoint is reached.

Technical Notes:

- Maximum relay contact ratings: 5 A @ 30 VDC, 5 A @ 125 VAC, or 3 A @ 250 VAC
- An external heavy-duty relay must be used for devices with surge currents or operating currents that exceed the above specifications.

5. Relay Operation

A. LOW alarm mode

The relay is energized when the pH drops below the setpoint, and is de-energized when the pH rises above the setpoint plus hysteresis (sec. 6.3E, 6.3F).

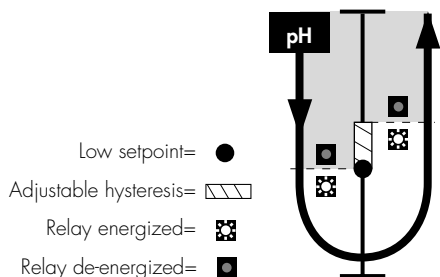

B. HIGH alarm mode

The relay is energized when the pH rises above the setpoint and is de-energized when the pH falls below the setpoint plus hysteresis (sec. 6.3E, 6.3F).

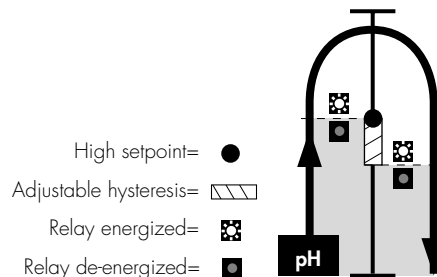

C. Proportional PULSE mode

The proportional pulse relay configuration is primarily designed for metering pump control. The operator is prompted to enter a minimum and maximum pH setpoint and maximum pulse rate for the assigned relay (sec. 6.3G, 6.3H). Relay pulse width is fixed at 130 ms. Refer to the operation examples below.

- Metering pump chemical addition (dry contact activation type required)

Example 1 (right):

As the process pH rises above the minimum pulse setpoint (4.00 pH) the relay begins pulsing; triggering the metering pump for chemical addition. As the pH continues to rise, pulsing accelerates proportionally until the maximum programmed pulse rate of 300 pulses/minute and setpoint (10.00 pH) are reached, forcing the process pH back down to intended levels (e.g. ≤ 4.0 pH).

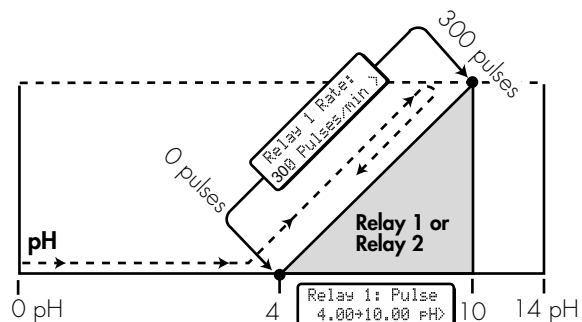

Example 2 (right):

As the process pH falls below the minimum pulse setpoint (10.00 pH) the relay begins pulsing; triggering the metering pump for chemical addition. As the pH continues to decrease, pulsing accelerates proportionally until the maximum programmed pulse rate of 300 pulses/minute and setpoint (4.00 pH) are reached, forcing the process pH back up to intended levels (e.g. ≥ 10.0 pH).

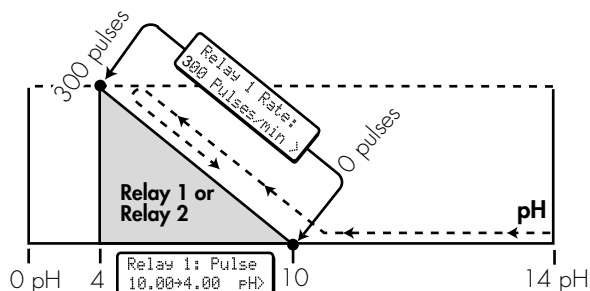

6. Menu Functions

To access either CALIBRATE or OPTIONS menus, press and hold the ENTER key as illustrated below:

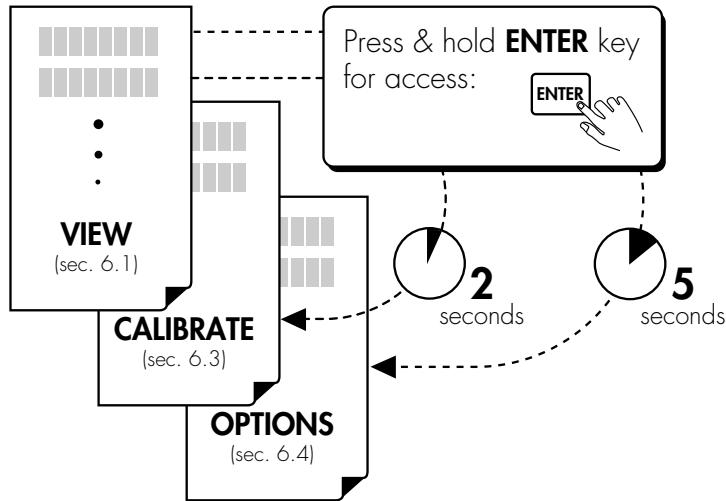

Menus:

- **VIEW menu (sec. 6.1):** The VIEW menu is displayed during standard operation. The operator can navigate freely through the menu by pressing either UP or DOWN arrow keys.
- **CALIBRATE Menu (sec. 6.3):** The CALIBRATE menu contains all critical display setup and output parameters. A simple security code feature prevents unauthorized tampering. The operator is required to enter a simple access code for menu access. The same code also unlocks OPTIONS menus.
- **OPTIONS Menu (sec. 6.4):** The OPTIONS menu contains setup and display features that are seldom accessed for minor display or output adjustments.

- **Reversible Dial**
Your 5700 includes a reversible dial face for ORP use. See enclosed ORP manual for operation details.

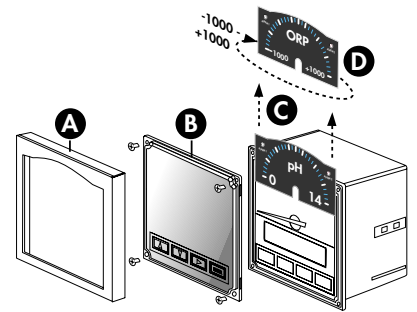

6.1 VIEW Menu

| 1 Choose: | 2 Change: | 3 Save: |
|--|--|------------|
| <p>7.04 pH +25.0 °C pH/temperature</p> <p>Input: -3 mV mV input</p> <p>Loop Output: 12.04 mA Loop output</p> <p>Min→Max: pH 0.00→14.00 Range</p> <p>Relay 1: Low 4.00 pH Relay 1</p> <p>Relay 2: High 10.00 pH Relay 2</p> <p>Last CAL: 01-01-98 Last calibration</p> <p>EASY CAL: > Buffer calibration</p> | | |
| | <p>Press and release to access EASY CAL Procedure</p> | |

See EASY CAL Procedure (Section 6.2)

Menu Displays A - H:

















(Factory default displays shown in menu column 1)

- A. Active pH and temperature display
- B. Input display: shows electrode input mV
- C. Loop output display: shows the loop current output level.
- D. pH range display: shows the programmed min and max meter range (sec. 6.3A)
- E. Relay 1 display: this display shows the programmed operation mode and setpoint for relay 1 (sec. 6.3E)
- F. Relay 2 display: this display shows the programmed operation mode and setpoint for relay 2 (sec. 6.3E)
- G. Last calibration: this display shows a user defined setup date for maintenance records. This feature is not an internal timer or calendar.
- H. EASY CAL: press the right arrow key to access the EASY CAL buffer calibration procedure (sec. 6.2).

6.2 EASY CAL Procedure

Requirements

- This procedure simplifies system calibration using standard pH buffers. **Use pH 4.0, 7.0, 10.0 pH buffers only (sec. 7)**. If standard pH buffers are not available, the system can be calibrated using the CALIBRATE menu temperature, standard, and slope settings (sec. 6.3B-D).
- Access CALIBRATE menu (sec. 6.3B) and set sensor temperature before performing EASY CAL for new electrode installation.

| | | |
|---|---|---|
| <p>EASY CAL: ---- Press keys in sequence     to continue, Enter Key Code **** will appear during code entry.</p> | | |
| <p>1 To Calibrate:</p> | <p>2 Response:</p> | <p>3 To Accept:</p> |
| <p>Place Sensor in pH Buffer #1</p> <p>Place electrode tip in first pH buffer;</p> <p>pH 4.0, 7.0 or 10.0</p>  | <p> 6.90 pH -005 mV</p> <p>Allow for stabilization</p>  <p>30 seconds*</p> | <p> 6.90 pH -005 mV</p> <p>Press  to accept first buffer calibration.</p> <p> 7.00 pH -005 mV</p> |
| <p>Place Sensor in pH Buffer #2</p> <p>Place electrode tip in second (different) pH buffer;</p> <p>pH 4.0, 7.0 or 10.0</p>  | <p> 3.93 pH +179 mV</p> <p>Allow for stabilization</p>  <p>30 seconds*</p> | <p> 3.93 pH +179 mV</p> <p>Press  to accept second buffer calibration.</p> <p> 4.00 pH +179 mV</p> <p>Display returns to VIEW Menu in 3s</p> |
| <p>To exit EASY CAL at any time without saving changes:</p>  quick press | | |

*For best results, gently stir the submerged electrode for approximately 5 seconds during the stabilization period (step 2).

Large temperature differences from process fluids to buffers may require longer stabilization time.

Technical notes:

The difference between the actual mV reading and value shown in the table below is a good indication of the pH electrode condition. Differences in excess of 50 mV indicate a need to service the electrode. Refer to electrode manual for maintenance recommendations.

Theoretical mV values

pH @ 25 °C

| pH @ 25 °C | mV |
|------------|------|
| 2 | +296 |
| 3 | +237 |
| 4 | +177 |
| 5 | +118 |
| 6 | +59 |
| 7 | 0 |
| 8 | -59 |
| 9 | -118 |
| 10 | -177 |
| 11 | -237 |
| 12 | -296 |

6.3 CALIBRATE Menu

Requirements

System calibration is possible with two known pH solutions within 0 to 14 pH and an accurate reference thermometer. The EASY CAL procedure (sec. 6.2) is recommended when standard pH buffers are available. If EASY CAL is performed, manual calibration steps B - D below are not required. Always calibrate solution temperature first (step B below) before setting pH standard and slope (steps C - D below). Single point calibration can be done by setting "Set Standard" (step C) only. Dual point calibration (recommended) can be done by setting "Set Standard" followed by "Set Slope" (steps B-C).

| CALIBRATE: ---- Enter Key Code | | Press keys in sequence to continue, **** will appear during code entry. | | |
|--|---------------------------------|--|-------------------------------------|--|
| 1 Choose: | 2 Change: | 3 Save: | | |
| A. Min→Max: pH 0.00→14.00 > | Min→Max: pH 00.00→14.00 | Min→Max: pH 00.00→14.00 | "SAVING" briefly displays | |
| Range | Meter min→max | | | |
| B. Set Temperature: > | Temperature: +25.0 °C | Temperature: +26.5 °C | | |
| Electrode temp. | Allow for stabilization | | | |
| C. Set Standard: > | Standard: 07.04 pH/ -2 mV | Standard: 07.00 pH/ -2 mV | | |
| Electrode standard | Allow for stabilization | | | |
| D. Set Slope: > | Slope: 04.05 pH/+175 mV | Slope: 04.00 pH/+175 mV | | |
| Electrode slope | Allow for stabilization | | | |
| Relay Low or High Mode Selected | | | | |
| E. Relay 1: Low 4.00 pH> | Relay 1: Low 04.00 pH | Relay 1: Low 02.00 pH | | |
| Relay | Mode Setpoint | | | |
| F. Relay 1 Hys: 1.00 pH> | Relay 1 Hys: 01.00 pH | Relay 1 Hys: 00.50 pH | | |
| Relay | Hysteresis | | | |
| Relay Pulse Mode Selected, step E | | | | |
| G. Relay 1: Pulse 4.00→10.00 pH> | Relay 1 Pulse 04.00→10.00 pH | Relay 1 Pulse 07.00→08.00 pH | | |
| Relay | Mode Range | | | |
| H. Relay 1 Rate: 120 Pulses/min > | Relay 1 Rate: 120 Pulses/min | Relay 1 Rate: 025 Pulses/min | | |
| Relay | Pulse rate | | | |
| I. Last CAL: 01-01-98 > | Last CAL: 01-01-98 | Last CAL: 02-05-98 | | |
| Last calibration | Optional | | | |
| To return to VIEW: | To restore original value: | | | |
| | | | | |

Menu Settings A - 1 :

(Factory default displays shown in menu column 1)

- A. Sets Min → Max meter dial range, 00.00 - 14.00 pH (factory installed dial, 00.00 - 14.00 pH). Contact factory for custom dial configurations. **Does not effect 4 to 20 mA output**
- B. Sets process solution temperature
- C. Sets electrode standard to any value from 0-14 pH. Standard calibration solution must be 2 pH units from slope solution (step D)
- D. Sets electrode slope to any value from 0-14 pH. Slope calibration solution must be 2 pH units from standard solution (step C)

Menu items E - H repeat for relay 2 setup.

- E. Sets relay operation mode Low or High, and setpoint, 00.00 - 14.00 pH (sec. 5A-B)
- F. Sets relay hysteresis, 00.00 - 14.00 pH. Set to zero to disable feature (sec. 5A-B)
- G. Sets relay minimum and maximum pulse setpoint, 00.00 - 14.00 pH (sec. 5C).
- H. Sets relay pulse rate, 000 - 300 pulses/minute.
- I. Sets user defined setup date for maintenance records. This feature is not an internal timer or calendar

Quick Reference Calibration Procedures:

2-Point Quick Calibration (recommended):

1. Verify/enter solution temperature ± 0.5 °C (step B)
2. Set solution standard (step C)
3. Set solution slope (step D)

1-Point Calibration (optional):

1. Verify/enter solution temperature ± 0.5 °C (step B)
2. Set solution standard (step C)

6.4 OPTIONS Menu

| 1 Choose: | | 2 Change: | | 3 Save: |
|--|---|--|-------------------------------|---------|
| OPTIONS: ---- Press keys in sequence to continue, Enter Key Code **** will appear during code entry. | | | | |
| A. Contrast: 3 > | Contrast: 1 2 3 4 5 i 2 3 4 5 Low - - - - High | Contrast: Contrast: Contrast: 1 2 3 4 5 i 2 3 4 5 Low - - - - High | "SAVING" briefly displays | |
| B. Set 4 mA: 0.00 pH > | Set 4 mA: 00.00 pH 4 mA setpoint | Set 4 mA: 02.00 pH 4 mA setpoint | | |
| C. Set 20 mA: 14.00 pH > | Set 20 mA: 14.00 pH 20 mA setpoint | Set 20 mA: 12.00 pH 20 mA setpoint | | |
| D. 4 mA Adjust: 4.00 mA > | 4 mA Adjust: 4.00 mA 4 mA adjust | 4 mA Adjust: 3.88 mA 4 mA adjust | | |
| E. 20 mA Adjust: 20.00 mA > | 20 mA Adjust: 20.00 mA 20 mA adjust | 20 mA Adjust: 19.98 mA 20 mA adjust | | |
| F. Temperature: °C > | Temperature: °C °F Display, °C or °F | Temperature: °C °F Display, °C or °F | | |
| To return to VIEW: quick press | To restore original value: quick press | | | |

Menu Settings A - F:

(Factory default displays shown in menu column 1)

- A. Selects display contrast: 5 levels
- B. Sets 4 mA setpoint: 00.00 - 14.00 pH. 4 mA and 20 mA setpoints are reversible
- C. Sets 20 mA setpoint: 00.00 - 14.00 pH. 20 mA and 4 mA setpoints are reversible
- D. Adjusts 4 mA output: 3.0 to 5.0 mA (overrides factory 4.00 mA calibration)
- E. Adjusts 20 mA output: 19 to 21 mA (overrides factory 20.00 mA calibration)
- F. Selects temperature display: °C or °F. Recalibration is not required when switching from Celsius to Fahrenheit.

7. Parts and Accessories

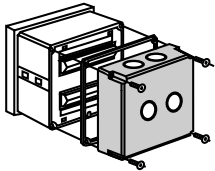

Splashproof rear cover
#3-5000.395
(code 198 840 227)

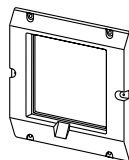

5 x 5 inch adapter plate
for +GF+ SIGNET retrofit
#3-5000.399
(code 198 840 224)

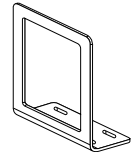

Optional surface mount
bracket #3-5000.598
(code 198 840 225)

- Power supply, 120 VAC - 24 VAC, #3-5000.075
- pH buffer kit, pH 4.0, 7.0, 10.0, #3-0700.390 (code 198 864 403)
- Front snap-on bezel, #3-5000.525 (code 198 840 226)
- 5700 pH/ORP instruction sheet, #3-5700.090-1 (code 198 869 915)

8. Specifications

General

Compatible electrodes: +GF+ SIGNET 3-2720 pH/ORP
Pre-amplifier/Electrode System

Accuracy: $\pm 0.2\%$ of full scale

Input range:

- pH: 0 to 14, optically isolated
(standard 0 - 14 pH dial included)
- Temperature input: 3 k Ω Balco, -25 to 120 °C (-13 to 248 °F), optically isolated

Enclosure:

- Rating: NEMA 4X/IP65 front
- Dimensions: 1/4 DIN, 96 x 96 x 88 mm (3.8 x 3.8 x 3.5 in.)
- Case: ABS plastic
- Keypad: Sealed 4-key silicone rubber
- Weight: Approximately 500 g (18 oz.)

Display:

- Type: Microprocessor controlled air-core meter movement and backlit Alphanumeric 2 x 16 LCD
- Update rate: <1s
- Contrast: User selected
- Relay annunciators: 2 LEDs

Environmental

Operating temp.: -10 to 55 °C (14 to 131 °F), 50 °C (122 °F)
max. with optional rear cover

Storage temp.: -15 to 80 °C (5 to 176 °F)

Relative humidity: 0 to 95%, non-condensing

Altitude: 4000 m max.

Pollution degree: 2

Electrical

Power requirements:

- 12 to 24 VDC or 12 to 24 VAC, unregulated, 50-60 Hz, 10 W max.

Relay contacts (2 sets):

- Mechanical SPDT contacts
- Max. voltage rating: 5 A @ 30 VDC, 5 A @ 125 VAC, or 3 A @ 250 VAC, (power factor = 1.0)
- Hysteresis: User adjustable

Current output:

- 4 to 20 mA, non-isolated, internally powered, fully adjustable and reversible
- Update rate: <1s
- Max loop impedance: 350 Ω with a 12 V instrument supply voltage, 950 Ω with a 24 V instrument supply voltage
- Accuracy: $\pm 0.1\%$ of max. range

Noise immunity: EN50082-2

Noise emissions: EN55011

Safety: EN61010-1

Agency Approvals

- CSA, CE, UL listed
- Manufactured under ISO 9001

Dimensions

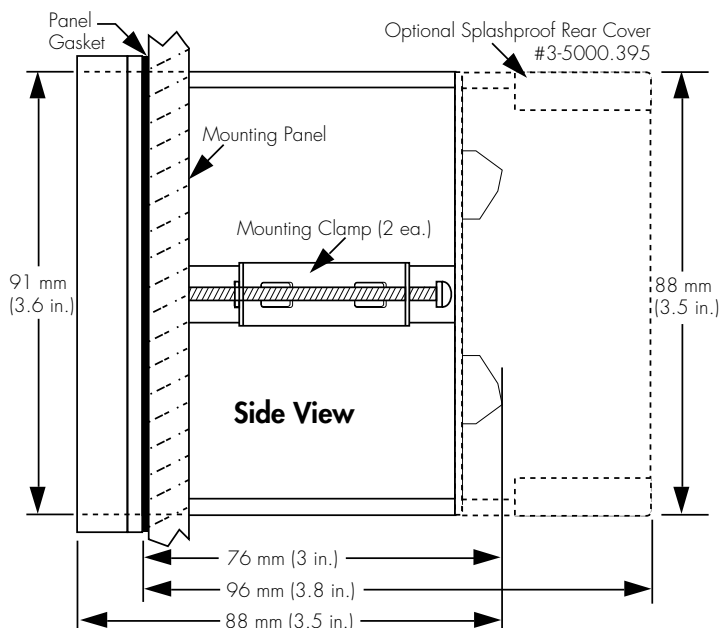
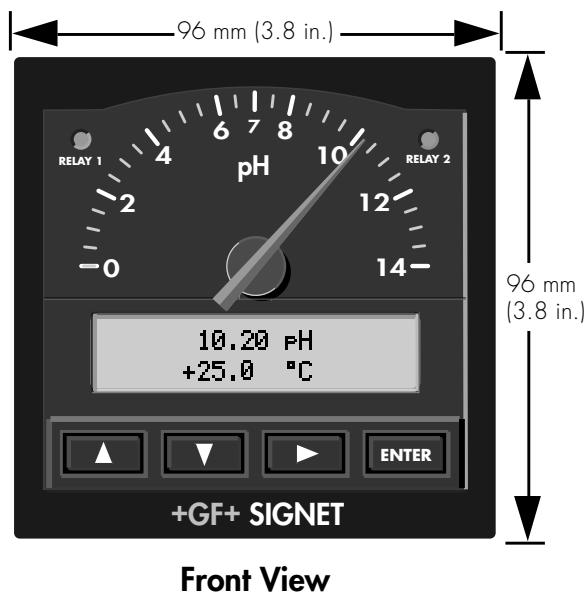

(Continued)

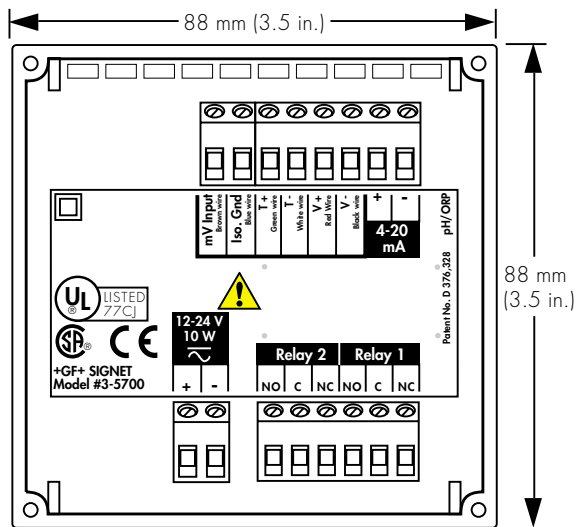

Rear View

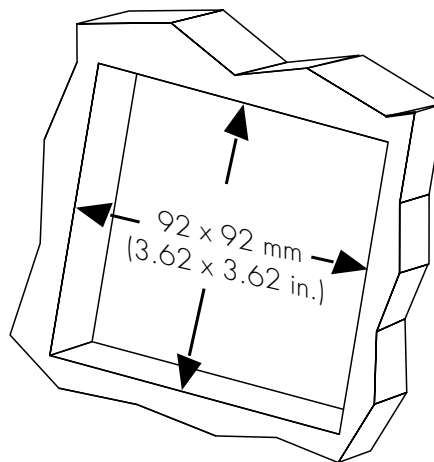

Panel cutout

9. Quick Reference Menu Parameters

9.1 VIEW Menu Setup Parameters (sec. 6.1)

| Menu Parameters | Display Description | Range | Factory Default |
|------------------------------|---|---|------------------|
| A. 7.04 pH +25.0 °C | <ul style="list-style-type: none"> Process pH Process temperature | <ul style="list-style-type: none"> 00.00 - 14.00 pH Process temperature | n/a n/a |
| B. Input: -3 mV | Electrode mV input | -414 - +414 mV | n/a |
| C. Loop Output: 12.04 mA | Current loop output | 3 - 21 mA | n/a |
| D. Min→Max: pH 0.00→14.00 | Min → Max meter and dial range | 00.00 - 14.00 pH | 00.00 - 14.00 pH |
| E. Relay 1: Low 4.00 pH | <ul style="list-style-type: none"> Relay 1 mode Relay 1 setpoint | Low, High, or Pulse, 00.00 - 14.00 pH | Low 4.00 pH |
| F. Relay 2: High 10.00 pH | <ul style="list-style-type: none"> Relay 2 mode Relay 2 setpoint | Low, High, or Pulse, 00.00 - 14.00 pH | High 10.00 pH |
| G. Last CAL: 01-01-98 | Last calibration date | 39 - 39 - 99 | 01 - 01 - 98 |
| H. EASY CAL: > | EASY CAL procedure | Two buffers required: pH 4, 7, or 10 (sec. 6.2) | n/a |

9.2 CALIBRATE Menu Setup Parameters (sec. 6.3)

| | Menu Parameters | Display Description | Range | Factory Default |
|----|-----------------------------------|--|---|----------------------|
| A. | Min→Max: pH 0.00→14.00 > | Min → max meter dial range | 00.00 - 14.00 pH | 00.00 - 14.00 pH |
| B. | Set Temperature: > | Process temperature | Solution temperature ±30 °C (±86 °F) | n/a |
| C. | Set Standard: > | Manual electrode standard calibration | 00.00 - 14.00 pH (must be 2 pH units from Slope) | n/a |
| D. | Set Slope: > | Manual electrode slope calibration | 00.00 - 14.00 pH (must be 2 pH units from Standard) | n/a |
| E. | Relay 1: Low 4.00 pH> | <ul style="list-style-type: none"> • Relay 1 mode • Relay 1 setpoint | Low or High 00.00 - 14.00 pH | Low 4.00 pH |
| F. | Relay 1 Hys: 1.00 pH> | Relay 1 hysteresis | 00.00 - 14.00 pH | 1.00 pH |
| G. | Relay 1: Pulse 4.00→10.00 pH> | <ul style="list-style-type: none"> • Relay 1 mode • Relay 1 range | Pulse 00.00 - 14.00 pH | 4.00 - 10.00 pH |
| H. | Relay 1 Rate: 120 Pulses/min > | Relay 1 pulse rate | 000 - 300 pulses/minute | 120 pulses/minute |
| I. | Last CAL: 01-01-98 > | Last calibration date | 00 - 00 - 00 - 39 - 39 - 99 | 01 - 01 - 98 |

Relay mode and setpoint displays repeat for relay 2 setup

9.3 OPTIONS Menu Setup Parameters (sec. 6.4)

| | Menu Parameters | Display Description | Range | Factory Default |
|----|-----------------------------|------------------------|----------------------------|-----------------|
| A. | Contrast: 3 > | Display contrast | 0 to 5 | 3 |
| B. | Set 4 mA: 0.00 pH > | 4 mA setpoint | 00.00 -14.00 pH | 0.00 pH |
| C. | Set 20 mA: 14.00 pH > | 20 mA setpoint | 00.00 - 14.00 pH | 14.00 pH |
| D. | 4 mA Adjust: 4.00 mA > | 4 mA adjust | 3.0 to 5.0 mA | 4.00 mA |
| E. | 20 mA Adjust: 20.00 mA > | 20 mA adjust | 19 to 21 mA | 20.00 mA |
| F. | Temperature: °C > | Temperature display | °Celsius or °Fahrenheit | °C |

10. Troubleshooting

| Display | Problem | Solution |
|---|--|--|
| 1. ORP: +1000 mV Input: + 998 mV (example↑) | ORP electrode installed in preamplifier | Remove ORP electrode and replace with recommended pH electrode (sec. 2) |
| 2A. Out Of Range CHECK SENSOR | Electrode not installed in preamplifier Temperature input miscalibrated or out of range during power up | 1) Verify temperature input connections and electrode installation (sec. 2) 2) Disconnect Green and White preamplifier wires from rear T+ and T- terminals. Measure resistance across disconnected wires for 2.9 kΩ - 3.1 kΩ at 25 °C (77 °F). If measured resistance is out of range: <ul style="list-style-type: none"> • Wrong electrode installed in preamplifier (ORP electrode=10 kΩ). Replace ORP electrode with pH electrode. • Faulty preamplifier contacts, see preamplifier manual for additional information. • Faulty electrode, see electrode manual for additional information. 3) To verify instrument input: <ul style="list-style-type: none"> • Disconnect Green and White preamplifier wires from rear T+ and T- terminals, then install a 3 kΩ fixed resistor across the terminals. • Power instrument and verify 25 °C (77 °F) on display. If 25 °C (77 °F) is not displayed, calibrate temperature input for 25 °C (sec. 6.3B). • If instrument displays correctly after calibration, instrument is ok. If error condition persists, instrument requires factory service. |
| 2B. CHECK SENSOR? | Temperature input missing or out of range during power up | Refer to solution steps 1 - 3 above. |
| 2C. Temperature Bad CHECK SENSOR | Temperature input missing or out of range during EASY CAL procedure (sec. 6.2) | Refer to solution steps 1 - 3 above |
| 3. Out Of Range Use Manual Cal | pH buffers other than pH 4, 7, 10 used during EASY CAL procedure or electrode has excess offset | <ul style="list-style-type: none"> • Use pH 4, 7, 10 buffers for EASY CAL procedure (sec. 6.2). • Use manual calibration to set standard and slope (sec. 6.3C, 6.3D) • Clean electrode (see electrode manual) then retry EASY CAL (sec. 6.2) |
| 4. ! Same Buffer | Same pH buffer used for EASY CAL buffer 1 and 2 | Use different pH 4, 7, 10 buffer for EASY CAL procedure solution #1 and solution #2 (sec. 6.3). |
| 5. 15.00 pH + 25.0 °C | Excessive mV input from preamplifier | Faulty preamplifier, refer to preamplifier manual for additional information To verify instrument input: <ul style="list-style-type: none"> • Disconnect Brown and Blue preamplifier wires and Install shorting strap (jumper) across mV input and Iso Gnd terminals. • Power instrument and verify 7.00 pH on display. If 7.00 pH is not displayed, calibrate "Set Standard" input for 7.00 pH (sec. 6.3C) • If instrument displays correctly after calibration, instrument is ok. If error condition persists, instrument requires factory service. |

continued

| Display | Problem | Solution |
|---------------------------------------|--|--|
| 6. ! pH Must Be 14.00 Or Less | pH input out of range or improperly entered during Standard or Slope calibration | A) Use two solutions of known pH within 00.00 - 14.00 pH range for manual Standard and Slope calibration (sec. 6.3C, 6.3D). B) Enter pH value only within 0.00 - 14.00 pH during standard or slope calibration (sec. 6.3C - 6.3D) |
| 7. Slope Too Close To Standard | pH slope calibration too close to pH standard calibration | (CALIBRATE Menu sec. 6.3D only) Calibrate pH slope using a pH solution ≥ 2 pH units from the pH standard solution (sec. 6.3C, 6.3D). |
| 8. Value Must Be 14.00 Or Less | Relay, 4 mA, or 20 mA setpoint greater than 14.00 pH | Enter setpoint within 00.00 - 14.00 pH range (sec. 6.3E) |
| 9. Value Must Be 300 Or Less | Relay pulse setting greater than 300 pulses per minute | Enter relay pulse setting within 0 - 300 pulses per minute (sec. 6.3H) |
| 10. SETUP READ ERROR Press any Key | Power fault occurred while saving setup menu entry | Press any key to reload factory defaults then reprogram system setup parameters. |

11. Maintenance

Clean the instrument case and front panel with a soft cloth and a mild liquid soap solution.

Notes:

+GF+ SIGNET

Sales Offices:

- USA** George Fischer, Inc., 2882 Dow Avenue, Tustin, CA 92780/USA, Tel. (714) 731-8800, Fax (714) 731-6201
- Switzerland** Georg Fischer Rohrleitungssysteme AG, P.O. Box 671, CH-8201 Schaffhausen/Switzerland, Tel. 052/631 1111, Fax 052/631 2830
- Singapore** George Fischer Pte. Ltd., 15 Kaki Bukit Road 2, KB Warehouse Complex, Singapore 1441, Tel. 65/747 0611, Fax 65/747 0577
- Japan** Kubota George Fischer, 2-47 Shikitsuhigashi, 1-Chome, Naniwa-Ku, Osaka, 556-91 Japan, Tel. 816/648 2545, Fax 816/648 2565
- China** Georg Fischer Ltd., Rm 1503, Business Residence Bldg. of Asia Plaza, 2-3 Bldg. No. 5th Qu Anzhenxili, Chaoyang Qu, Beijing 100029, P.R. China, Tel. 86/10 6443 0577, Fax 86/10 6443 0578
- Australia** George Fischer Pty. Ltd., Suite 3, 41 Stamford Road, Oakleigh, Victoria 3166, Australia, Tel. 61/3 9568 0966, Fax 61/3 9568 0988

Signet Scientific Company, 3401 Aerojet Avenue, El Monte, CA 91731-2882 U.S.A., Tel. (626) 571-2770, Fax (626) 573-2057

GEORGE FISCHER +GF+ Piping Systems
3-5700.090-1/(G-8/99), English/pH

© Signet Scientific Company 1995



PRINTED ON RECYCLED PAPER
Printed in U.S.A.