

+GF+ SIGNET 2550/2560 Electromagnetic Flow Sensors



Features

2550

- Local Rate Indication
- Fully Scaleable Isolated Current Output
- Pushbutton Programmable
- Fluid Diagnostics
- Frequency Output

2560

- Alarm Relay
- Test Mode

Application

- Waste Effluent Monitor
- Scrubbers
- Raw Water Intake
- Metal Recovery and Landfill Leachate
- RO Feedwater

Description

Rugged construction allows the +GF+ SIGNET magmeters to be installed in piping systems where suspended solids are present. Bipolar pulsed DC drive

prevents galvanic reactions from coating the stainless steel electrodes. Simple insertion offers significant savings over full-bore magnetic flowmeters.

Options

Flow Sensors	Flow Instruments						
	3-5075	3-5091	3-5500	3-5600	3-8550-1	3-8550-2	3-8550-3
2550	●	●	●	●	●	●	●
2560							●

*with 4 to 20mA Input Card

Technical Features

- Insertion flow sensors are designed to accurately sense the mean flow rate in pipes with fully developed turbulent flow.
- The movement of conductive fluid ($>5\mu\text{S}/\text{cm}$) through the sensor's magnetic field generates a perpendicular electromotive force proportional to its velocity.
- Minimal insertion ensures reduced chances of electrode fouling. High impedance bipolar sensing reduces the effects of electrode coating and prevents galvanic reactions.
- Standard NPT or ISO threads allow simple, cost-effective installation.
- 0.2 in. insertion depth means no pressure drop

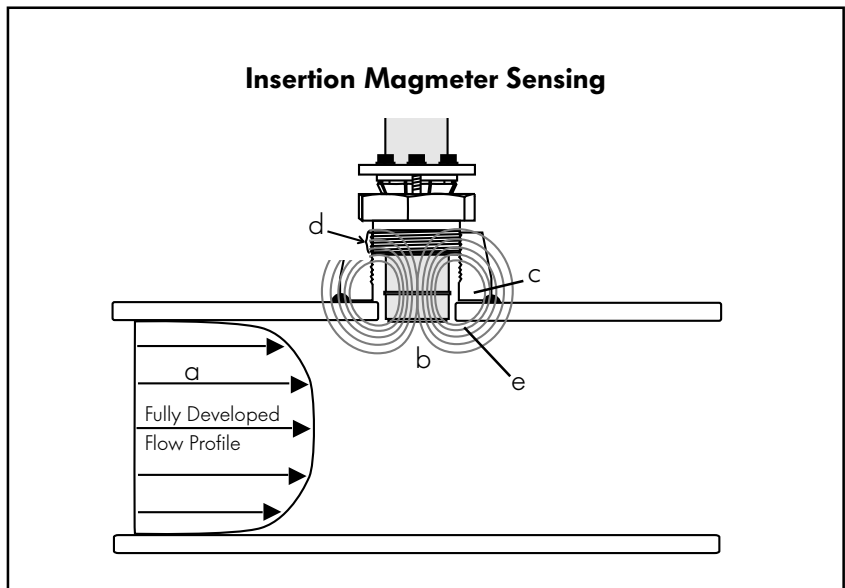

Dimensions 2550

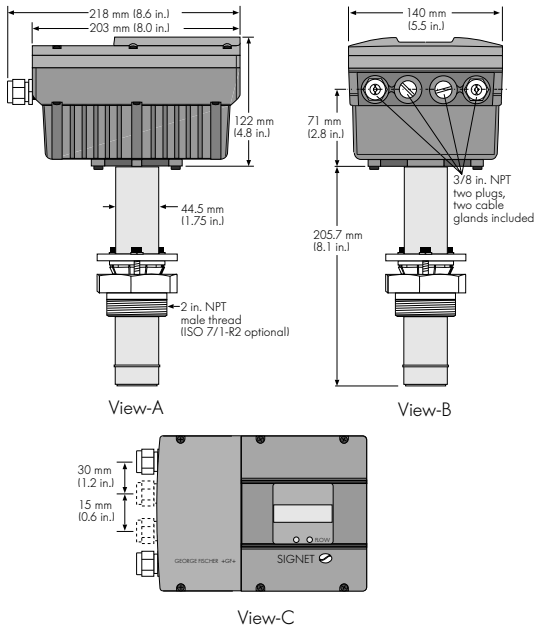

2560

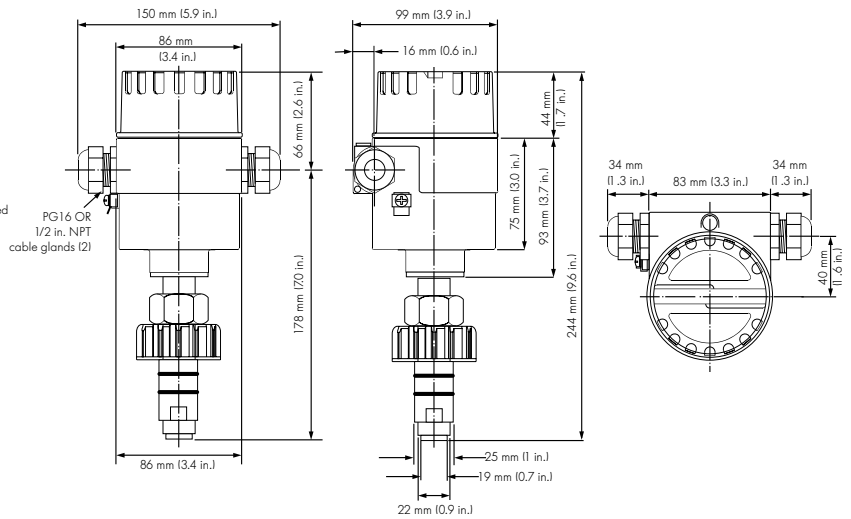

Installation

Six common installation configurations are shown here as guidelines to help you select the best location in your piping system for a magnetic flow sensor. Always maximize the distance between sensors and pump sources.

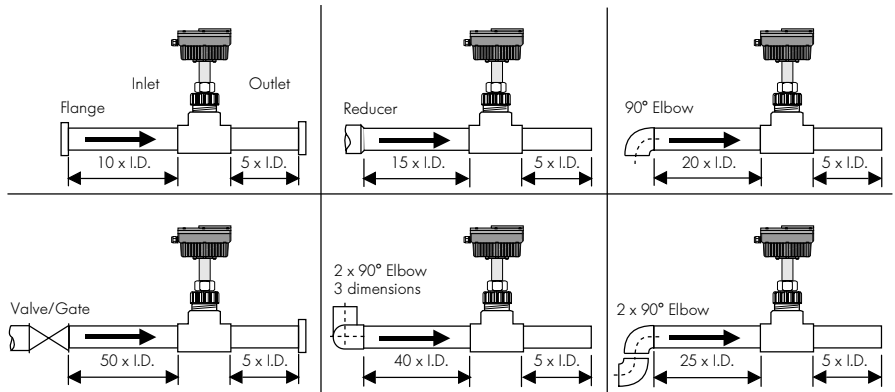

Sensor Mounting Positions

On horizontal pipe runs sensors may be mounted in any position around the pipe. If air bubbles or sediments are expected; mount at a slight angle. On vertical pipe runs sensor must be mounted in lines with UPWARD flow only to ensure a full pipe.

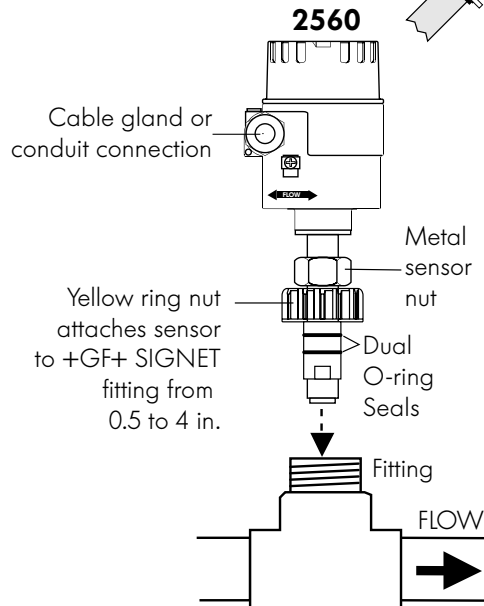
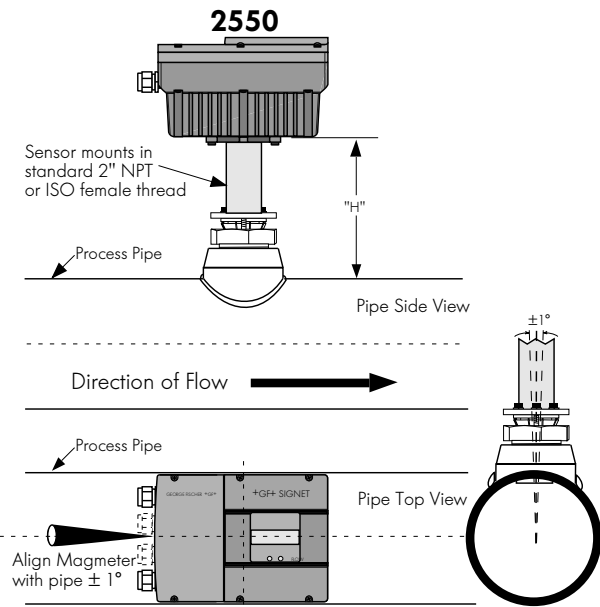
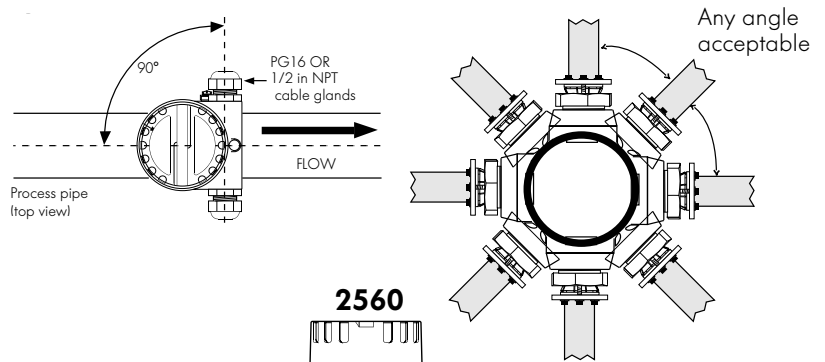

Wiring

2550

Load $R_L = 600\Omega$ Max.

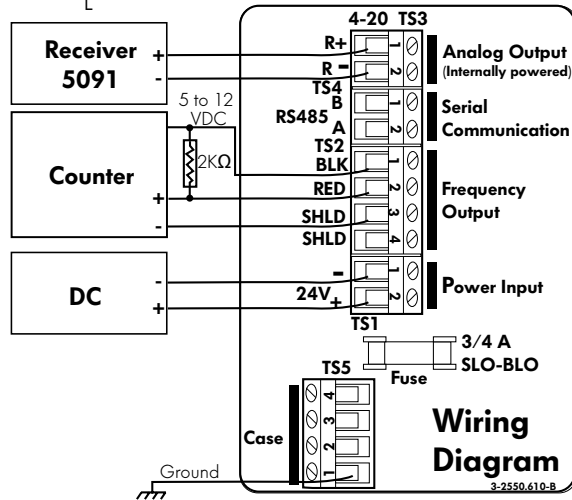

2560

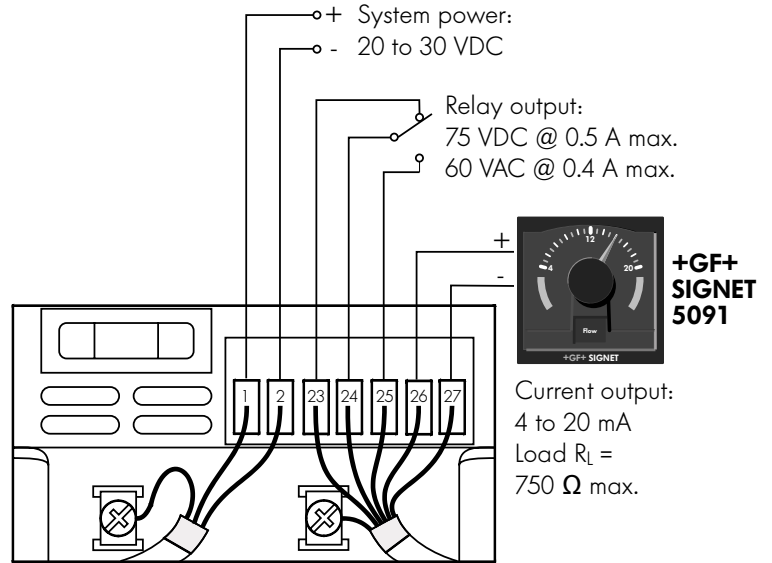

Technical Data

2550

General

Flow Rate Range: 0.1 to 7 m/s (0.3 to 20 ft/s)
 Linearity: $\pm 2\%$ of reading or 0.05 ft/s (whichever is greater)
 Min. Reynolds Number: 4500
 Pipe Size Range: DN50 to DN300 (2 to 12 in.)
 Wetted Materials:
 Sensor Body, Electrodes and Installation Hardware:
 316 SS
 Insulator: PFA
 Internal O-Ring: FPM (Viton)
 Enclosure: NEMA4 die cast aluminum
 Power Requirements: 24 VDC $\pm 10\%$, 600 mA
 Max. Loop Impedance: 600 Ω , isolated
 Frequency Output: 0 to 7m/s (20 ft/s)=0 to 500 Hz isol., open collector, 5 to 12VDC (2K pull-up recommended)
 Fluid Condition:
 Temperature: 0 to 100°C (32 to 212°F)
 Conductance Req'd: 5 μ S/cm
 Maximum Pressure: 17 bar (250 psi)
 Weight: 6 Kg
 Ambient temperature: -20 to 80 °C (-4 to 176 °F)

2560

Flow Rate Range: 0.1 to 7 m/s (0.3 to 20 ft/s)
 Linearity: $\pm 2\%$ of reading
 Min. Reynolds Number: 4500
 Pipe Size Range: DN15 to DN100 (0.5 to 4 in.)
 Wetted Materials:
 Sensor Body, Electrodes and Installation Hardware:
 316 SS
 PVDF
 FPM (Viton)
 Enclosure: NEMA4X aluminum w/e-coat
 Power Requirements: 20 to 30 VDC, 125 mA max.
 Max. Loop Impedance: 750 Ω , non-isolated
 Alarm Contact, SPDT relay
 0.5A @ 75 VDC; 0.4 A @ 60 VAC
 Fluid Condition:
 Temperature: (see chart below)
 Conductance: 20 μ S/cm
 Maximum Pressure: (see chart below)
 Weight: 1.6 Kg

Standards and Approvals:

- Manufactured under ISO 9001
- CE

2560 Max. pressure./temperature ratings:

- 12.5 bar (180 psi) max @ 20°C (68°F)
- 1.7 bar (25 psi) max @ 85°C (185°F)

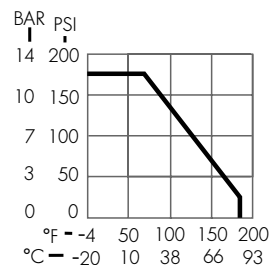

Description

Mfr. Part No.

Code

3-2550.100-110	159 000 294
3-2550.100-110T	159 000 632
3-2550.100-111	198 840 024
3-2550.100-111T	198 840 025
3-2560-1	198 840 031
3-2560-2	198 840 030

Description

Insertion Magmeter with 2 in. NPT Fitting
 Insertion Magmeter with 2 in. NPT Fitting and Installation Tool
 Insertion Magmeter with 2 in. ISO Fitting
 Insertion Magmeter with 2 in. ISO Fitting and Installation Tool
 Flowmag with 0.5 in. NPT Cable Gland Ports
 Flowmag with PG 16 Cable Gland Ports

Accessories

Mfr. Part No.

Code

3-2550.355	159 000 296
1500-0101	159 000 239
6400-0020	159 000 647
1222-0439	159 000 235

Description

Magmeter Installation Tool
 (for 3-2550)
 Cable Connector
 (0.125 to 0.187 o.d.)
 Fuse, Slo-Blo
 Gasket, outer cover

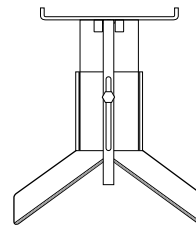

Installation Tool
Front View

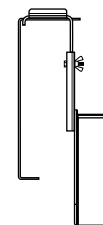

Installation Tool
Side View

Engineering Specification for +GF+ SIGNET 2550 Insertion Magmeter

- The flow sensor shall use magnetic flow sensing technology with no moving parts.
- The sensor shall have a built-in display for calibration and flow rate indication with push button programming and on-board process diagnostics.
- The sensor shall be available in models usable in pipe sizes from 2 to 12 in.
- The sensor shall operate with a power input of 24 VDC \pm 1 0%, 600 mA maximum.
- The sensor outputs shall be an 0/4 to 20 mA internally powered current loop with 600 Ω maximum load, an isolated, open collector pulse train output with 50% duty cycle, in which 500 Hz indicates a 20 ft/sec nominal flow rate, and completely spannable up to 20 ft/sec.
- Measurement linearity shall be \pm 2% of reading or \pm 0.05 ft/s whichever is greater.
- The operating range of the sensor shall accommodate nominal flow rates from 0.1 to 6 m/s (0.3 to 20 ft/s) in fluids with a conductivity of 5 μ S/cm or greater.
- The sensor body shall be made of ACI type CFR-8M (316 SS) per ASTM A351 that shall accommodate working fluid up to 250 psi @ 0 to 100°C (32 to 212°F) in ambient temperatures of -20 to 60°C (-4 to 176°F)
- The sensor tip shall be made of PFA the electrodes shall be 316 SS and the O-rings shall be FPM.
- The sensor shall provide 2.0 in. NPT or ISO 7/1-R2 male pipe threads for insertion installation in plastic or metal piping.
- The sensor shall be sealed to NEMA 4 rating.
- The flow sensor shall be +GF+ SIGNET, Model 2550 Insertion Magmeter.

Engineering Specification for +GF+ SIGNET 2560 Flowmag

- The flow sensor shall use magnetic flow sensing technology in an insertion-style mounting with no moving parts.
- The sensor shall be available in models usable in pipe sizes from 0.5 in. to 4 in. when combined with appropriate installation fittings.
- The sensor shall operate with a power input of 20 to 30 VDC.
- The sensor outputs shall be 4 to 20 mA internally powered current loop with 750 Ω maximum load.
- Measurement linearity shall be \pm 2% of range at measuring electrode.
- The operating range of the sensor shall accommodate nominal flow rates from 0.1 to 7 m/s (0.3 to 20 ft/s) in fluids with a conductivity of 20 μ S or greater.
- Zero flow or an empty pipe condition shall give a stable 4 mA signal.
- A programmable operation SPDT alarm relay shall be capable of switching 0.5 A @ 75 VDC or 0.4 A @ 60 VAC maximum and respond to either flow direction.
- The sensor body shall be made of 316 SS that shall accommodate up to 180 psi @ 20°C (68°F), 25 psi @ 85°C (185°F).
- The sensor tip shall be made of PVDF, the electrodes shall be 316 SS.
- Sensor shall attach to a pipe via a variety of insertion-style installation fittings supplied by the flow sensor manufacturer. Attachment shall use a 1-1/4 X 11- 1/2 NPSM threaded cap. Sealing shall be accomplished with a double O-ring seal. O-rings shall be made of FPM.
- The sensor shall meet appropriate CE standards and shall be sealed to NEMA 4X rating.
- The flow sensor shall be +GF+ SIGNET, Model 2560 Flowmag.