

# +GF+ SIGNET 2507 Mini Flow Sensor



## Features

- Compact Assembly
- Simple Installation
- 1/4" Threaded Connection
- Detachable Signal Connector
- PVDF Construction
- Four Flow Ranges

## Application

- Fluid Dispensing
- Laboratory and Clinical Wet Benches
- Chemical Dosing
- Batch Processes

## Description

The +GF+ SIGNET 2507 Mini Flow Sensor contains a free-running rotor that is driven by the fluid flow. Within the given measurement range, the rotational speed of the rotor is proportional to the fluid flow rate. Permanent magnets built

into the rotor actuate an electronic switch in the top of the sensor generating a square-wave output signal proportional to flow rate. Both opaque and transparent fluids can be measured from 0.2 to 20.0 centistokes.

## Options

Flow Sensor	Instrument Options						
2507	3-5075	3-5500	3-5600	3-8550-1	3-8550-2	3-8550-3	3-9010

## Technical Features

- Removable, sealed electrical connection
- PVDF body and rotor
- 4-magnet rotor
- Viton quad-ring seal
- Inserts for different flow ranges
- G 1/4 or 1/4" NPT tubing or pipe connection adapters included

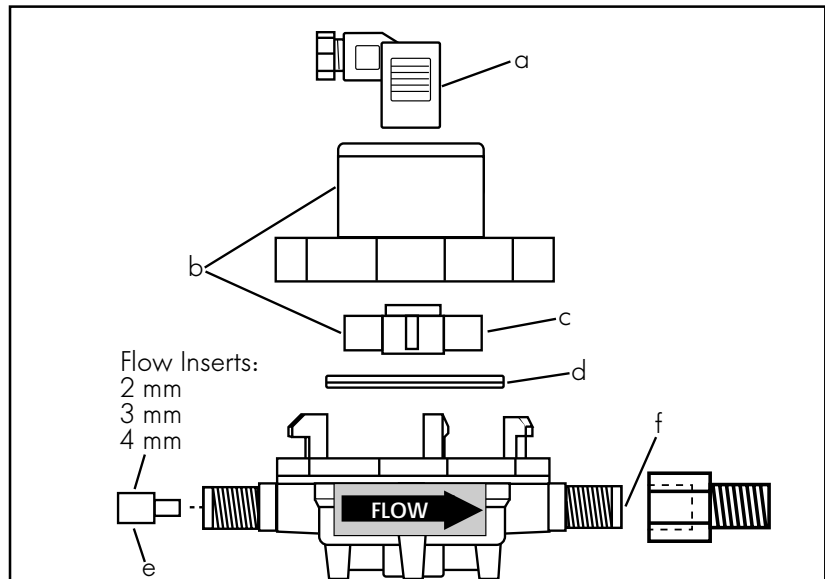

# Dimensions

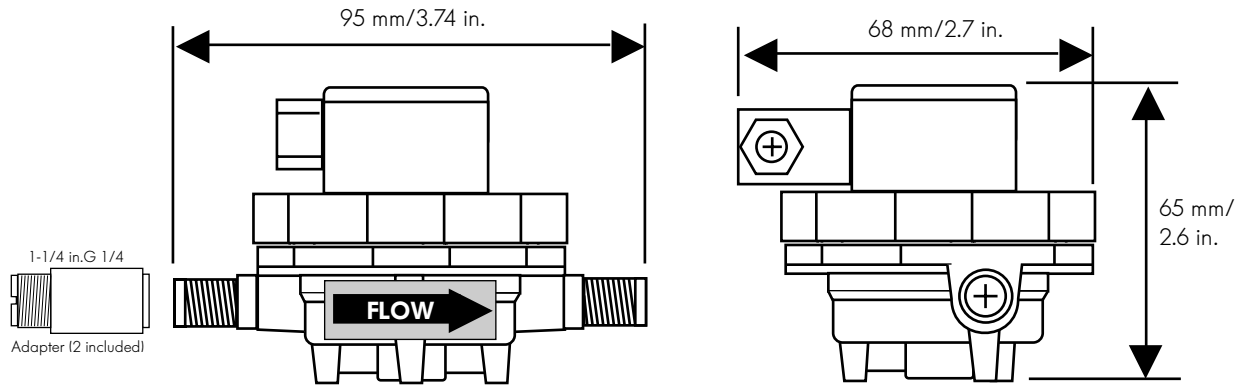

# Installation

- The sensor may be installed in any position, although horizontal flow is recommended with the top of the sensor pointing upward. If the sensor is not installed horizontally, the linearity error may be greater in the lower part of the sensor's measurement range. Mounting tabs are provided for surface mounting using #8 or M4 self-tapping screws (customer supplied). See drawings below for mounting tab hole pattern specifications.
- Install sensor with the arrow pointing in the direction of flow.
- Always maximize distance between the sensor and pump source. Never install immediately downstream of valves, fittings etc. For optimum performance, a straight flow run of at least 100 to 150 mm (4 to 6 in.) should be provided before and after the sensor.

- Two pipe fitting adapters (included) convert the sensor's G1/4 in. straight threads to 1/4 in. NPT pipe threads for use with common pipe fittings. Hand tighten only! Apply 1-2 turns of sealant to all threaded connections to prevent leaks.

### WARNING!

Only **hand tighten** the fitting adapters to prevent over tightening while installing mating pipe connectors. Sensor damage will occur if the ports are over tightened.

### Installation Hints

- Avoid vibrations and shocks
- Avoid solids in the fluid
- Install a filter or line strainer upstream to protect sensor

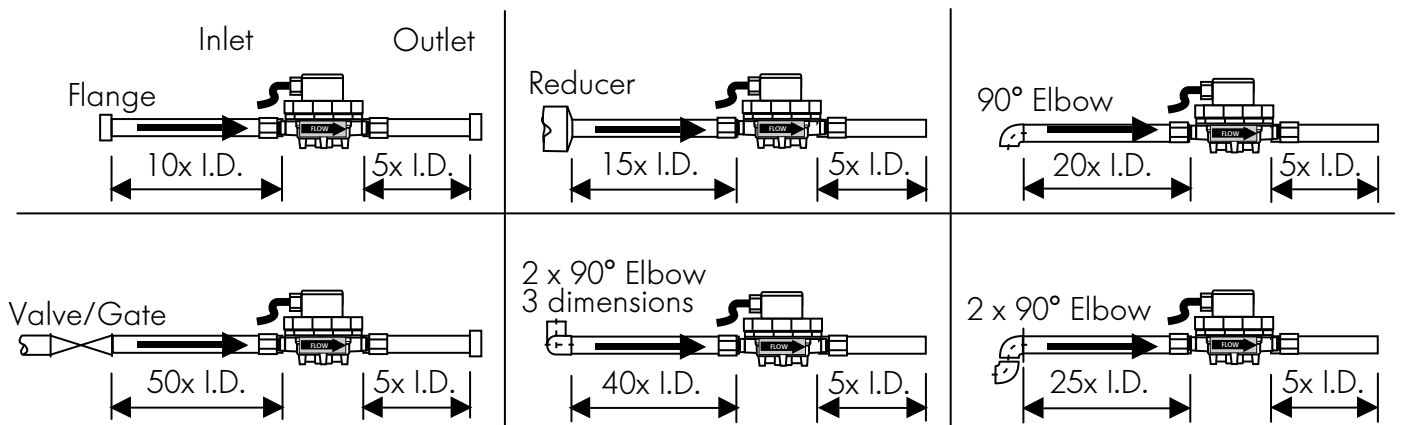
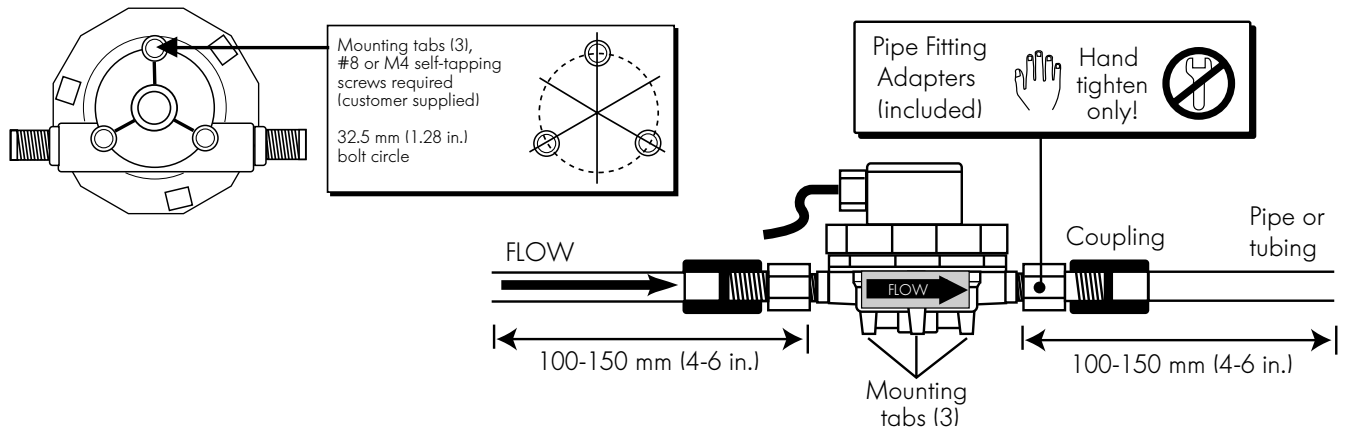

## Wiring

### +GF+ SIGNET

- Use 2-conductor shielded cable for cable extensions up to 300 m (1000 ft).
- Cable shield must be maintained through cable splice.
- +GF+ SIGNET Intelk-Pro, use 2536 input card setting
- Refer to your instrument manual for specific wiring details.

### Other Brands

- Pull-up resistor required (10 k $\Omega$  recommended).
- Use 2-conductor shielded cable for cable extensions up to 300 m (1000 ft).
- Cable shield must be maintained through cable splice.

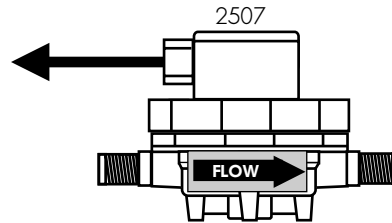
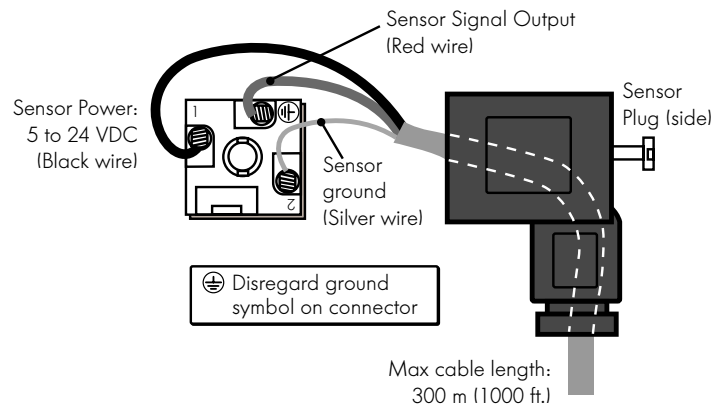

## Technical Data

### General

Flow Range:

-2V sensor:	0 to 2800 mL/m (0.0 to 0.740 U.S. gpm)
-3V sensor:	250 to 4250 mL/m (0.066 to 1.123 U.S. gpm)
-4V sensor:	250 to 6000 mL/m (0.066 to 1.585 U.S. gpm)
-6V sensor:	1500 to 12000 mL/m (0.396 to 3.170 U.S. gpm)

Linearity (see table below):

Sensor model	Flow insert	1.5% Linearity Range	
		mL/m	U.S. gpm
3-2507.100-2V	2 mm	0 to 2800	0 to 0.740
3-2507.100-3V	3 mm	250 to 4250	0.066 to 1.123
3-2507.100-4V	4 mm	250 to 6000	0.066 to 1.585
3-2507.100-6V	none	1500 to 12000	0.396 to 3.170
Sensor model	Flow insert	0.25% Repeatability Range	
		mL/m	U.S. gpm
3-2507.100-2V	2 mm	500 to 2800	0.106 to 0.740
3-2507.100-3V	3 mm	750 to 4250	0.198 to 1.123
3-2507.100-4V	4 mm	1250 to 6000	0.330 to 1.585
3-2507.100-6V	none	3000 to 12000	0.702 to 3.170

*Test medium: Water @ 20°C (68°F)*

Sensor Model	Flow Insert	K-FACTORS		
		PULSES PER U.S. GAL	PULSES PER LITER	PULSES PER mL
-2V	2 mm	5685	1502	1.502
-3V	3 mm	3308	874	0.874
-4V	4 mm	2316	612	0.612
-6V	None	1249	330	0.330

Repeatability:	$\pm 0.25\%$ of full range
Viscosity range:	0.2 to 20.0 centistokes
Pipe connections:	G 1/4 in. ports, 1/4 in. NPT (male) pipe adapters (2 included)
Cable length:	8 m (25 ft.), can splice up to 300 m (1000 ft.) max.
Cable type:	2-conductor shielded twisted-pair (22 AWG) (SIGNET 5523-0222)

### Wetted Materials

- Housing: PVDF
- Flow insert: PTFE
- Quad ring seal: Viton®
- Rotor: PVDF
- Pipe thread adapters: PVDF
- Suitable for clean fluids only

### Signal

Power:	5 to 24 VDC @ 10 mA max from +GF+ SIGNET instrument or external supply
Output type:	Open-collector transistor, 10 mA max. sink

### Max. pressure/temperature:

- 5.5 bar @ -30°C (80 psi @ -22°F)
- 5.5 bar @ 24°C (80 psi @ 75°F)
- 3 bar @ 120°C (45 psi @ 248°F)

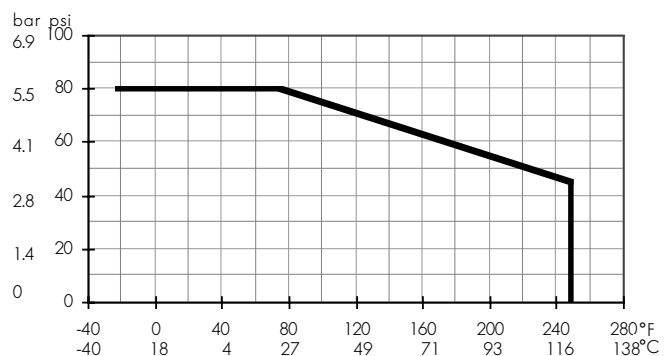

## Ordering Information

Mfr. Part No.	Code	Description
3-2507.100-2V	198 801 732	Mini-Flow Sensor, 2mm insert
3-2507.100-3V	198 801 733	Mini-Flow Sensor, 3mm insert
3-2507.100-4V	198 801 734	Mini-Flow Sensor, 4mm insert
3-2507.100-6V	159 000 264	Mini-Flow Sensor, 6mm inlet, no insert

## Accessories

Mfr. Part No.	Code	Description
3-2507.080-2	159 000 254	Rotor, 2507
3-2507.080-3	159 000 255	Quad Ring, 2507
3-2507.080-5	159 000 256	DIN Connector, 2507
3-2507.081-2	198 801 502	2 mm Insert
3-2507.081-3	198 801 503	3 mm Insert
3-2507.081-4	198 801 558	4 mm Insert
5523-0222	159 000 392	Cable, per foot

## Engineering Specifications

- The sensor shall operate with a power input of 4.5 to 24 VDC @ 13 mA maximum.
- The sensor shall provide an output signal via an open-collector transistor sinking a maximum of 10 mA.
- Output shall be via a twisted pair, foil-shielded cable with drain wire.  
Supplied cable shall be at least 7.6 m (25 ft) long, with a maximum allowable length of 300 m (1000 ft).
- Measurement repeatability shall be  $\pm 0.25\%$  of full range.
- The sensor shall be available in versions that accommodate nominal flow rates from:
  - 0 to 2800 ml/min (0 to 0.749 gpm)
  - 250 to 4250 ml/min (0.07 to 1.12 gpm)
  - 250 to 6000 ml/min (0.07 to 1.589 gpm)
  - 1500 to 12000 ml/min (0.4 to 3.2 gpm)
- The sensor body and rotor shall be made of polyvinylidene fluoride (PVDF) that shall accommodate up to 80 psi @ -30°C (-22°F) and 45 psi @ 120°C (248°F).
- The sensor body shall be constructed to allow easy access for inspecting and cleaning internal mechanical parts without exposing electronic components.
- The sensor shall provide 0.25 in. NPT male fittings for attachment to rigid pipe or tubing.
- The flow sensor shall be +GF+ SIGNET, Model 2507 Mini Flow.