

+GF+ SIGNET 2507 Mini Flow Sensor

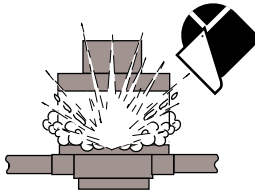

SAFETY INSTRUCTIONS

1. Do not service sensor when line is pressurized.
2. Confirm chemical compatibility before use.
3. Do not exceed maximum temperature/pressure specifications.
4. Do not install/service without following mounting procedure.
5. Wear safety goggles and faceshield during installation/service.
6. Do not alter product construction.
7. Failure to follow safety instructions could result in severe personal injury.

1. Description

The +GF+ SIGNET 2507 Mini Flow Sensor contains a free-running rotor which is driven by the fluid flow. Within the given measurement range, the rotational speed of the rotor is proportional to the fluid flow rate. Permanent magnets built into the rotor actuate an electronic switch in the top of the sensor generating a square-wave output signal proportional to flow rate. Both opaque and transparent fluids can be measured from 0.2 to 20.0 centistokes.

The 2507 is compatible with all current +GF+ SIGNET flow instrumentation (except +GF+ SIGNET 5100 Battery Powered Flow Monitor).

Wetted sensor parts are constructed of PVDF and Viton®, making the sensor suitable for use with most process fluids, including most acids, bases, light oils, and solvents.



WARNING!

Polar organic solvents (i.e., ketones and chlorinated hydrocarbons) and aromatic hydrocarbons are not compatible with this sensor.

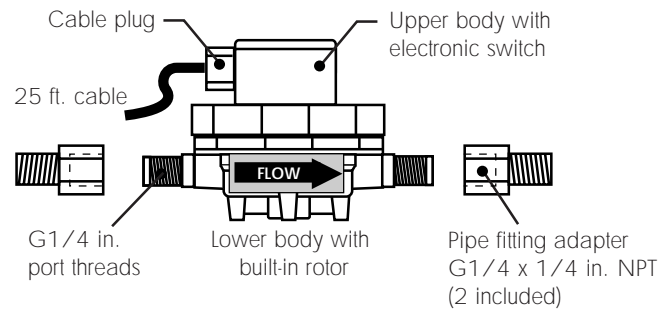

2. Installation

- The sensor may be installed in any position, although horizontal flow is recommended with the top of the sensor pointing upward. If the sensor is not installed horizontally, the linearity error may be greater in the lower part of the sensor's measurement range. Mounting tabs are provided for surface mounting using #8 or M4 self-tapping screws (customer supplied). See section 8 for mounting tab hole pattern specifications.
- Install sensor with the arrow pointing in the direction of flow.
- Always maximize distance between the sensor and pump source. Never install immediately downstream of valves, fittings etc. For optimum performance, a straight flow run of at least 100 to 150 mm (4 to 6 in.) should be provided before and after the sensor.
- Two pipe fitting adapters (included) convert the sensor's G1/4 in. straight threads to 1/4 in. NPT pipe threads for use with common pipe fittings. **Hand tighten only!** Apply 1-2 turns of sealing tape to all threaded connections to prevent leaks.

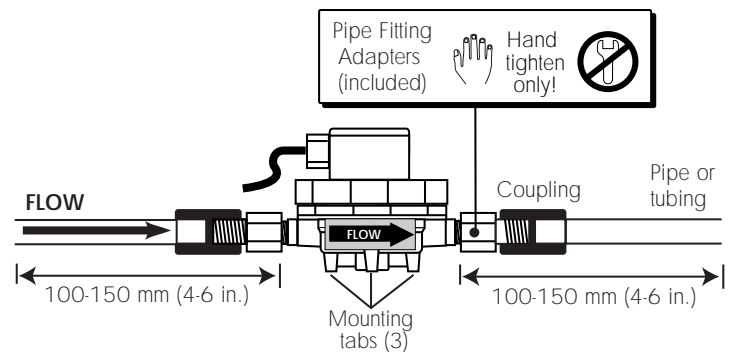

Compatible pipe/tubing connections (customer supplied):



Female SxT coupling

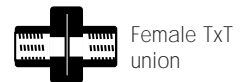

Female TxT union



Female TxT coupling



Hose adapter



WARNING!

Use an adjustable wrench to prevent the fitting adapters from overtightening while installing mating pipe connectors. Sensor damage will occur if the ports are overtightened.

Installation Hints

- Avoid vibrations and shocks
- Avoid solids in the fluid
- Install a filter or line strainer upstream to protect sensor

3. Wiring Details

3.1 Cable Extensions

The standard 25 foot sensor cable can be extended to 300 m (1000 ft.) using 2-conductor **shielded twisted-pair** cable.

- Always maintain cable shield through cable splice.
- For splice-free cable replacement up to 300 m (1000 ft.), refer to the sensor plug connection diagram (right) for connection details.

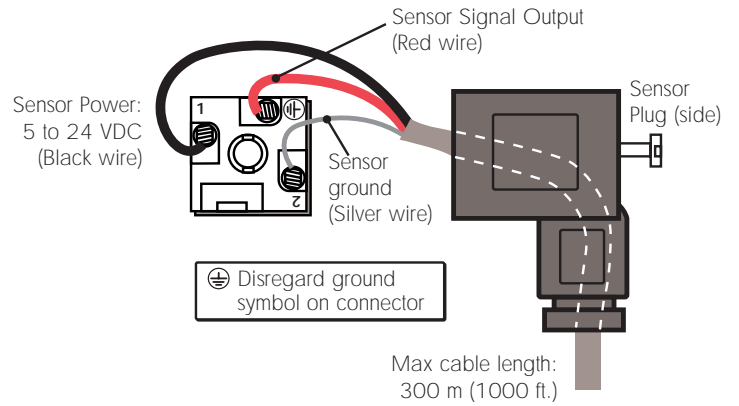

3.2 Instrument Connections

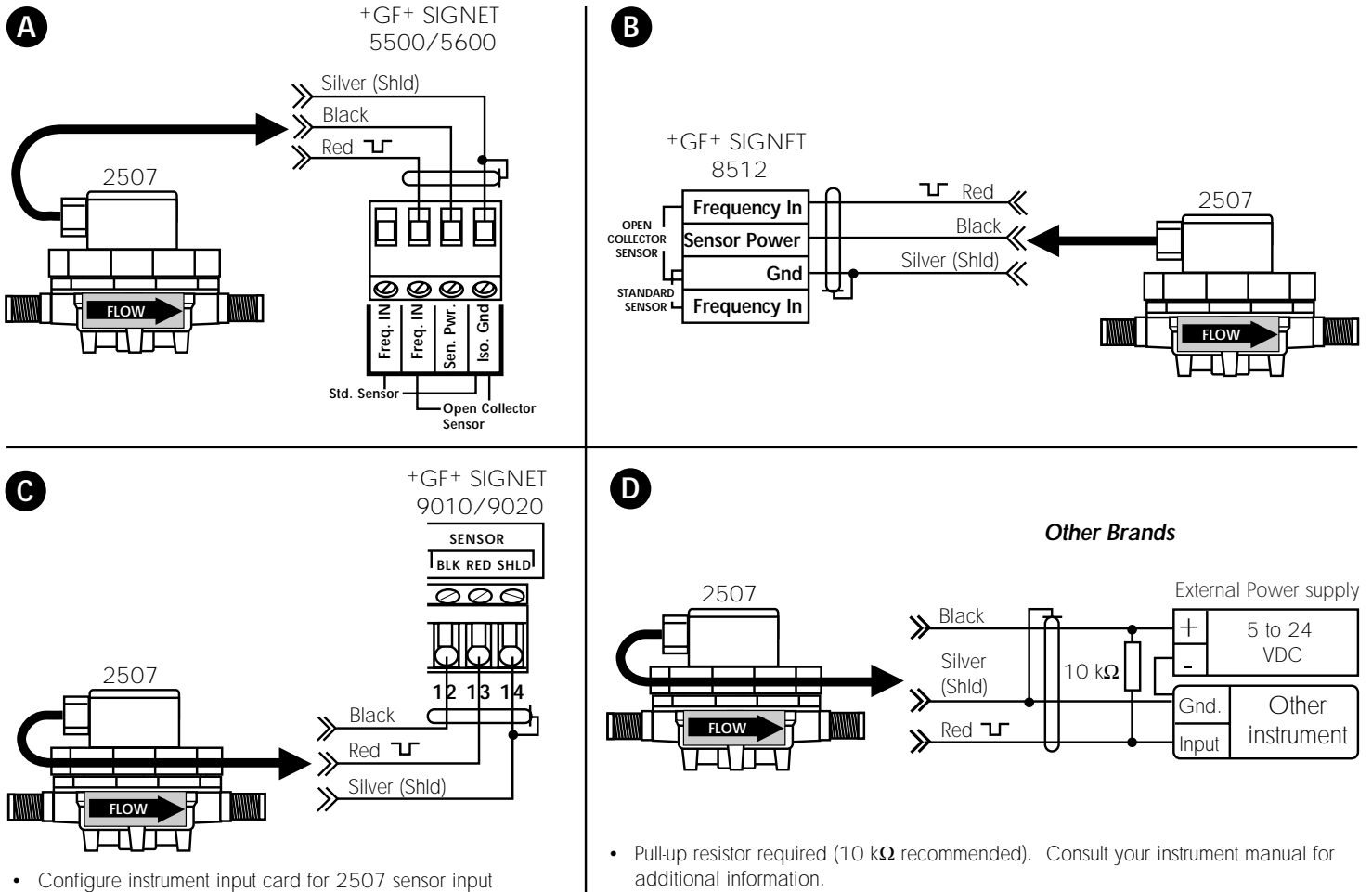

4. Calibration

Calibration of the connected instrument is accomplished by entering the appropriate sensor K-Factor. The K-Factors listed below represent the number of pulses the sensor will generate for each measured engineering unit. They are listed in U.S. gallons, liters, and mL by sensor model.

Sensor Model	Flow Insert	K-FACTORS		
		PULSES PER U.S. GAL	PULSES PER LITER	PULSES PER mL
3-2507.100-2V	2 mm	5685	1502	1.502
3-2507.100-3V	3 mm	3308	874	0.874
3-2507.100-4V	4 mm	2316	612	0.612
3-2507.100-6V	None	1249	330	0.330

5. Replacement Parts

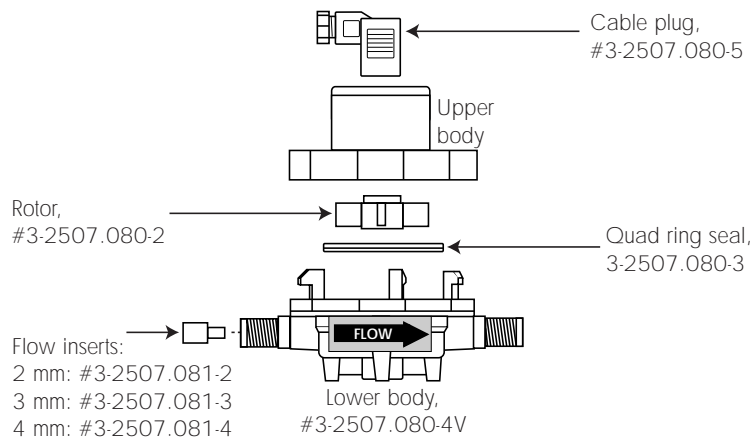

6. Replacing The Flow Insert

Sensor range can be modified by changing the flow insert. The sensor must be removed from service and disassembled prior to installing the new flow insert. See section 8 specifications for flow range data.

Flow Insert Replacement Procedure:

1. Depressurize system and remove sensor.
2. Rotate the upper sensor body clockwise approximately 6 mm (1/4 in.) until it releases from the lower half, then lift off.
3. Remove rotor and quad ring seal from lower body.
4. Gently push the flow insert outward using a small screwdriver.
5. Gently install the new flow insert (small diameter inward) with the eraser end of a pencil. Apply light pressure until insert seats against the step in the lower body. Do not force!
6. Install rotor into lower body. Gently spin rotor with finger and check for free rotation. If rotor hits flow insert, remove rotor and gently push insert back until free rotor rotation is established. Use a rounded object like a pen or pencil body to adjust flow insert depth.
7. Install rotor, quad ring, and upper body. **Hand tighten only!** Do not overtighten upper body or the lower body assembly tabs will break.
8. Reprogram instrument with new K-Factor, see calibration section 4.

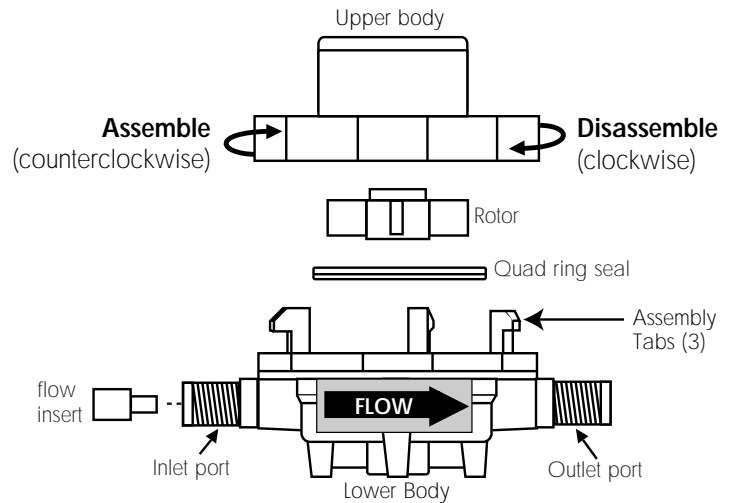

WARNING!

Do not use tools of any kind on the sensor body or port connections. Hand tighten only! Excessive force will damage sensor.

7. Troubleshooting

Condition	Recommendation
Erratic or missing sensor signal	<p>A) Verify ALL sensor cable and instrument connections (section 3).</p> <p>B) Verify proper sensor installation (section 2).</p> <p>C) Remove power from instrument and disconnect sensor inputs. Power up instrument and check across it's Black (Sensor Power) and Silver (Shld/Gnd.) terminals with a digital voltage meter for 5 VDC. If 5 VDC is not present, the instrument requires service or may be misconfigured. +GF+ SIGNET Intelk-Pro controllers require input card configuration for 2507 sensor inputs, see instrument manual.</p>
Perform steps A - E If sensor problems persist, contact your local +GF+ SIGNET dealer.	<p>D) Verify the 2507 paddlewheel is spinning freely by blowing into the flow chamber. If the paddlewheel doesn't spin freely, the following conditions may exist:</p> <ul style="list-style-type: none"> • The sensor may be dirty or clogged. Disassembly and clean with hot tap water and soft brush (see section 6). • The rotor may be hitting the flow insert. Disassembly and adjust flow insert depth (see section 6). <p>E) Test sensor with flow system active and sensor powered. Use an oscilloscope to check the sensor input signal across the instrument's Red (Signal IN) and Silver (Shld/Gnd) terminals. A square wave signal should appear at these terminals. If no signal is present replace sensor.</p>

8. Specifications

General

Flow Range:

- -2V sensor: 0 to 2800 mL/m (0.0 to 0.740 U.S. Gpm)
- -3V sensor: 250 to 4250 mL/m (0.066 to 1.123 U.S. Gpm)
- -4V sensor: 250 to 6000 mL/m (0.066 to 1.585 U.S. Gpm)
- -6V sensor: 1500 to 12000 mL/m (0.396 to 3.170 U.S. Gpm)

Linearity (see table below):

Sensor model	Flow Insert	1.5% Linearity Range	
		mL/m	U.S. Gpm
3-2507.100-2V	2 mm	0 to 2800	0 to 0.740
3-2507.100-3V	3 mm	250 to 4250	0.066 to 1.123
3-2507.100-4V	4 mm	250 to 6000	0.066 to 1.585
3-2507.100-6V	none	1500 to 12000	0.396 to 3.170
Sensor model	Flow Insert	0.5% Linearity Range	
		mL/m	U.S. Gpm
3-2507.100-2V	2 mm	500 to 2800	0.106 to 0.740
3-2507.100-3V	3 mm	750 to 4250	0.198 to 1.123
3-2507.100-4V	4 mm	1250 to 6000	0.330 to 1.585
3-2507.100-6V	none	3000 to 12000	0.792 to 3.170

Test medium: Water @ 20 °C (68 °F)

Repeatability: ±0.25% of full range

Viscosity range: 0.2 to 20.0 centistokes

Pipe connections: G1/4 in. ports, 1/4 in. NPT (male) pipe adapters (2 included)

Cable length: 8 m (25 ft.), can splice up to 300 m (1000 ft.) max

Cable type: 2-conductor shielded twisted-pair, 22 AWG

Weight: 115 g (4 oz.)

Wetted Materials

- Housing: PVDF
- Flow insert: PTFE
- Quad ring seal: Viton®
- Rotor: PVDF
- Pipe thread adapters: PVDF

Electrical

- Power: 5 to 24 VDC @ 10 mA max from +GF+ SIGNET instrument or external supply
- Output type: Open-collector transistor, 10 mA max sink

Dimensions:

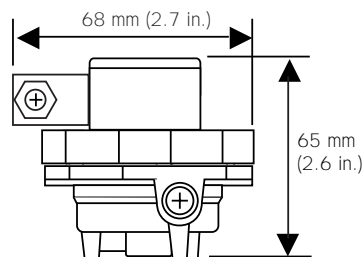
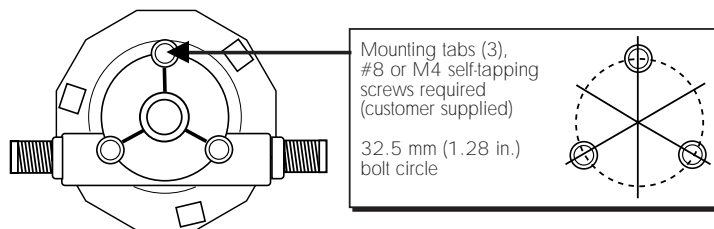
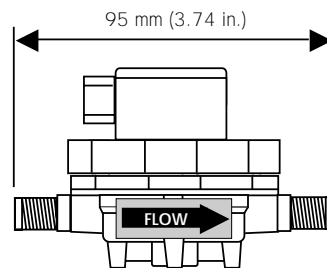

Max pressure/temperature:

- 5.5 bar @ -30 °C (80 psi @ -22 °F)
- 5.5 bar @ 24 °C (80 psi @ 75 °F)
- 3 bar @ 120 °C (45 psi @ 248 °F)

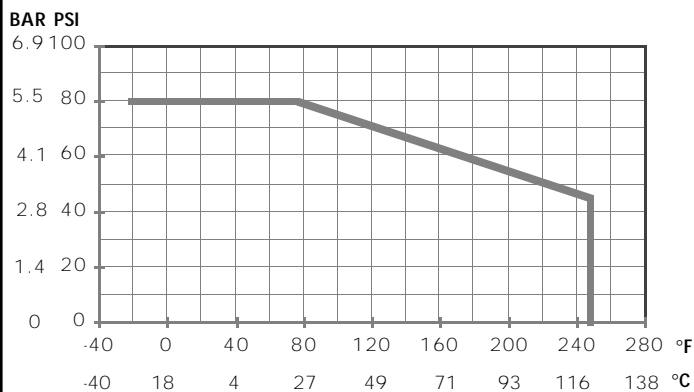

WARNING!

Do not use flow sensor in applications where pressures/temperatures exceed the values on this curve.

+GF+ SIGNET

Signet Scientific Company, 3401 Aerojet Avenue, El Monte, CA 91731-2882 U.S.A. • Tel. (626) 571-2770 • Fax (626) 573-2057
For Worldwide Sales and Service, visit our website: gfsignet.com • Or call (in the U.S.): (800) 854-4090

GEORGE FISCHER +GF+ Piping Systems
3-2507.090 (1-10/99)

© Scientific Company 1999



Printed in U.S.A. on recycled paper
+GF+ SIGNET 2507 Mini Flow Sensor