

Warranty, Service & Repair

To register your product with the manufacturer, fill out the enclosed warranty card and return it immediately to:

Flowline Inc.
10500 Humbolt Street
Los Alamitos, CA 90720.

If for some reason your product must be returned for factory service, contact Flowline Inc. to receive a Material Return Authorization number (MRA) first, providing the following information:

1. Part Number, Serial Number
2. Name and telephone number of someone who can answer technical questions related to the product and its application.
3. Return Shipping Address
4. Brief Description of the Symptom
5. Brief Description of the Application

Once you have received a Material Return Authorization number, ship the product prepaid in its original packing to:

Flowline Factory Service
MRA _____
10500 Humbolt Street
Los Alamitos, CA 90720

To avoid delays in processing your repair, write the MRA on the shipping label. Please include the information about the malfunction with your product. This information enables our service technicians to process your repair order as quickly as possible.

FLOWLINE®

Tuning Fork LZ10/LZ11 Series Owner's Manual



Version 2.0A

© 1999 FLOWLINE Inc.

All rights reserved.

Manual # LZ900001

5/99

WARRANTY

Flowline warrants to the original purchaser of its products that such products will be free from defects in material and workmanship under normal use and service for a period which is equal to the shorter of one year from the date of purchase of such products or two years from the date of manufacture of such products.

This warranty covers only those components of the products which are non-moving and not subject to normal wear. Moreover, products which are modified or altered, and electrical cables which are cut to length during installation are not covered by this warranty.

Flowline's obligation under this warranty is solely and exclusively limited to the repair or replacement, at Flowline's option, of the products (or components thereof) which Flowline's examination proves to its satisfaction to be defective. FLOWLINE SHALL HAVE NO OBLIGATION FOR CONSEQUENTIAL DAMAGES TO PERSONAL OR REAL PROPERTY, OR FOR INJURY TO ANY PERSON.

This warranty does not apply to products which have been subject to electrical or chemical damage due to improper use, accident, negligence, abuse or misuse. Abuse shall be assumed when indicated by electrical damage to relays, reed switches or other components. The warranty does not apply to products which are damaged during shipment back to Flowline's factory or designated service center or are returned without the original casing on the products. Moreover, this warranty becomes immediately null and void if anyone other than service personnel authorized by Flowline attempts to repair the defective products.

Products which are thought to be defective must be shipped prepaid and insured to Flowline's factory or a designated service center (the identity and address of which will be provided upon request) within 30 days of the discovery of the defect. Such defective products must be accompanied by proof of the date of purchase.

Flowline further reserves the right to unilaterally waive this warranty and to dispose of any product returned to Flowline where:

- a. There is evidence of a potentially hazardous material present with product.
- b. The product has remained unclaimed at Flowline for longer than 30 days after dutifully requesting disposition of the product.

THERE ARE NO WARRANTIES WHICH EXTEND BEYOND THE DESCRIPTION ON THE FACE OF THIS WARRANTY. This warranty and the obligations and liabilities of Flowline under it are exclusive and instead of, and the original purchaser hereby waives, all other remedies, warranties, guarantees or liabilities, express or implied. EXCLUDED FROM THIS WARRANTY IS THE IMPLIED WARRANTY OF FITNESS OF THE PRODUCTS FOR A PARTICULAR PURPOSE OR USE AND THE IMPLIED WARRANTY OF MERCHANTABILITY OF THE PRODUCTS.

This warranty may not be extended, altered or varied except by a written instrument signed by a duly-authorized officer of Flowline, Inc.

SPECIFICATIONS

Step One

Accuracy: ± 1 mm in water
Repeatability: $\pm .5$ mm in water
Frequency: 400 Hz (dry)
Supply voltage: 12-36 VDC
Consumption: Relay: 25 mA
 FET: 8 mA (dry)
 19 mA (wet)
Relay rating: 60 VDC/VAC @ 1A
FET rating: 36 VDC @ 100 mA
Switch output: Selectable NO or NC states
Temperature range: F: -40° to 194°
 C: -40° to 90°
Pressure range: 150 psi (10 bar) @ 25°C ., derated @ 1.667
 psi (.113 bar) per $^{\circ}\text{C}$. above 25°C .
Sensor material: PP/Ryton® (40% glass)
Sensor rating: NEMA 6 / IP68
Mounting threads: 3/4" NPT (3/4" G)
Mounting gasket: Viton (3/4") metric only
Cable type: 8 ft. (2.5 m), 4-wire (relay) or 3-wire (FET),
 22 gauge with ground, shield & PP jacket
CE compliance: EN 50082-2 immunity
 EN 55011 emission

Tuning Fork Switch	
	LZ1 - 14
Sensor	
0 - General	
1 - Sludge	
Mounting Thread	
0 - 3/4" NPT	
2 - 3/4" G	
Switch Output	
2 - FET, N-Channel	
3 - FET, P-Channel	
5 - Relay	

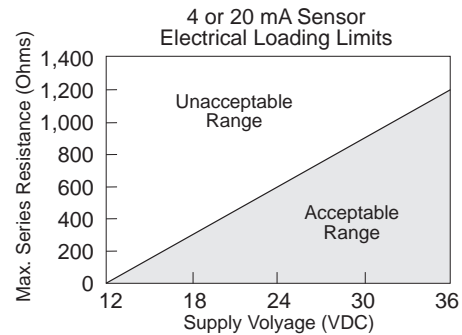
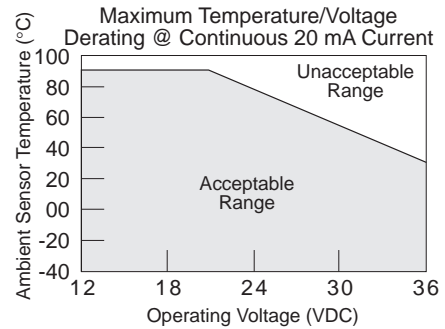
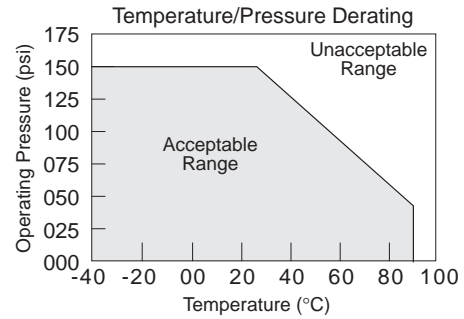

Dimensions:

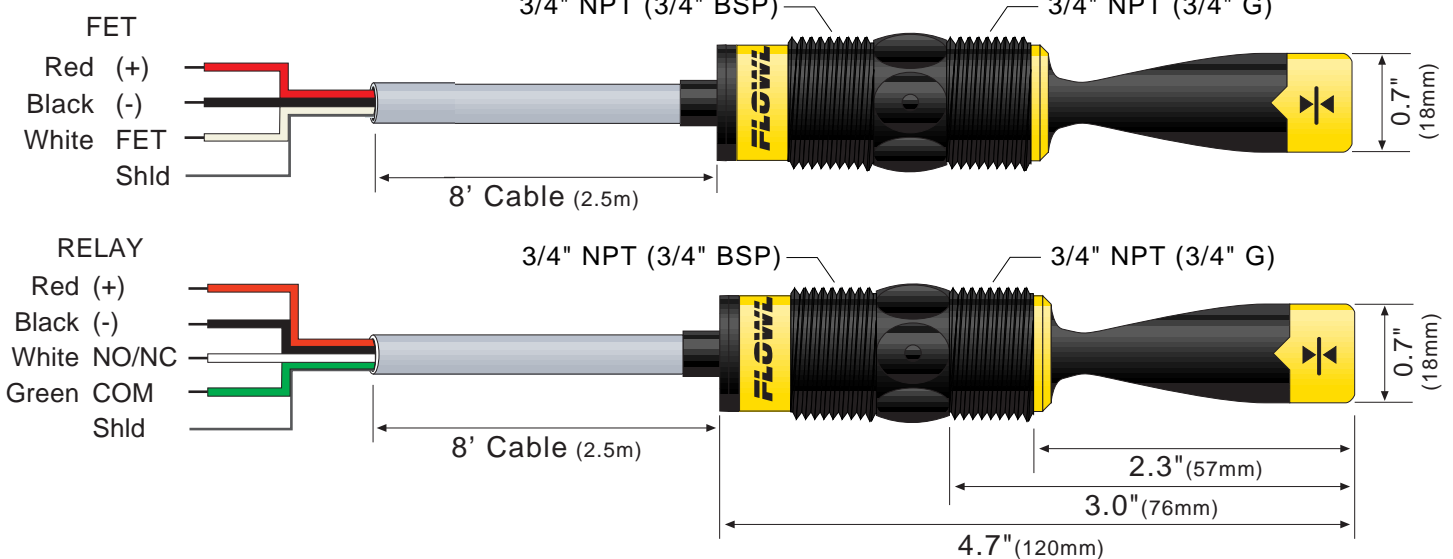

SAFETY PRECAUTIONS

Step Two

About this Manual:

PLEASE READ THE ENTIRE MANUAL PRIOR TO INSTALLING OR USING THIS PRODUCT. This manual includes information on two different models of Tuning Fork sensors from FLOWLINE, all in the LZ10 and LZ11 series. Please refer to the part number located on the sensor label to verify the exact model which you have purchased.

User's Responsibility for Safety:

FLOWLINE manufactures a wide range of liquid level sensors and technologies. While each of these sensors is designed to operate in a wide variety of applications, it is the user's responsibility to select a sensor model that is appropriate for the application, install it properly, perform tests of the installed system, and maintain all components. The failure to do so could result in property damage or serious injury.

Proper Installation and Handling:

Because this is an electrically operated device, only properly-trained staff should install and/or repair this product. Use a proper sealant with all installations. Note: *Always install the 3/4" Viton gasket with the LZ1_-142_. The G threaded version of the Tuning Fork will not seal unless the gasket is installed properly.* Never overtighten the transmitter within the fitting. Always check for leaks prior to system start-up.

Material Compatibility:

The LZ10/LZ11 series sensor is available in one wetted material version. The bodies of the LZ1_-14__ are made of PP (Polypropylene) with the forks made of Ryton (40% glass filled). Make sure that the model which you have selected is compatible with the application liquids. To determine the chemical compatibility between the sensor and its application liquids, refer to the Compass Corrosion Guide, available from Compass Publications (619-589-9636).

Temperature and Pressure:

The LZ10/LZ11 series sensor is designed for use in application temperatures up to 90 °C, and for use at pressures up to 150 psi @ 25 °C., derated @ 1.667 psi per °C. above 25 °C.

Wiring and Electrical:

The supply voltage used to power the LZ10/LZ11 series sensor should never exceed a maximum of 36 volts DC. Electrical wiring of the sensor should be performed in accordance with all applicable national, state, and local codes.

Flammable, Explosive and Hazardous Applications:

The LZ10/LZ11 series sensor should not be used within flammable or explosive applications. In hazardous applications, use redundant measurement and control points, each having a different sensing technology.

WARNING

Do not squeeze the forks together. Doing so could damage or break the sensor and void the warranty.

Always install the 3/4" Viton gasket with the LZ1_-142_. The G threaded version of the Tuning Fork will not seal unless the gasket is installed properly.

INTRODUCTION

Step Three

Technology:

The Tuning Fork switch vibrates at a nominal frequency of 400 Hz. As the switch becomes immersed in a liquid or slurry, a corresponding frequency shift occurs. When the measured frequency shift reaches the set point value, the switch changes state indicating the presence of a liquid or slurry medium.

The LZ10-14__ is designed for detecting the change between air and liquid mediums. The LZ11-14__ is designed for detecting the change between a liquid medium and a suspension.

Initialization Sequence:

When powering up the LZ10/LZ11, the start-up procedure requires the switch to cycle through a wet condition for 1/2 second in order to determine an initial resonance.

INSTALLATION

Step Four

Through Wall Installation:

FLOWLINE's LZ10/LZ11 series sensors may be installed through the top, side or bottom of a tank wall. The sensor has male 3/4" NPT threads on either side of a 15/16" wrench flat. This enables the user to select the sensor's mounting orientation, installed outside of the tank in, or inside of the tank out.

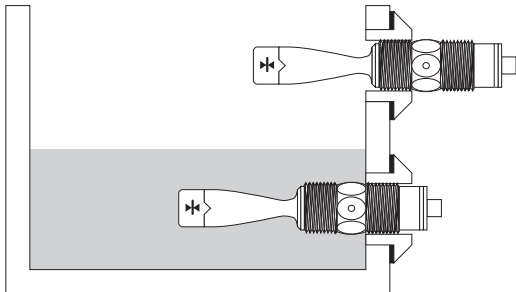

Smart Trak™ Installation:

FLOWLINE's Smart Trak LM10 series mounting system is an in-tank fitting which enables users to install up to four FLOWLINE sensors of any technology, to any depth, along the entire length of a track. Smart Trak may be installed through the top wall of any tank using a standard 2" NPT tank adapter. If no tank top is available, FLOWLINE's side mount bracket, LM50-1001 enables Smart Trak to be installed directly to the side wall of a tank.

Switch Pak™ Installation:

FLOWLINE's Switch Pak LM45 series mounting system is an in-tank fitting which enables users to install one FLOWLINE sensor, of any technology to a specified depth. The FLOWLINE sensor may be installed onto the 3/4" NPT adapter at the end of the Switch Pak. Switch Pak may be installed through the top wall of any tank using a standard 2" NPT tank adapter.

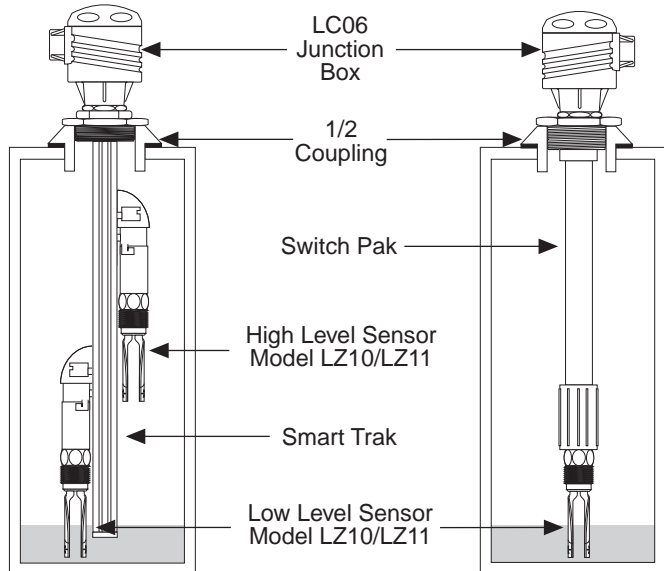

⚠ WARNING ⚠

Do not squeeze the forks together. Doing so could damage or break the sensor and void the warranty.

Always install the 3/4" Viton gasket with the LZ1_-142_. The G threaded version of the Tuning Fork will not seal unless the gasket is installed properly.

ORIENTATION

Step Five

When installing the LZ10/LZ11, make sure that the forks do not touch the walls of the tank. Consider possible build up along the inner tank wall.

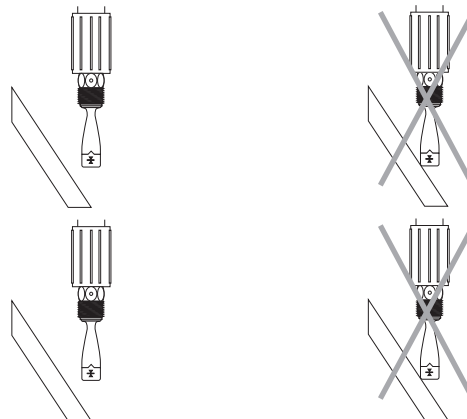

Higher viscosity liquids may build up inside of a flange and cause the LZ10/LZ11 to fail wet.

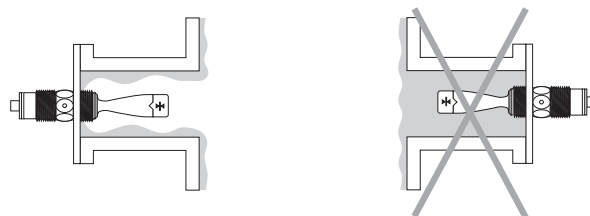

If installing the tuning fork within a pipe, make sure the forks allow the liquid to flow between them and not around them.



When installing the LZ10/LZ11 horizontally, make sure that the forks orientation is vertical and not horizontal.

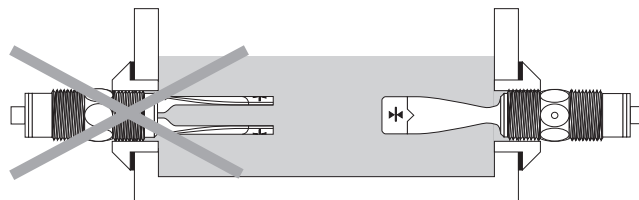

ELECTRICAL

Step Six

Supply Voltage: The supply voltage to the LZ10/LZ11 series sensor should never exceed a maximum of 36 VDC. FLOWLINE controllers have a built-in 13.5 VDC power supply which provides power to all of FLOWLINE's electrically powered sensors. Alternative controllers and power supplies, with a minimum output of 12 VDC up to a maximum output of 36 VDC, may also be used with the LZ10/LZ11 series sensor.

Cable Length: Determine the length of cable required between the LZ10/LZ11 series sensor and its point of termination. Allow enough slack to ensure the easy installation, removal and/or maintenance of the sensor. The cable length may be extended up to a maximum of 1000 feet, using a well-insulated, 20 gauge shielded wire.

Wire Stripping: Using a 10 gauge wire stripper, carefully remove the outer layer of insulation from the last 1-1/4" of the sensor's cable. Unwrap and discard the exposed foil shield from around the signal wires, leaving the drain wire attached if desired. With a 20 gauge wire stripper, remove the last 1/4" of the colored insulation from the signal wires.

Signal Outputs (Current sensing): The standard method used by FLOWLINE controllers; this method uses only two wires (Red and Black). The sensor draws 8 mA when it is dry, and 19 mA when wet. NC/NO status must be set by the controller. The White wire is not used.

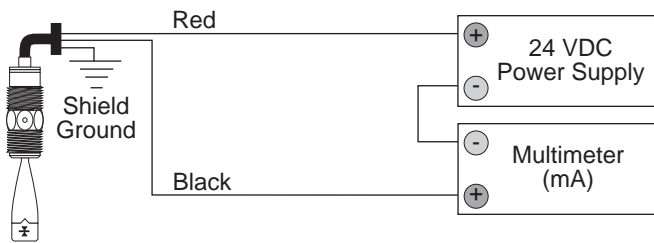

Signal Outputs (FET switching): Allows the sensor to switch a small DC load on or off directly, using all three wires. Model LZ1_-14_2 is an NPN type switch, which toggles the negative side of the load; model LZ1_-14_3 is a PNP type switch for applications where the switch must be on the positive side of the load. In both FET models, the NO/NC status is set by the polarity of the voltage feeding the Red and Black wires, and the White wire connects to the load.

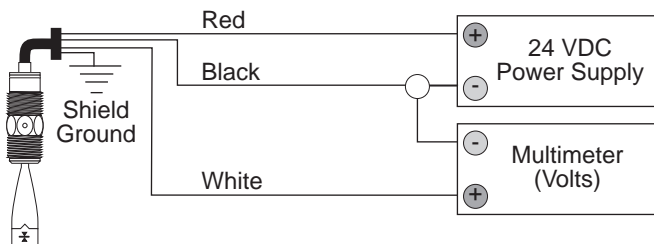

Signal Output (Relay switching): Allows the sensor to switch a small load on or off directly, using an internal 1A relay (60 VAC/60 VDC). Only models LZ1_-14_5 uses the relay and features 4 wires (red, black, white and green) and a shield wire. The NO/NC status is set by the polarity of the voltage feeding the red and black wires. The green wire is the common for the relay and the white wire is the NO or NC, depending on the polarity of red and black.



WIRING

Step Seven

Models LZ1_-140_2, LZ1_-14_3 & LZ1_-14_5 Only Wiring to a FLOWLINE Controller

LC10 Series Controller (4 or 20 mA signal output)

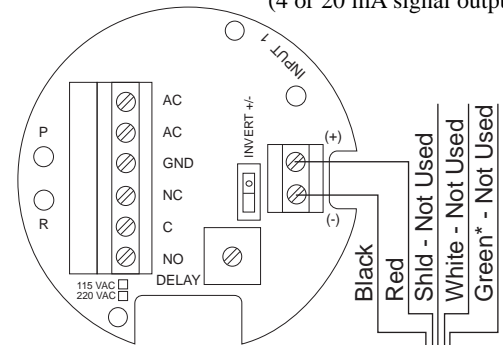

LC40 Series Controller (4 or 20 mA signal output)

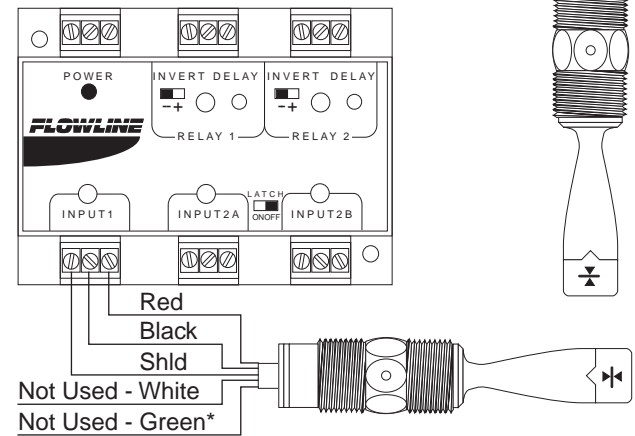

* The Green wire is for model LZ1_-1405 only

WIRING

Step Eight

Models LZ1_-14_2 & LZ1_-14_3 Only

Wiring direct to a load, NC operation (FET signal output)

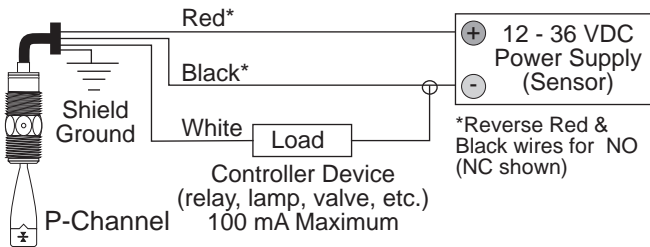
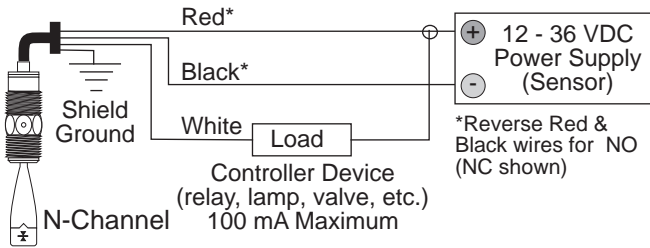

Wiring direct to load, Normally Open operation:

LZ1_-14_2 and LZ1_-14_3 (FET outputs only):

This is the same as the wiring for Normally Closed operation, except the polarity of the Red and Black connections to the sensor is reversed. The other connections remain the same; the sensor and device power supplies remain tied in the same polarity as before. This method will turn the load on when the sensor is wet.

Models LZ1_-14_5 Only

Wiring direct to a load, NO operation (Relay signal output)

Relay Output *Reverse Red & Black wires for NC (NO shown)

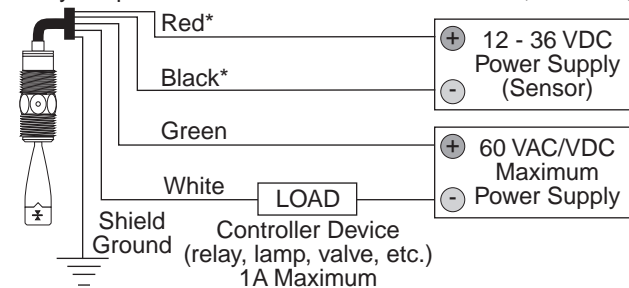

Wiring direct to load, Normally Closed operation:

LZ1_-14_5 (Relay outputs only):

This is the same as the wiring for Normally Open operation, except the polarity of the Red and Black connections to the sensor is reversed. The other connections remain the same; the sensor and device power supplies remain tied in the same polarity as before. This method will turn the load on when the sensor is dry.

MAINTENANCE

Step Nine

General:

The LZ10/LZ11 series sensor itself requires no periodic maintenance except cleaning as required. It is the responsibility of the user to determine the appropriate maintenance schedule, based on the specific characteristics of the application liquids.

Cleaning Procedure:

- 1. Power:** Make Sure that all power to the sensor, controller and/or power supply is completely disconnected.
- 2. Sensor Removal:** In all through-wall installations, make sure that the tank is drained well below the sensor prior to removal. Carefully, remove the sensor from the installation.
- 3. Cleaning the Sensor:** Use a soft bristle brush and mild detergent, carefully wash the LZ10/LZ11 series sensor. Do not use harsh abrasives such as steel wool or sandpaper, which might damage the surface sensor. Do not use incompatible solvents which may damage the sensor's Polypropylene plastic body.
- 4. Sensor Installation:** Follow the appropriate steps of installation as outlined in the installation section of this manual.

Testing the installation:

- 1. Power:** Turn on power to the controller and/or power supply.
- 2. Immersing the switch:** Immerse the sensing tip in its application liquid, by filling the tank up to the switches point of actuation. An alternate method of immersing the switch during preliminary testing is to hold a cup filled with application liquid up to the switch's tip.
- 3. Test:** With the switch being fluctuated between wet and dry states, the switch indicator light in the controller should turn on and off. If the controller doesn't have an input indicator, use a voltmeter or ammeter to ensure that the switch produces the correct signal.
- 4. Point of actuation:** Observe the point at which the rising or falling fluid level causes the switch to change state, and adjust the installation of the switch if necessary.