

Warranty, Service & Repair

To register your product with the manufacturer, fill out the enclosed warranty card and return it immediately to:

Flowline Inc.
10500 Humbolt Street
Los Alamitos, CA 90720.

If for some reason your product must be returned for factory service, contact Flowline Inc. to receive a Material Return Authorization number (MRA) first, providing the following information:

1. Part Number, Serial Number
2. Name and telephone number of someone who can answer technical questions related to the product and its application.
3. Return Shipping Address
4. Brief Description of the Symptom
5. Brief Description of the Application

Once you have received a Material Return Authorization number, ship the product prepaid in its original packing to:

Flowline Factory Service
MRA _____
10500 Humbolt Street
Los Alamitos, CA 90720

To avoid delays in processing your repair, write the MRA on the shipping label. Please include the information about the malfunction with your product. This information enables our service technicians to process your repair order as quickly as possible.

FLOWLINE®

Flow/No-Flow Compact Relay Controller LC30 Series Owner's Manual



Version 3.0A
© 1999 FLOWLINE Inc.
All rights reserved.
Manual # LC900008

7/99

WARRANTY

Flowline warrants to the original purchaser of its products that such products will be free from defects in material and workmanship under normal use and service for a period which is equal to the shorter of one year from the date of purchase of such products or two years from the date of manufacture of such products.

This warranty covers only those components of the products which are non-moving and not subject to normal wear. Moreover, products which are modified or altered, and electrical cables which are cut to length during installation are not covered by this warranty.

Flowline's obligation under this warranty is solely and exclusively limited to the repair or replacement, at Flowline's option, of the products (or components thereof) which Flowline's examination proves to its satisfaction to be defective. FLOWLINE SHALL HAVE NO OBLIGATION FOR CONSEQUENTIAL DAMAGES TO PERSONAL OR REAL PROPERTY, OR FOR INJURY TO ANY PERSON.

This warranty does not apply to products which have been subject to electrical or chemical damage due to improper use, accident, negligence, abuse or misuse. Abuse shall be assumed when indicated by electrical damage to relays, reed switches or other components. The warranty does not apply to products which are damaged during shipment back to Flowline's factory or designated service center or are returned without the original casing on the products. Moreover, this warranty becomes immediately null and void if anyone other than service personnel authorized by Flowline attempts to repair the defective products.

Products which are thought to be defective must be shipped prepaid and insured to Flowline's factory or a designated service center (the identity and address of which will be provided upon request) within 30 days of the discovery of the defect. Such defective products must be accompanied by proof of the date of purchase.

Flowline further reserves the right to unilaterally waive this warranty and to dispose of any product returned to Flowline where:

- a. There is evidence of a potentially hazardous material present with product.
- b. The product has remained unclaimed at Flowline for longer than 30 days after dutifully requesting disposition of the product.

THERE ARE NO WARRANTIES WHICH EXTEND BEYOND THE DESCRIPTION ON THE FACE OF THIS WARRANTY. This warranty and the obligations and liabilities of Flowline under it are exclusive and instead of, and the original purchaser hereby waives, all other remedies, warranties, guarantees or liabilities, express or implied. EXCLUDED FROM THIS WARRANTY IS THE IMPLIED WARRANTY OF FITNESS OF THE PRODUCTS FOR A PARTICULAR PURPOSE OR USE AND THE IMPLIED WARRANTY OF MERCHANTABILITY OF THE PRODUCTS.

This warranty may not be extended, altered or varied except by a written instrument signed by a duly-authorized officer of Flowline, Inc.

SPECIFICATIONS

Step One

Supply voltage: 120 / 240 VAC, 50 - 60 Hz.
 Consumption: 5 watts
 Sensor inputs: (1) sensor
 Sensor supply: 13.5 VDC @ 100 mA
 Configuration: LC30-1001: Flow/no-flow alarm
 LC30-1002: Flow/no-flow alarm w/ Strobe

Relay type: (1) SPDT
 Relay rating: 250 VAC, 10A, 1/2 hp.
 Relay mode: Selectable, NO or NC
 Time delay: 0 to 60 seconds
 LED indication: Sensor, relay & power status
 Fail safety: Power fail-safe
 Temperature range: F: -40° to 158°
 C: -40° to 70°

Enclosure rating: NEMA 4X (IP65)
 Enclosure material: Polypropylene (U.L. 94 VO)
 Enclosure rotation: 300° swivel base
 Conduit connection: 1/2" NPT
 Certificate number: LR 79326-3
 CE compliance: EN 50082-2 immunity
 EN 55011 emission
 EN 61010-1 Safety

Flash Alarm (Included with LC30-1002)
 Flash type: Xenon tube
 Flash frequency: 1 per second
 Strobe life: 10M cycles
 Supply voltage: 120 VAC (240 VAC), 50 - 60 Hz.
 Consumption: 5 Watts
 Material: Polycarbonate
 Enclosure rating: NEMA 4X / IP65
 Color: Amber

Internal Controller Logic

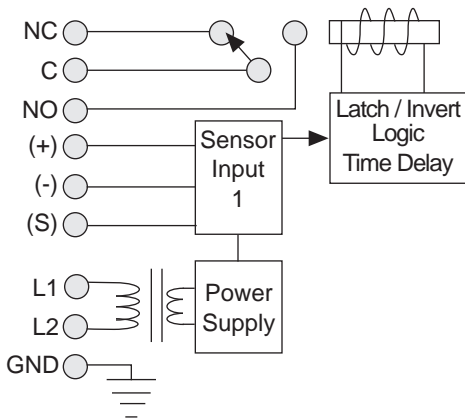

Remote Relay Controller

LC30-10
Thread Size
 0 - 3/4" NPT
 5 - 3/4" G
Output
 1 - 1 Relay
 2 - 1 Relay w/ Strobe Alert

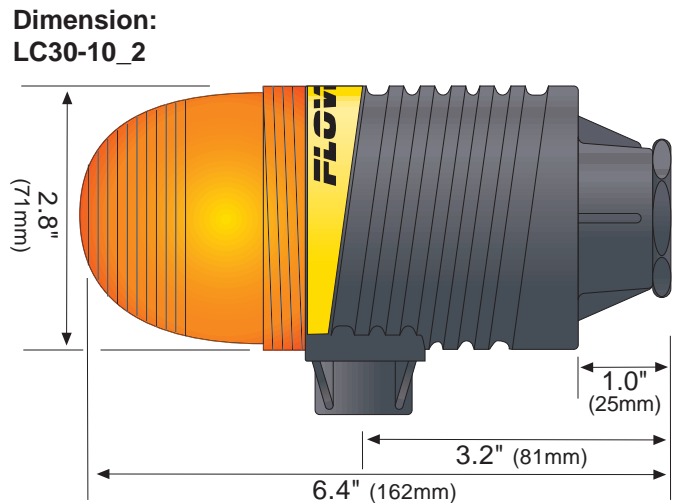
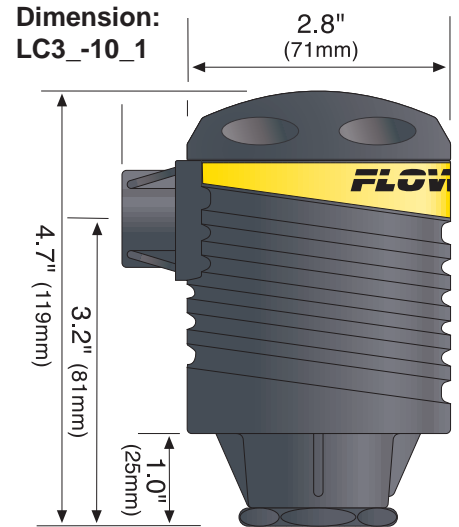

LC30 Faceplate

LC30-10 Label

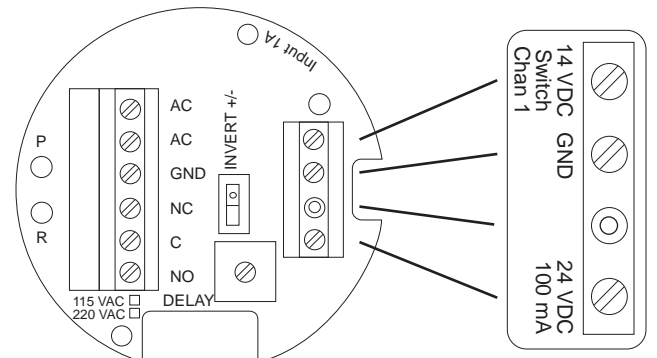

SAFETY PRECAUTIONS

Step Two

About This Manual:

PLEASE READ THE ENTIRE MANUAL PRIOR TO INSTALLING OR USING THIS PRODUCT. This manual includes information on two different models of Compact Relay Controllers from Flowline: LC30-10_1 and LC30-10_2. The LC30 is a single-input controller with an optional Strobe Alert™ on the -10_2 model. Many aspects of installation and use are similar between the three models.

User's Responsibility for Safety:

FLOWLINE manufactures several models of controller, with different mounting and switching configurations. It is the user's responsibility to select a controller model that is appropriate for the application, install it properly, perform tests of the installed system, and maintain all components.

Electrical Shock Hazard:

It is possible to contact components on the controller that carry high voltage, causing serious injury or death. All power to the controller and the relay circuit(s) it controls should be turned OFF prior to working on the controller. If it is necessary to make adjustments during powered operation, use extreme caution and use only insulated tools. Making adjustments to powered controllers is not recommended. Wiring should be performed by qualified personnel in accordance with all applicable national, state and local electrical codes.

Flammable or Explosive Applications:

Sensor mount controllers (LC30 series) should not be used with explosive or flammable liquids, which require an intrinsically safe rating such as the Flowline LC90 series. If you are unsure of the suitability of a controller for your installation, consult your Flowline representative for further information.

Install In a Dry Location:

The LC30 series controller housing is liquid-resistant and made of Polypropylene (PP). When installed properly, the controller is not designed to be immersed. It should be mounted in such a way that it does not normally come into contact with fluid. Refer to an industry reference to ensure that compounds that may splash onto the controller housing will not damage it. Such damage is not covered by the warranty.

Relay Contact Rating:

The relay is rated for a 10 amp resistive load. Many loads (such as a motor during start-up or incandescent lights) are reactive and may have an inrush current characteristic that may be 10 to 20 times their steady-state load rating. The use of a contact protection circuit may be necessary for your installation if the 10 amp rating does not provide an ample margin for such inrush currents.

INTRODUCTION

Step Three

Make a Fail-Safe System:

Design a fail-safe system that accommodates the possibility of relay or power failure. If power is cut off to the controller, it will de-energize the relay. Make sure that the de-energized state of the relay is the safe state in your process. For example, if controller power is lost, a pump filling a tank will turn off if it is connected to the Normally Open side of the relay.

While the internal relay is reliable, over the course of time relay failure is possible in two modes: under a heavy load the contacts may be "welded" or stuck into the energized position, or corrosion may build up on a contact so that it will not complete the circuit when it should. In critical applications, redundant backup systems and alarms must be used in addition to the primary system. Such backup systems should use different sensor technologies where possible.

While this manual offers some examples and suggestions to help explain the operation of FLOWLINE products, such examples are for information only and are not intended as a complete guide to installing any specific system.

Sensor-mount controllers:

The LC30 is a cost-effective, modular liquid level controller whose body incorporates a female 3/4" NPT (3/4" BSP) fitting, allowing it to be mounted directly onto any Flowline sensor or Switch Pak™ or any 3/4" connection. Simply provide its required AC power and a controlled device such as a valve, pump, or alarm that can be switched by the controller's relay in response to the sensor input.

Features of the LC30 Single Input Controller:

The LC30 Controller is designed to receive a signal from a single flow switch. It turns its internal relay On or Off (as set by the invert switch) in response to the presence of flow or no-flow, and changes the relay status back again when the sensor reverses. The LC30 may be used with any FLOWLINE N-channel flow or level switch. The relay is a single pole, double throw type; the controlled device can be connected to either the normally open or normally closed side of the relay. A time delay from 0 to 60 seconds can be set before the relay responds to the sensor input.

Typical applications for the LC30 are flow or no-flow switch/alarm operations (activating an alarm at no-flow).

GUIDE TO CONTROLS

Step Four

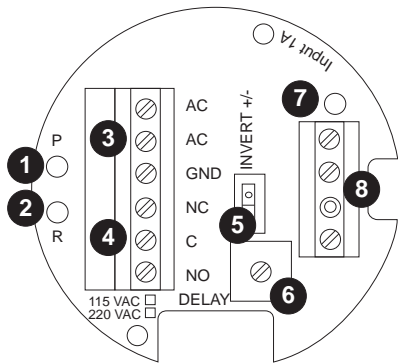

1. **Power indicator:** This green LED lights when AC power is ON.
2. **Relay indicator:** This red LED will light whenever the controller energizes the relay, in response to the proper condition at the sensor input(s) and after the time delay.
3. **AC Power terminals:** Connection of 120 VAC power to the controller. The setting may be changed to 240 VAC if desired. This requires changing internal jumpers; this is covered in the Installation section of the manual. Polarity (neutral and hot) does not matter.
4. **Relay terminals (NC, C, NO):** Connect the device you wish to control (pump, alarm etc.) to these terminals: supply to the COM terminal, and the device to the NO or NC terminal as required. The switched device should be a noninductive load of not more than 10 amps; for reactive loads the current must be derated or protection circuits used. When the red LED is ON and the relay is in the energized state, the NO terminal will be closed and the NC terminal will be open.
5. **Invert switch:** This DIP switch reverses the logic of the relay control in response to the sensor(s): conditions that used to energize the relay will make it turn off and vice versa.
6. **Time Delay:** After the input(s) change(s) state, this control sets a delay from 0.15 to 60 seconds before the relay will respond.
7. **Input 1:** This amber LED will light immediately whenever the appropriate sensor attached to the terminals detects liquid, and will turn off when it is dry.
8. **Input terminals:** Connect the wiring from the sensors to these terminals. Note the polarity: (+) is a 13.5 VDC, 100 mA power supply (to be connected to the red wire of a Flowline sensor), and (-) is the return path from the sensor (to be connected to the black wire of a Flowline sensor). (S) is the FET (NPN) signal input to be connected to the white wire.

INSTALLATION

Step Five

3/4" NPT Mounting Thread:

Installation of the compact relay controller takes advantage of the 3/4" NPT thread located on its base. This makes the controller fully compatible with any of Flowline's level switches or Smart Trak™ or Switch Pak™ mounting systems.

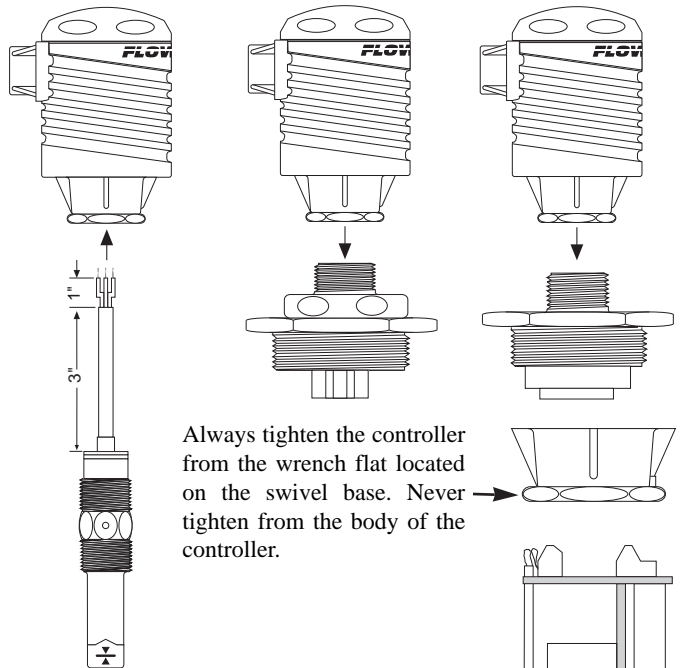

Switch Cable:

When installing a Flowline level switch, adjust the cable away from the printed circuit boards in the controller body. Avoid breaking the seal between the top of the level switch and the plastic coated cable.

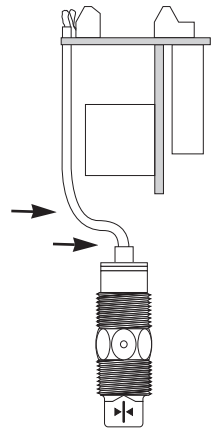

Connecting switches to input terminals:

Please note a difference between FLOWLINE flow switches. All flow switches (models FT10-__2 and GT10-__2) will be wired with the Red wire to the (+) terminal, the Black wire to the (-) terminal and the White wire to the (S) terminal. FLOWLINE flow switches (models FT10-__3, GT10-__3, FT10-__5 and GT10-__5) will not operate with the flow switch controller. See the illustration below to indicate wiring for your switch. **Note:** the Shield wire will be used only for long cable runs or where excessive electrical noise is present.

Flow Switch Normally Closed

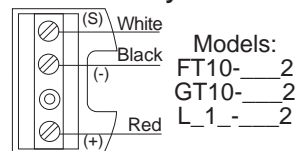

Flow Switch Normally Open

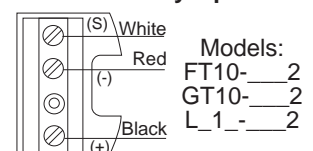

INSTALLATION

Step Six

VAC Power Input Wiring:

Observe the labeling on the LC30. *Note: Polarity does not matter with the AC input terminal.*

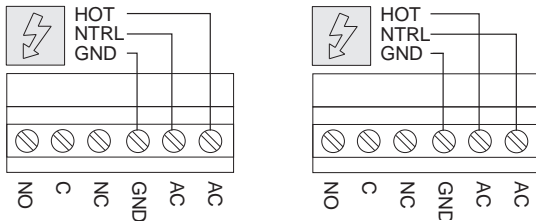

Relay Input Wiring

The relay is a single pole, double throw type rated at 250 Volts AC, 10 Amps, 1/2 Hp. The two terminal NO and NC (normally open and normally closed) will be used in different applications. Remember that the "normal" state is when the relay coil is de-energized and the Red relay LED is Off / de-energized.

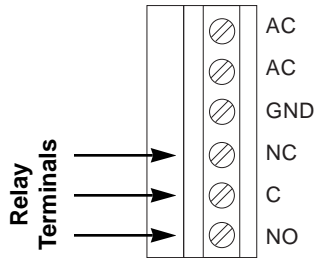

Strobe Alert Output

With the Strobe Alert wired NC, it can be used as a high or low level alarm, depending on the setting for the invert switch. Strobe can also be wired NO.

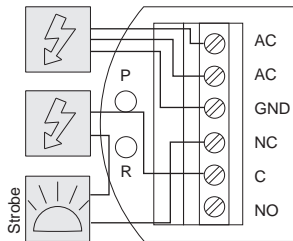

Changing from 120 to 240 VAC

1. Remove the two screws from the top of the printed circuit board (PCB) and gently slide the PCB from the housing. Use caution when removing the PCB.
2. Located jumpers JWA, JWB and JWC on the PCB.
3. To change to 240 VAC, remove jumpers from JWB and JWC and place a single jumper across JWA. To change to 120 VAC, remove jumper JWA and place jumpers across JWB and JWC.
4. Gently return PCB into housing and replace the two screws.

120 VAC Configuration

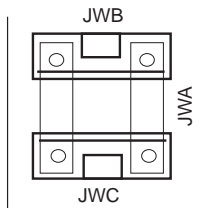

240 VAC Configuration

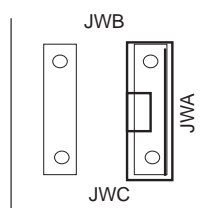

APPLICATION EXAMPLES

Step Seven

Low Flow Alarm

The goal is to indicate when the flow rate falls below a certain point. If it does, an alarm is supposed to sound, alerting the operator of a low flow condition.

If power is accidentally cut to the controller, the sensor's ability to notify the operator of a low flow condition could be lost. The system must alert the operator not only to low flow, but to controller power loss.

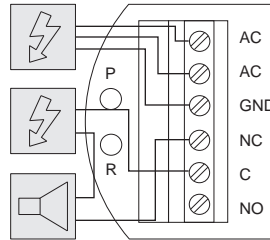

To do this, connect the hot lead of the alarm to the NC side of the relay terminal of the controller. If power is lost, the relay will be de-energized, and the alarm will sound (if there is still power to the alarm circuit itself). The alarm circuit should have a non-interruptible power supply or some other indicator or backup alarm to warn of a power failure in the alarm circuit.

In this application, the normal status is when the sensor is in the flow condition, and the relay will be energized holding the alarm circuit open. Please note that the flow switch can be wired either normally closed or normally open (Step 5). When the switch is wired NC, the input LED will be off and the relay LED will be on. So for this application, Invert should be set to the On position. When the switch is wired NO, the input LED and the relay LED will be on simultaneously. So for this application, Invert should be set to the Off position.

LED Indication:

Use LED's located above the input terminals to indicate whether the switch is in a flow or no-flow state. When the switch is wired NC, Amber indicates no-flow and Off indicates flow. Reversing the polarity (Normally Open), Amber indicates flow and Off indicates no-flow.

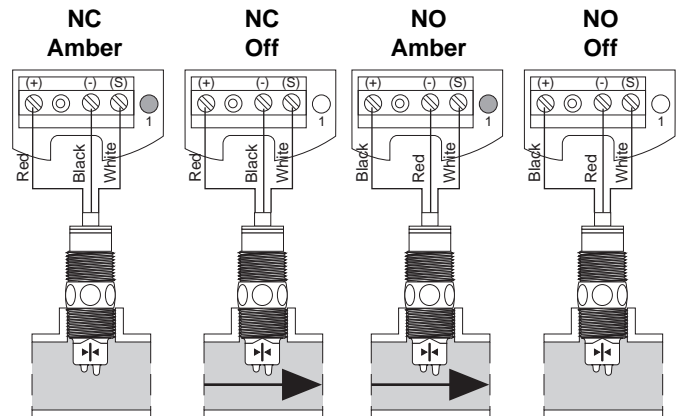

TROUBLESHOOTING

Step Eight

Controller Logic

For all controllers, please use the following guide to understand the operation of the FLOWLINE LC30 controller.

- 1. Power LED:** Make sure the Green power LED is On when power is supplied to the controller.
- 2. Input LED:** For NC switch wiring, the input LED on the controllers will be Amber when the switch reads no-flow and Off when the switch reads flow.
- 3. Invert Operation:** When the input LED turn Off and On, the relay LED will also switch. With invert Off, the relay LED will be On when the input LED is On and Off when the input LED is Off. With invert On, the relay LED will be Off when the input LED is On and On when the input LED is Off.
- 4. Relay Operation:** The relay may be wired either NO or NC. The normal state of the relay is when its LED is Off. With the LED On, the relay is in the energized mode and all terminal connections are reversed.

Step Nine